



THE NEW
XK

OWNER'S HANDBOOK

Publication Part No. **JJM 18 02 30 701**

This handbook forms part of the Owner literature supplied with your vehicle. Right-hand drive and left-hand drive situations are shown in the graphics and where information is specific to a particular country, it is indicated as such.

The **Quick Start** section is designed to rapidly familiarise the driver with the initial set up and also explain some of the unique features. Please take the time to study the operating instructions with your vehicle as soon as you can.

Important

The information contained in this handbook covers all vehicle derivatives and optional equipment . Some of the options will not be fitted to your vehicle unless they formed part of the original vehicle specification. Therefore, some parts of this handbook may not apply to your vehicle. Furthermore, due to printing cycles, it may include descriptions of options before they become generally available.

The information contained in this publication was correct when it went to print. Vehicle design changes may have been made after this handbook was printed. When this occurs a handbook supplement is added to the literature pack. Subsequent updates can be viewed on the Jaguar internet site at **<http://www.ownerinfo.jaguar.com>**.

In the interest of development, the right is reserved to change specifications, design or equipment at any time without notice and without incurring any obligations. This publication, or part thereof, may not be produced nor translated without our approval. Errors and omissions excepted.

©Jaguar Cars Limited 2006.

All rights reserved.

Published by **Jaguar Cars Limited** Technical Communications.

Handbook Contents

Quick Start	7	Vehicle Identification	281
Filling Station Information	27	Technical Specifications	282
Introduction	30	Type Approvals	286
Reporting Safety Defects	33		
Keys and Remote Controls	34	A comprehensive index is located at the	
Locks	41	back of this handbook.	
Alarm	49		
Starting the Engine	50		
Engine Immobiliser	51		
Fuel and Refuelling	52		
Driving Hints	56		
Seats	57		
Steering Wheel	62		
Wipers and Washers	65		
Lighting	69		
Windows and Mirrors	86		
Occupant Protection	91		
Child Safety	103		
Facia and Controls	109		
Instruments	111		
Information Displays	118		
Climate Control	132		
Convenience Features	139		
Convertible Top	147		
Load Carrying	156		
Transmission	157		
Brakes	162		
Stability Control	165		
Parking Aid	167		
Cruise Control	169		
Adaptive Cruise Control (ACC)	172		
Automatic Speed Limiter (ASL)	180		
Audio	182		
Satellite Radio	199		
Telephone	210		
Emergency Equipment	222		
Status After a Collision	223		
Vehicle Recovery	224		
Vehicle Care	227		
Maintenance	232		
Vehicle Battery	242		
Fuses	247		
Wheels and Tires	256		

Quick Start

Quick Start

KEYLESS ENTRY	7
REMOTE HANDSET	7
CENTRAL LOCKING	8
LUGGAGE COMPARTMENT	8
ENGINE START/STOP	9
SEAT ADJUSTMENT	10
STEERING COLUMN - LOCK AND ADJUSTMENT	10
INTERIOR MIRROR	10
WINDOWS/DOOR MIRRORS	11
SEAT POSITION MEMORY	11
SEAT BELTS	12
CENTRE CONSOLE	12
OVERHEAD CONSOLE	13
CLIMATE CONTROL	13
FACIA AND CONTROLS	15
EXTERIOR LAMPS/TRIP COMPUTER	17
WIPERS AND WASHERS	17
WARNING INDICATORS	17
PARKBRAKE	19
TRANSMISSION	19
PARKING ASSIST	20
CRUISE (SPEED) CONTROL	21
ADAPTIVE CRUISE CONTROL (ACC)	21
TOUCH-SCREEN	22
SOUND SETTINGS	22
RADIO OPERATION	23
CD OPERATION	23
NAVIGATION	24
TELEPHONE - BLUETOOTH SYSTEM	25

Filling Station Information

FUEL TYPE	27
HOOD RELEASE	27
UNDERHOOD TOP-UP	28
ULTRA HIGH PERFORMANCE TYRES	28
TIRE PRESSURES	28
TIRE PRESSURE MONITORING SYSTEM	29

Quick Start

KEYLESS ENTRY

Entering the vehicle

The keyless entry system allows access to the vehicle without the need for pressing the unlock button on the remote handset.

When a door handle, or the luggage compartment release button are operated, the vehicle will search for a recognised remote handset signal before unlocking. The handset must be within one metre of the entry point.

The buttons on the remote handset can be used to lock/unlock the vehicle when approaching or leaving the vehicle.

Leaving the vehicle

The vehicle will not automatically lock, or arm the alarm. To leave the vehicle in a secure condition either:



JAG0424G

- press the button on the door handle once (arrowed in the illustration)
- or press the lock button on the remote handset.

REMOTE HANDSET



JAG0423G



- Press once to lock the vehicle and arm the alarm.
- Press twice within three seconds to double lock the vehicle.



- Press once to disarm the alarm, unlock the driver's door, and unlock the luggage compartment.
- Press again to unlock the passenger door.



- Press once to switch the headlamps on for 25 seconds. Press again to switch off.



- Press to deactivate the alarm, and unlock the luggage compartment.

Quick Start



- Press three times in three seconds, or press and hold for longer than three seconds to activate/cancel the panic alarm.

Unlocking mode alternatives

Single stage unlocking will unlock the vehicle with a single press. Two stage unlocking will unlock the driver's door with a single press, and all other doors with a second press.

To change between modes, press and hold the unlock button for four seconds. The direction indicators will flash twice to confirm the change.

CENTRAL LOCKING

Interior door locks

Press either of the interior door release levers to lock both doors and the luggage compartment.

Pull the release lever to unlock the door.

Drive away door locking

This feature can be enabled or disabled via the **Vehicle - Security** settings on the touch-screen.

If enabled, the luggage compartment and doors will automatically lock when the vehicle's forward speed exceeds 7 km/h (5 mph).

LUGGAGE COMPARTMENT

Caution: If the luggage compartment is opened when the driver and passenger doors are locked, ensure that the **Jaguar Smart Key** remains outside the vehicle when it is closed again. If the **Jaguar Smart key** is inadvertently left inside the vehicle (luggage compartment) an audible alarm will sound and the luggage compartment lid will initially re-open. If the lid is subsequently closed without removing the **Jaguar Smart Key** from the luggage compartment, you will be locked out. You should contact your **Jaguar Dealer**.

The luggage compartment is electrically locked in conjunction with the driver's door.

To open the luggage compartment with the vehicle locked:

- press the luggage compartment button on the remote handset.

To open the luggage compartment with the vehicle unlocked:

- press the button on the facia.



JAG0425G

Or:

- press the release button on the luggage compartment lid.

Quick Start

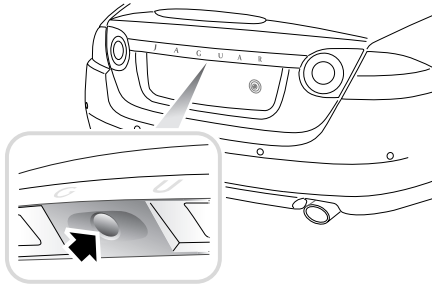

JAG0426G

Emergency key blade access

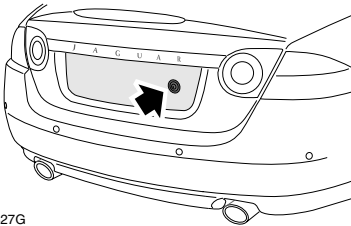

JAG0427G

In the event of a discharged vehicle battery, or other problem opening the luggage compartment, it can be opened by using the key blade in the luggage compartment lock.

Care points

- The registration plate has to be removed to access the luggage compartment lock.
- The vehicle's alarm will sound if the luggage compartment is unlocked with the key blade, whilst the vehicle is locked.

ENGINE START/STOP

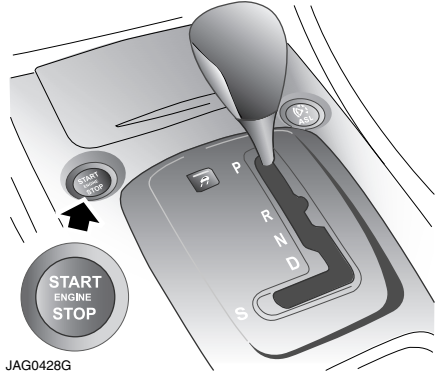

JAG0428G

The engine START/STOP button is only operational when a recognised remote handset is detected within the vehicle.

- A single press of the engine start/stop button will switch on the ignition system.
- Another press of the switch will switch off the ignition system.
- With the gear selector in **P** (Park) and the brake pedal depressed, press the engine START/STOP button to start the engine.
- Press the button to stop the engine and switch off the ignition.

Quick Start

SEAT ADJUSTMENT

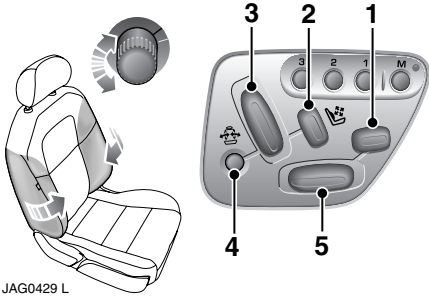

1. Cushion extension switch.
2. Lower backrest and lumbar support switch.
3. Recline adjustment switch.
4. Side bolster adjustment switch. Rotate to adjust the side bolster cushions.
5. Fore/aft, cushion height, and front tilt control switch.

Note: Seat heating adjustment is via the main touch-screen, see page 61.

STEERING COLUMN - LOCK AND ADJUSTMENT

Steering column lock

The steering column has an electronic lock that is automatically disengaged whenever a recognised remote handset is inside the vehicle.

Vehicle recovery

Caution: If the vehicle requires recovery assistance, the remote handset must remain in the vehicle to prevent the steering column lock engaging.

Steering column adjustment

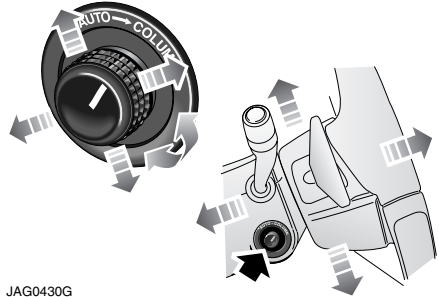

Turn the control on the left-hand side of the steering column to **COLUMN** and move to adjust the height and reach.

Automatic steering column movement

If the control is set to **AUTO**, the position of the steering column will automatically adjust to provide greater clearance for exit and entry when the driver's door is opened for exiting the vehicle.

The steering column will return to the driving position when the driver's door is closed and the engine start button is pressed.

Note: To prevent automatic movement of the steering column, turn the control to the **COLUMN** position.

INTERIOR MIRROR

With the ignition on, the rear view mirror will automatically darken in proportion to the amount of glare detected from a following vehicle's headlamps. This feature is automatically switched off when reverse gear is selected.

Quick Start

WINDOWS/DOOR MIRRORS

Front windows

The windows are fitted with a facility that allows them to be fully opened or closed with a single operation of the switch.

- To open the window, press the respective switch. Press the switch again to stop the window from fully opening.
- To close the window, pull the switch up. Pull the switch again to prevent to window from closing fully.

Door mirror adjustment



JAG0431 L

Press the **L** (left) or **R** (right) button to select the required mirror for adjustment. Use the four-way switch **1** to adjust the position of the selected mirror.

Mirror dip when reversing

The passenger door mirror can be programmed to dip automatically when **R** (reverse) is selected. This will provide a better view along the side of the vehicle to aid parking. The dip position of the mirror can be adjusted via the four-way switch.

This feature can be enabled/disabled via the **Vehicle - Parking** settings on the Touch-screen.

SEAT POSITION MEMORY

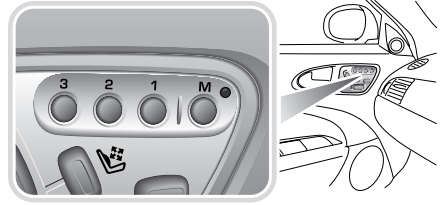

JAG0432L

Driver's seat

Once you have adjusted the driver's seat, steering column, and exterior mirrors, the vehicle can memorise these settings for future use.

1. Push the memory button **M**, the red LED will illuminate for five seconds.
2. Whilst the LED is illuminated, press button **1**, **2**, or **3**, to memorise the current settings.

The LED will extinguish, and a chime will sound to confirm that the settings have been memorised. If the ignition is on, the message centre will display a confirmation message.

Passenger seat

The procedure to memorise a passenger seat position is the same as that for the driver's seat with two exceptions. There will be no chime or message to confirm the settings.

Quick Start

Recalling a seat position

To recall a memorised seat position, simply press and hold button **1**, **2**, or **3**. The button should be held until the seat has stopped moving.

Note: A seat position will only be memorised during the five second period whilst the LED is illuminated.

Any existing settings will be over-written when programming a memory position.

SEAT BELTS



WARNING:

The use of front and rear seat belts is mandatory in most countries.

Using seat belts saves lives.



A warning indicator on the instrument panel will illuminate to warn you that the driver's and/or front passenger's seat belt is unbuckled. This may also be accompanied by a warning chime.

CENTRE CONSOLE

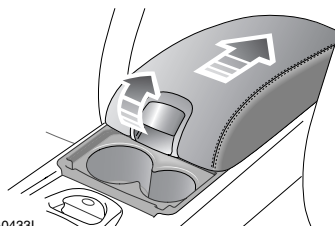

Operate the release button, and slide the armrest rearwards to access the cup holders.

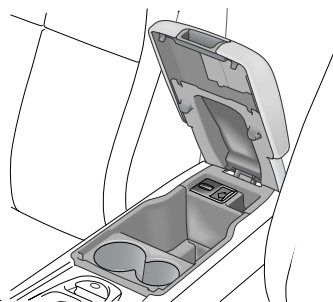

To open the cubby box, operate the release button, and lift the armrest. The armrest will slide back under its own weight to provide better access to the cubby box.

The cubby box has space to store six standard CD cases.

Quick Start

OVERHEAD CONSOLE

Caution: Do not open or close the convertible top whilst the vehicle is in motion. Doing so may damage the convertible top and/or it's operating mechanism.

Do not press the engine stop/start button whilst the convertible top is opening or closing. Doing so will cause the system to lose it's position memory.

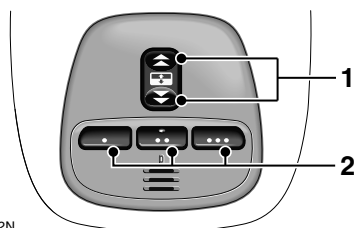

JAG0562N

Convertible top

When operating the convertible top, the switch must be pressed, and held, until the second chime is heard. The second chime confirms that the convertible top has reached the end of it's operation.

- To open press and hold the rear of switch **1**. The windows will fully open.
- To close press and hold the front of switch **1**.

Rear windows

The rear windows can be operated when the convertible top is closed.

- To open press and release the rear of switch **1**. The windows will open fully.
- To close press and hold the front of switch **1**. Release the switch to stop raising the windows.

Garage door opener

For information on the Garage door opener buttons **2**, see page 143.

CLIMATE CONTROL

The following are the primary functions of the climate control system. The climate control system can also be operated via the touch-screen, which gives access to other features, such as heated seats/steering wheel.



JAG0505N

Auto (automatic) mode

Press **AUTO** to turn on and select automatic operation of the climate control system. The system will automatically adjust the heat output, blower speed, air intake, and airflow distribution, to maintain the selected temperature, and reduce misting without the need for constant manual adjustments.

The front and rear screen heating, and timed air recirculation, may be selected in **AUTO** mode. Selecting any other function will cancel **AUTO** operation.

Air conditioning

Air conditioning is an integral part of the climate control system. The air provided is cooled and dehumidified, which helps to prevent misting of the windows.

Air conditioning is automatically switched on and controlled, whenever the system is operating in **AUTO** or **DEF** modes.

Quick Start

External water deposits

The air conditioning system removes moisture from the air and deposits excess water beneath the vehicle. Puddles may form, but this is normal, and no cause for concern.

Recommended mode

Select **AUTO** as the normal operating mode. This will help prevent window misting and odours from the climate control system.

Air recirculation



Press the recirculation button to select. A symbol will appear on the Touch-screen and an LED in the button will illuminate.

To de-select air recirculation, press the recirculation button again, or press the **AUTO** button.

Blower speed

Set the blower speed as required by adjusting the rotary control knob. Any adjustment of the knob will cancel **AUTO** mode.

Temperature selection



Press the red buttons to increase the temperature, and the blue buttons to decrease the temperature.

The passenger and driver temperatures will automatically synchronise if **HI** or **LO** is selected via the driver's side control.

Windshield defrost/demist



Press the **DEF** button to remove frost or heavy misting from the windshield. To de-select defrost mode, press the **DEF** or **AUTO** buttons.

Heated screen and door mirrors



The rear screen heater can be switched on and off in any mode, even when the climate control system is off. It will only operate when the engine is running.

The door mirror heaters are controlled by the rear screen heater button.

System off



Select the ON/OFF button located under the **Climate** tab on the touch-screen.

Quick Start

FACIA AND CONTROLS

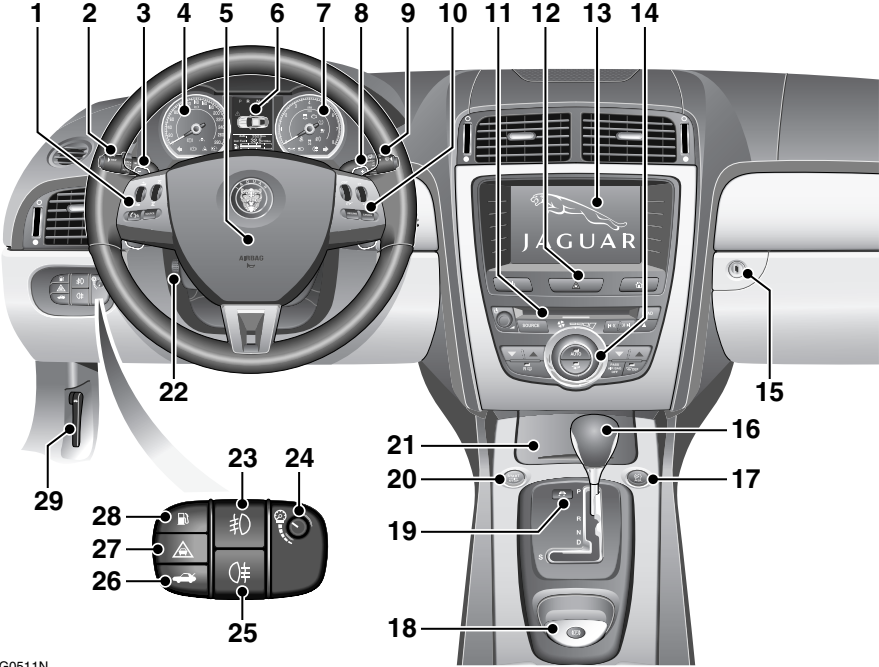

JAG0511N

Quick Start

1. Steering wheel audio switches (64).
2. External light switches (71).
3. Jaguar sequential gear change down paddle (159).
4. Speedometer (111).
5. Driver's horn and air bag (63).
6. Message centre (118).
7. Tachometer (111).
8. Jaguar sequential gear change up paddle (159).
9. Wiper and washer switch (65).
10. Cruise control or adaptive cruise control switches (169).
11. Audio panel (184).
12. Hazard warning switch (76).
13. Touch-screen display (121).
14. Climate control panel (134).
15. Glove box compartment release button (142).
16. Gear selector (157).
17. Automatic speed limiter switch (180).
18. Parkbrake switch (164).
19. Dynamic stability control mode switch (166).
20. Engine Start and Stop switch (50).
21. Ashtray and cigar lighter (140).
22. Steering column adjustment switch (62).
23. Front fog lamp switch (75).
24. Dimmer switch (140).
25. Rear fog lamp switch (75).
26. Luggage compartment release switch (43).
27. Forward alert switch (177).
28. Fuel filler flap release switch (52).
29. Hood release lever (234).

Page numbers (shown in brackets) refer to pages in this handbook that have further relevant information.

Quick Start

EXTERIOR LAMPS/TRIP COMPUTER

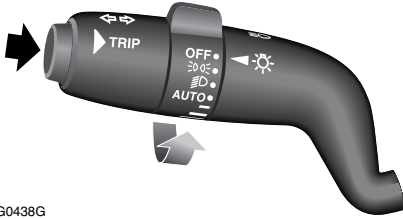

JAG0438G

Move the stalk up or down to activate the direction indicators.

Press the button on the end of the stalk to cycle through the trip computer displays.

Rotate the collar on the stalk to select:

- sidelamps
- headlamps
- autolamps
- headlamp exit delay.

In **AUTO** mode, a sensor monitors the exterior light levels. The sensor will automatically switch the sidelamps and dipped headlamps on and off.

WIPERS AND WASHERS

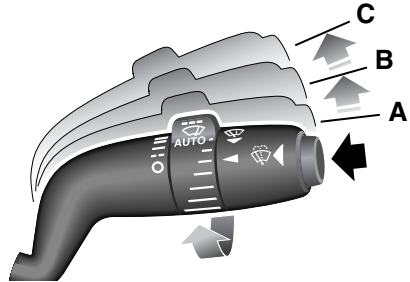

JAG0439G

- A.** Intermittent wipe.
- B.** Slow speed operation.
- C.** High speed operation.

Press the button on the end of the stalk for wash/wipe. Rotate the collar to adjust the time delay for intermittent wipe, or to select **AUTO** for automatic operation of the wipers.

Enabling automatic operation

The wiper stalk must be in position **A** and **AUTO** selected on the collar to enable automatic operation of the wipers.

WARNING INDICATORS



Sidelamps on. (Green).



Headlamp main beam on. (Blue).



Front fog lamps on. (Green).

Quick Start



Rear fog lamp on. (Amber).



Automatic Speed Limiter (ASL) active.
(Green).



Direction indicator. (Green).



Seat belt reminder. (Red).



Forward alert active. (Amber).



Parkbrake on/Low brake fluid (Red)
(USA only)



Anti-Lock braking system fault (Amber)
(USA only)



Parkbrake on/Low brake fluid (Red)
(Canada and Mexico only).



Anti-Lock braking system fault (Amber)
(Canada and Mexico only).



Engine malfunction. (Amber).



Dynamic Stability Control (DSC) off
(normally aspirated engines only).
TracDSC ON.
DSC system fault (Amber).



Adaptive Cruise Control active. (Amber).



Air bag system fault. (Amber).



Adaptive front lighting system fault.
(Amber).



Low tire pressure warning. (Yellow).

Quick Start

Automatic exterior lamps

If **AUTO** (autolamps) has been selected, and the windshield wipers are operated continuously for more than twenty seconds, then the exterior lamps will be switched on automatically.

PARKBRAKE

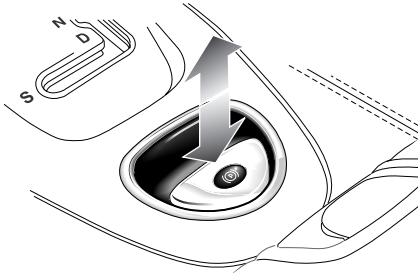

JAG0440L

- Parkbrake will automatically release when the gear selector is moved from **P** (Park) with the footbrake applied.
- Parkbrake can be manually released when the engine is running and the footbrake is applied. Press the parkbrake switch down to release, and pull it up to apply.
- If manually applied whilst in **D** or **R**, the Parkbrake will automatically release when the accelerator is applied.

TRANSMISSION

Gearshift interlock

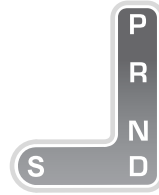

JAG0441G



The ignition must be on, and the footbrake applied, before the gear selector can be moved from **P** (Park) to **R** (Reverse). The selector can be moved into **P** with the ignition off.

Sports mode

When the gear selector is moved from **D** (Drive) to **S** (Sport) automatic changing of the gears is maintained. However, the gear shift points are modified to make full use of the engine's power.

Note: *With the selector lever in **S**, and **DS** displayed in the message centre, the transmission will enter 6th gear less often at higher cruising speeds.*

Fuel consumption will be adversely affected.

Manual operation

Manual changing of the gears via the steering wheel paddles is possible when the gear selector is in either **D** (Drive) or **S** (Sport).

Quick Start

Operation of the paddles whilst in **D** will temporarily select manual gear selection mode. This will be automatically cancelled after a short period of driving at a steady speed, or can be cancelled by holding the (+) paddle for approximately one second.

Operation of the paddles in **S** will permanently select manual gear selection. Once selected, it will only be cancelled if the gear selector is moved into **D**.



JAG0442G

- To shift down, briefly pull the (-) paddle.
- To shift up, briefly pull the (+) paddle.

PARKING ASSIST



When **R** (Reverse) is selected, the Touch-screen displays a representation of the vehicle, and indicates any obstruction which is detected to the front or rear of the vehicle.

If an obstruction is detected, a coloured bar will be displayed showing it's approximate distance from the vehicle. This will be accompanied by an audible alert that increases frequency as the object is approached.

The volume of the alert can be changed via the **Vehicle - Parking** settings on the Touch-screen.

Parking assist is automatically cancelled when **D** (Drive) is selected, and the vehicle speed exceeds 15 km/h (9 mph).

Parking assist care points

Sensors may activate when water, snow, or ice, are detected on the surface of the sensors. This is normal for such sensors, and regular cleaning will maintain performance.

Quick Start

Parking assist may sound if it detects a frequency range close to that of the sensors (e.g. motorcycles, or air brakes).

CRUISE (SPEED) CONTROL

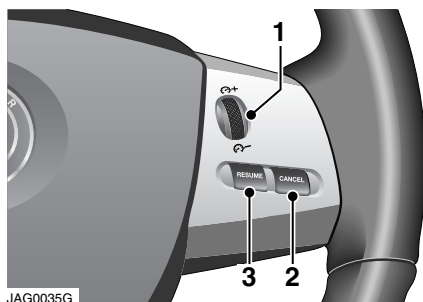

Speed control is the standard cruise control system which enables the vehicle to maintain a set road speed until either cruise control is cancelled, or the brake pedal is applied.

The system is controlled via switches on the steering wheel:

1. (+) or (-) to set the road speed to be maintained, or increase/decrease the speed in 2 km/h (1 mph) steps when cruise control is operating.
2. **CANCEL** - cancels cruise control, but retains the set speed in the memory.
3. **RESUME** - to resume a set speed retained in the memory.

Note: Cruise control will automatically disengage when the brake pedal is applied, or when the vehicle speed falls below 30 km/h (18 mph).

ADAPTIVE CRUISE CONTROL (ACC)



WARNING:

Adaptive cruise control is not a collision avoidance system

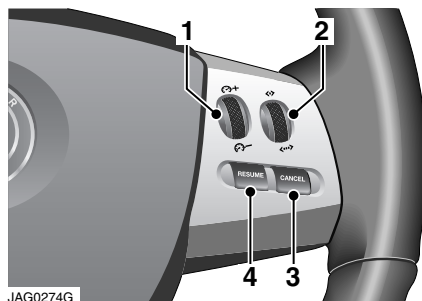

Adaptive cruise control is designed to aid the driver maintain a gap to the vehicle ahead, or to maintain a SET road speed if there is no slower vehicle ahead.

The system is controlled via switches on the steering wheel:

1. (+) or (-) to set the road speed to be maintained, or increase/decrease the speed in 2 km/h (1 mph) steps when cruise control is operating.
2. GAP - increase/decrease the time gap to the vehicle ahead.
3. **CANCEL** - cancels cruise control, but retains the set speed in the memory.
4. **RESUME** - to resume a set speed retained in the memory.

The gap to the vehicle ahead can be changed to one of four pre-defined intervals. The current setting will be displayed in the message centre.

Quick Start



If a slower vehicle is encountered or enters the same lane as you, the road speed will be adjusted to maintain the currently selected time gap. The warning light will illuminate to indicate that the vehicle is in follow mode.

Note: The system will not detect:

- Stationary, or slow moving vehicles below 10 km/h (6 mph).
- Pedestrians or objects in the roadway.
- Oncoming vehicles in the same lane.

TOUCH-SCREEN

The Touch-screen allows control of the audio, climate, phone, and navigation systems. The screen only requires a light touch to operate functions. Excessive pressure on the screen can result in damage to the screen.

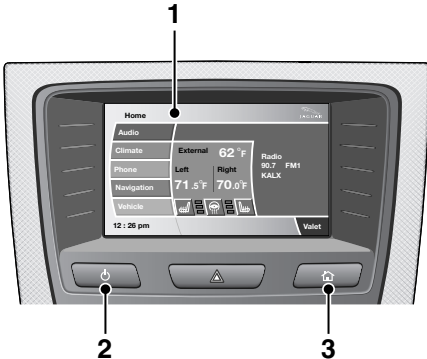

JAG044NAS

1. **Touch-screen.** When initially activated, the Touch-screen will display the **Home** screen.
2. **Touch-screen On/Off.** Press to turn the screen on.

Press to put the Touch-screen into screen saver mode, press again to turn off the screen.

3. **Home screen button.** Press at any time to return to the **Home** screen.



Most screens feature a return icon in the bottom right-hand corner.

Touch this icon to return to the previous screen.

SOUND SETTINGS

General operation

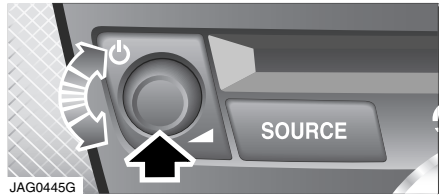

Press the control knob to switch on/off, and rotate to adjust volume.

Press the **SOURCE** button repeatedly to scroll through **FM1**, **FM2**, **AM**, and **CD** options.

Steering wheel controls

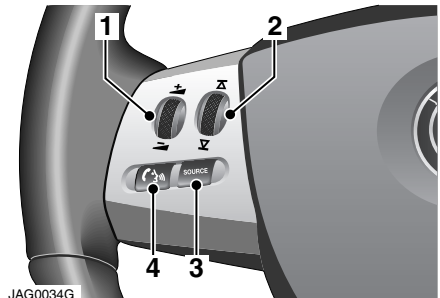

1. Rotate up or down to increase or decrease volume.

Quick Start

2. Rotate up or down to scroll through preset radio stations or CD tracks. Holding the wheel in the up or down position for two seconds will seek forward or backwards to the next available signal.
3. Press repeatedly to scroll through **FM1**, **FM2**, **AM**, and **CD** options.
4. Press to mute the audio unit. This button is also used in phone mode.

RADIO OPERATION

Caution: Ensure that the audio system is turned OFF so that the aerial is retracted before using an automatic car wash. Allow time for the aerial to retract.

From the Audio control screen, touch the **AM/FM** tab to select radio. Subsequent touches of this icon will scroll through the available wavebands.

Storing stations

Touch **Autostore** to automatically store the nine strongest signals.

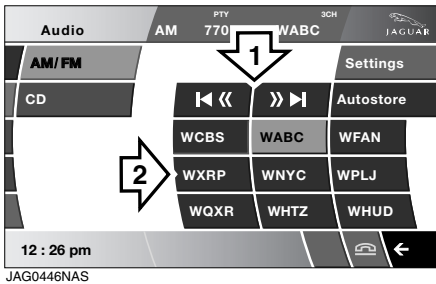

To manually store a station, search for the station using the seek icons **1**. Once the station has been found, touch and hold one of the station icons **2** to store the station. An alert tone sounds to indicate that the station has been stored.

The audio system has additional features which include: FM text, Traffic Announcements (TA), Programme Type (PTY), Regionalisation (REG), and Extended Other Networks (EON).

CD OPERATION

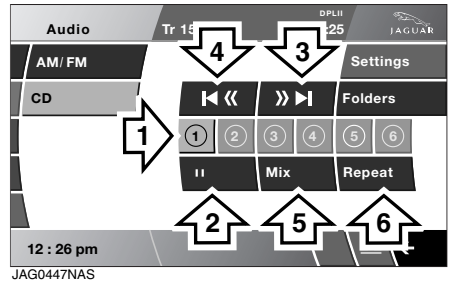

From the Audio control screen, touch the CD icon to access the CD player control screen. The CD player has an integral 6-disc multi changer. The example illustrated shows the multi changer loaded with four CD's, with one disc playing.

Loading CDs



Insert a CD into the slot label side up, a CD loading message is displayed. Press and hold the **LOAD** button, and follow the on-screen instructions. Continue to load CDs until the player is full, or you have inserted the desired number.



To eject the selected CD, press the eject button. Press and hold to eject each CD in turn.

Quick Start

Playing a CD

1. To play a CD touch the icon for the required CD number.

2.



To pause play press the pause icon, a further press will continue playback.

3.



Touch and release the skip forward icon to advance to the beginning of the next track. Touch and hold to advance through the current track, and subsequent tracks, until the icon is released.

4.



Touch and release the skip back icon to return to the previous track. Touch and hold to move back through the current track, and subsequent tracks, until the icon is released.

5. Touch and release **Mix** to randomly play tracks from the selected CD. Touch and hold for two seconds to play tracks randomly from all loaded CDs.
6. Touch and release **Repeat** to play the selected track again. Touch and hold for two seconds to play the entire disc again.

NAVIGATION

The Navigation system features include: Compass, Points of Interest, Memory Points, Split screen, Previous destination, and Route preferences. For details of these features refer to the Navigation Handbook.

Setting a destination

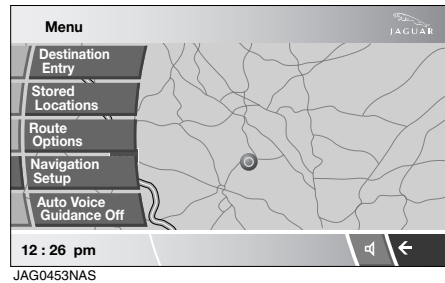

JAG0453NAS

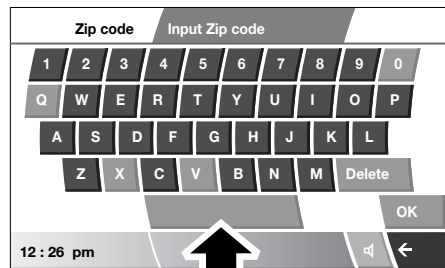

JAG0454NAS

To set a destination and start using the system:

1. Select **Navigation** from the home screen, and when prompted touch **Agree** to access the initial map screen.
2. Touch **Menu** to access the navigation menu, then touch **Destination Entry**. If the map is displayed, select **Menu** to access the **Destination Entry**.
3. Touch **Address** or **Postcode**.

Quick Start

4. Enter the **Town, Address,** and **House Number**, using the on-screen keypad. Select the **Display Map** button and then select **Destination**. For post code entry, enter the post code.
Select **OK** to enter.
5. Select **Destination** to confirm.
6. Once calculated, the screen displays Route 1. To view and select alternative routes, touch the **3 Route** icon.
7. Touch **Start** to commence navigation. Drive away following the voice guidance.

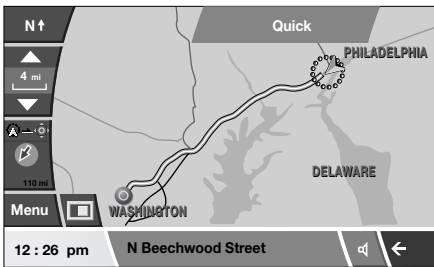

JAG0455NAS



Touch the audible repeat icon to hear the last voice instruction again. To mute voice guidance, go to the navigation **Menu** screen or, if the map is displayed, select **Menu**. Then select **Auto Voice Guidance Off** or **On** by touching the blue bar.

Upon arrival at your destination an audio announcement, and on-screen message will confirm your arrival.

Canceling guidance



To cancel guidance go to **Menu, Route Options, Cancel Guidance**.

TELEPHONE - BLUETOOTH SYSTEM

cell phones with Bluetooth capability can communicate with the vehicle's inbuilt telephone system.

The following procedure demonstrates how to connect the most popular brands of cell phone.

Pairing And Docking A Handset

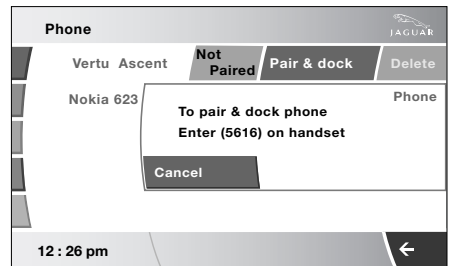

JAG0451NAS

1. Enable the cell phone's Bluetooth function. Refer to the handset manufacturer's instructions for guidance.
2. Select **Phone** from the **Home** screen.
3. If no phones have been Paired, **No phone found** will be displayed. Touch **Yes** to confirm a new phone search. The system will then search for Bluetooth enabled handsets in the vicinity.

Quick Start

- Once the system has recognised the handset, the name of the phone will appear on the phone list. Touch the **Pair & Dock** icon.
- The screen will display a random four-digit code. Enter the code to the handset and follow any instructions displayed on the handset.

When the handset has been successfully docked to the system, the **Digit Dial** screen is displayed.

Downloading phonebook entries

- Select **Phone** from the **Home** screen.
- Touch **Settings**, then select **Phone Options**.
- Select Phonebook from the Menu.
- Ensure that **Auto Download** is on. All the numbers in your cell phone will be transferred to the vehicle's system the next time that the phone is connected to the system.



JAG0452NAS

Making a call

- With a paired and docked handset, select **Phone** from the **Home** screen.
- From the **Digit Dial** screen, enter the number using the on-screen keypad.
-



Touch the phone icon on the screen,



or the call button on the steering wheel control.

The call duration will appear on the Touch-screen.

Receiving A Call

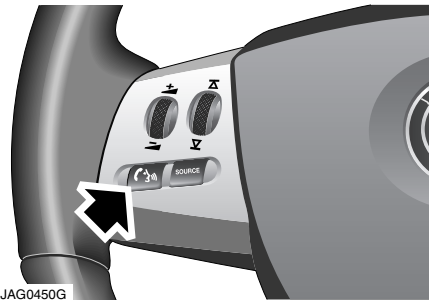

To answer or end a call touch **Accept** on the screen, or press the call button on the steering wheel control.

Filling Station Information

FUEL TYPE

Unleaded 91 Octane

Caution: This vehicle is not suitable for use with fuels containing more than 10 per cent ethanol. Do not use E85 fuels (85 per cent ethanol content).

Equipment necessary for the use of fuels containing more than 10 per cent ethanol is not fitted to this vehicle. If E85 fuels are used, serious engine and fuel system damage will occur.

Fuel filling

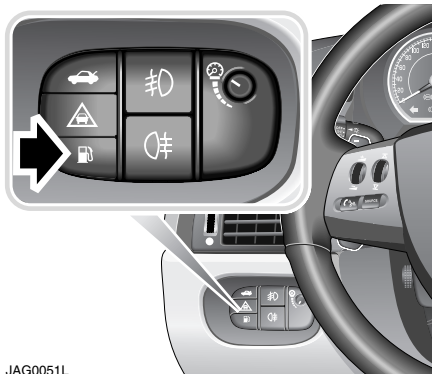

JAG0051L

Press the fuel filler flap release, located on the driver's knee bolster switchpack below the facia, see 'FUEL FILLER FLAP', page 52.

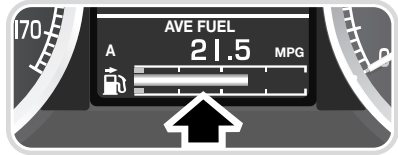
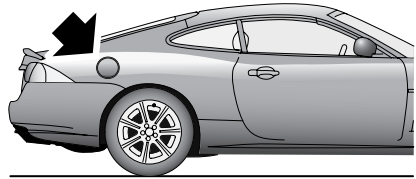

JAG0054NAS

The filler flap is located on the right-hand side of the vehicle.

When refuelling, ensure that the fuel nozzle rests on the bottom of the filler neck.

Refit the fuel filler cap by twisting the filler cap clockwise until it clicks. Close the flap, which automatically locks shut.

Incorrect replacement of the fuel filler cap may result in check engine warning indicator (malfunction warning indicator, MIL) illuminating.

Filling Station Information

HOOD RELEASE



JAG0056G

Pull the release lever located below the fascia on the left-hand side of the vehicle, see 234.

UNDERHOOD TOP-UP

Recommended engine oil.

Castrol 5W-30 to Jaguar specification WSS M2C913 - A or B, see page 237.

Windshield and headlamp washer reservoir.

See page 239.

Coolant system

50% water 50% antifreeze, see page 238.

TIRE PRESSURES

Tire pressure label USA only

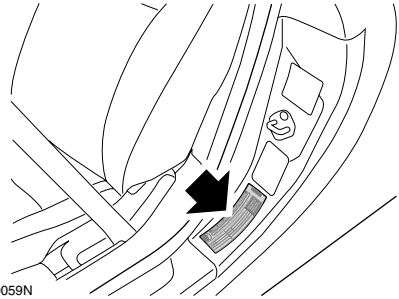

JAG0059N

The recommended tire pressures for all normal operating conditions, are shown on a label fixed to the pillar behind the driver's door.

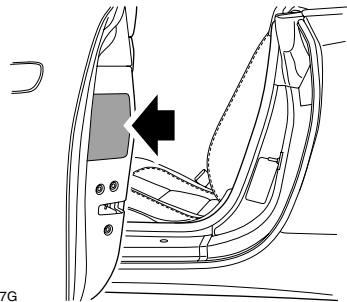

JAG0057G

Canada and Mexico only: The recommended tire pressures for all normal operating conditions, are shown on a label fixed to the end of the driver's door.

For your convenience you may wish to record the tire pressures in the boxes provided below. If you are unsure of the correct pressures, please contact your Jaguar Dealer.

Filling Station Information

	FRONT
Normal Driving	<input type="text"/>
Laden/High Speed	<input type="text"/>
	REAR
Normal Driving	<input type="text"/>
Laden/High Speed	<input type="text"/>
Spare Wheel	<input type="text"/>



WARNING:

When using tires other than those recommended by Jaguar, do not exceed the speed capacity recommended by the manufacturer.

TIRE PRESSURE MONITORING SYSTEM

The Tire Pressure Monitoring System (TPMS), see page 267, monitors the pressures of the tires, providing a warning of low tire pressure.

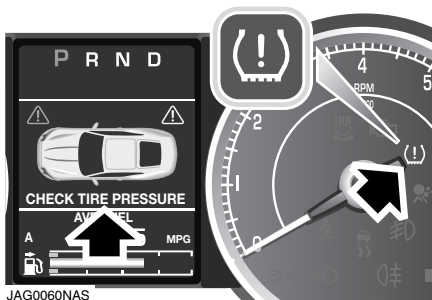

JAG0060NAS

If a warning appears one, or more, of your tires are significantly under-inflated. You should stop and check your tire pressures as soon as possible. They should be inflated to the recommended pressure. If warnings appear repeatedly, the cause must be investigated and rectified.

Check pressures when the tires are cold. Deflating a warm tire to the recommended cold inflation pressure, will result in dangerous under-inflation.

ULTRA HIGH PERFORMANCE TIRES

Caution: Ultra high performance tires.

This vehicle is equipped with an Ultra High Performance (UHP) tire and wheel combination designed to give maximum dry road performance with consideration for aquaplaning resistance. UHP tires have performance enhancing soft rubber tread compound. If driven aggressively they may suffer rapid tread wear and a shorter life than can be expected from other tire types. This wheel and tire combination is more susceptible to damage from road hazards.

Do not use this combination for driving on snow or ice. High performance tires must be replaced with winter tires when weather conditions dictate.



Tires with an all season icon and or M+S marking have a level of winter performance and need not be replaced.

Introduction

HEALTH AND SAFETY



WARNING:

California Proposition 65:
Engine exhaust, some of its constituents and certain vehicle components, contain or emit chemicals known to the State of California to cause cancer and birth defects or other reproductive harm. In addition, certain fluids contained in vehicles and certain products of component wear contain or emit chemicals known to the State of California to cause cancer and birth defects or other reproductive harm.

SYMBOLS GLOSSARY

Warnings, cautions and notes

Take particular note of WARNINGS, Cautions and Notes given throughout this handbook.



WARNING:

Warnings are displayed in this handbook to help avoid the risk of personal injury.

Caution: Cautions are displayed in this handbook to reduce the possibility of damage to the vehicle.

Note: Notes are used to help avoid difficulties in the operation of the vehicle.

Warning symbols on the vehicle

Caution: Do not remove any warning labels from the vehicle.



JAG0063G



These symbols advise you to read the handbook before touching this part of the vehicle or attempting adjustments of any kind.

Introduction

Label locations

Shown below are the main locations that contain vehicle warning and information labels:

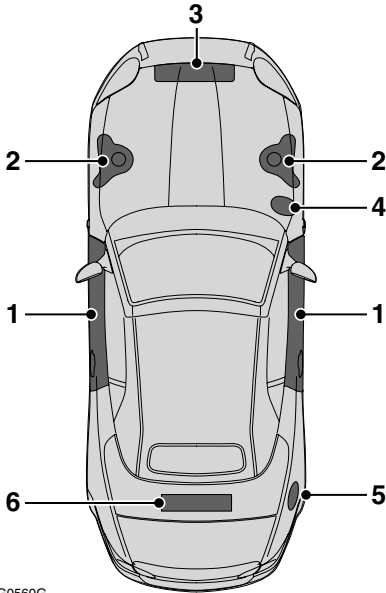

JAG0560G

1. Vehicle certification.
Air bag.
Child restraint.
Tire placard.
2. Air conditioning.
Emissions.
3. Under hood warnings.
4. Coolant warnings.
5. Fuel warnings.
6. Battery.

PARTS AND ACCESSORIES



WARNING:

Do not fit unapproved accessories or conversions, as they could affect the safety of the vehicle.

Jaguar Cars Limited will not accept any liability for death, personal injury or damage to property which may occur as a direct result of fitment of non-approved conversions to Jaguar vehicles.

Jaguar Cars Limited strongly advise against making any modifications to the suspension or steering systems. This could seriously affect the handling and stability of the vehicle leading to loss of control or roll-over.

The use of non-genuine parts and accessories may invalidate the vehicle warranty.

Genuine Jaguar parts and accessories

Your Jaguar Dealer can supply you with genuine replacement parts and accessories which are fully approved to Jaguar's original equipment specification.

Electrical accessories



WARNING:

Alterations to the electrical system, including the fitting of accessories not designed for this Jaguar, will cause damage to the electrical systems. This could result in a malfunction or fire. All accessory work should be entrusted to a Jaguar Dealer.

Introduction

Ground points

Caution: Under no circumstances must holes be drilled in the bodywork to accept ground terminals.

If an accessory needs to be connected to a ground point, it is advisable to consult a Jaguar Dealer.

DATA RECORDING

Service data recording

Service data recorders in your vehicle are capable of collecting and storing diagnostic information about your vehicle. This potentially includes information about the performance or status of various systems and modules in the vehicle, such as engine, throttle, steering or brake systems.

In order to properly diagnose and service your vehicle, Jaguar Cars Limited and service and repair facilities may access vehicle diagnostic information through a direct connection to your vehicle when diagnosing or servicing your vehicle.

Event data recording

Other modules in your vehicle - event data recorders - are capable of collecting and storing data during a crash or near crash event. The recorded information may assist in the investigation of such an event. The modules may record information about both the vehicle and the occupants, potentially including information such as:

- How various systems in your vehicle were operating.
- Whether or not the driver and passenger seat belts were buckled.

- How far, if at all, the driver was depressing the accelerator and/or the brake pedal.
- How fast the vehicle was travelling.
- Where the driver was positioning the steering wheel.

To access this information special equipment must be directly connected to the recording modules. Jaguar Cars Limited do not access event data recorder information without obtaining consent, unless pursuant to court order or where required by law enforcement, other government authorities or third parties acting with lawful authority.

Other parties may seek to access the information independently of Jaguar Cars Limited.

Reporting Safety Defects

Vehicle defects (U.S. Only)

If you believe that your vehicle has a defect which could cause a crash or could cause injury or death, you should immediately inform the National Highway Traffic Safety Administration (NHTSA) in addition to notifying Jaguar Cars.

If NHTSA receives similar complaints, it may open an investigation, and if it finds that a safety defect exists in a group of vehicles, it may order a recall and remedy campaign.

However, NHTSA cannot become involved in individual problems between you, your Dealer, or Jaguar Cars.

To contact NHTSA, you may call the Vehicle Safety Hotline toll-free at 1-888-327-4236 (TTY: 1-800-424-9153); go to <http://www.safercar.gov>; or write to:

Administrator,
NHTSA,
400 Seventh Street SW.,
Washington, DC. 20590.

To contact Jaguar Cars, call 1-800 4 Jaguar.

You can also obtain other information about motor safety from <http://www.safercar.gov>.

Vehicle defects (Canada only)

If you believe that your vehicle has a defect which could cause a crash or could cause injury or death, you should immediately inform Transport Canada in addition to notifying Jaguar Cars.

To contact Transport Canada, call their toll-free number 1-800-333-0510.

Keys and Remote Controls

PRINCIPLE OF OPERATION

The security system and entry to the vehicle are controlled by the Jaguar Smart Key. Both doors and the luggage compartment can be locked and unlocked using the remote control buttons.

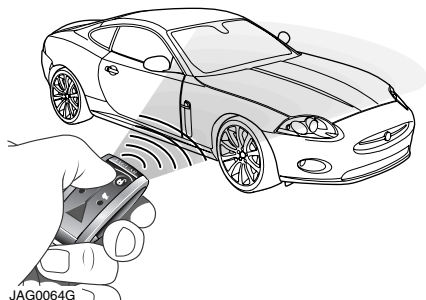

Keyless Entry is an enhancement of the Jaguar Smart Key. It allows entry to the vehicle without any button pressing.

Full security integrity of the vehicle is still maintained, see **Keyless Entry** page 41.

The remote control also allows the vehicle to be started without the use of an ignition key - **Keyless Starting**, see page 50.

Two handsets, comprising of a transmitter body with a detachable metal emergency key blade are supplied. Separate emergency key blades are available from Jaguar Dealers.

Caution:

- **Remove all remote controls from the vehicle when it is left unattended. This will ensure the vehicle is left in a secure condition.**
- **If a remote control is lost, a replacement can be obtained and programmed to the vehicle by a Jaguar Dealer. Notify a Jaguar Dealer as soon as a remote control is lost or stolen and have the remaining remote control(s) reprogrammed.**

The emergency key blade number is recorded on an attached label. Peel off the label and attach it to the designated area on the Security Card supplied in the vehicle literature pack. Keep the Security Card safe, but not in the vehicle.

Keys and Remote Controls

USING THE REMOTE CONTROL

The remote handset, Jaguar Smart Key, allows the vehicle to be unlocked and the engine to be started without the use of an ignition key - Keyless Starting, see page 50.

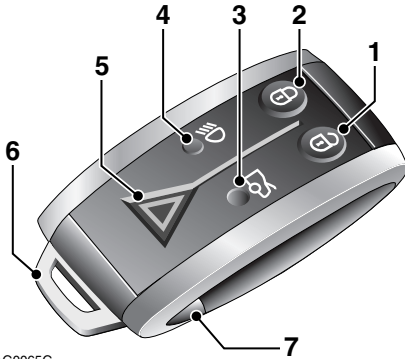

JAG0065G

1. Unlocks and disarms the vehicle.



Central unlocking

One press: Unlocks all doors and the luggage compartment.

The direction indicators will flash twice.

Two stage unlocking

One press: Unlocks the driver's door and the luggage compartment. The direction indicators will flash twice (in certain markets two audible warnings will be emitted).

Two presses (within three seconds):

Unlocks the passenger door.

Note: Changing from central locking to two stage locking and back again can be carried out by pressing the lock and unlock buttons simultaneously for four seconds or via the touch-screen, see page 46. The directional indicators will flash twice to confirm that the change has been carried out.

Press and hold the button to globally open the vehicle windows, if enabled, see page 47. Press and hold opens all windows as well as the programmed door opening.

2. Locks and arms the vehicle.



First press (if vehicle is unlocked and disarmed):

Locks all doors, luggage compartment and sets the alarm system. The direction indicators will flash once.

3. Releases the luggage compartment lock.



When the vehicle alarm system is armed and the luggage compartment only is opened, the door and hood security is still active. The doors will remain locked and armed. See page 43.

4. Activates the convenience headlamp feature.



One press switches on headlamps. The headlamps will remain on for 25 seconds, or until the button is pressed again, or until the engine START/STOP button is pressed.

Keys and Remote Controls

5. Activates the panic alarm.



Press the button three times within three seconds.

The alarm is stopped by:

- Pressing the button again three times within three seconds.
- Inserting the Jaguar Smart Key into the starter control unit, see page 37.
- The vehicle detecting a valid Jaguar Smart Key when the START/STOP button is pressed.

Note: *The panic alarm cannot be cancelled within the first 5 seconds of the alarm activating.*

6. Emergency key blade.

To use the emergency key blade see page 45.

7. Emergency key blade release button.



JAG0075G

To extract: press the release button and hold while withdrawing the key blade.

To insert: press and hold the button and push the key blade into the Jaguar Smart Key transmitter housing.

To extract: press the release button and hold while withdrawing the key blade.

The key blade operates the door lock on the left-hand side of the vehicle, the luggage compartment lock and glove compartment lock, see page 45.

Care of the remote handset

Do not expose to extremes of heat, dust, humidity or allow contact with fluids. Do not leave the transmitter exposed to direct sunlight.

Keys and Remote Controls

Irregular remote control operation

If difficulty is experienced with remote keyless entry, passive entry, passive starting or Jaguar Smart Key operation, it may be caused by:

- internal battery low voltage and therefore the battery should be replaced, see page 40, or
- high levels of localised external electrical interference e.g. radio transmitter.

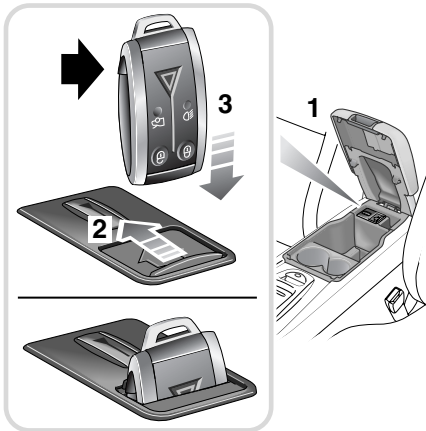

JAG0066G

Until the battery can be replaced, or until the vehicle is outside the local electrical interference zone, the Jaguar Smart Key must be inserted into the starter control unit.

1. Lift the lid of the centre console stowage compartment.
2. Slide open the cover of the starter control unit.
3. Insert the Jaguar Smart Key into the recess with the emergency key release button facing forward.

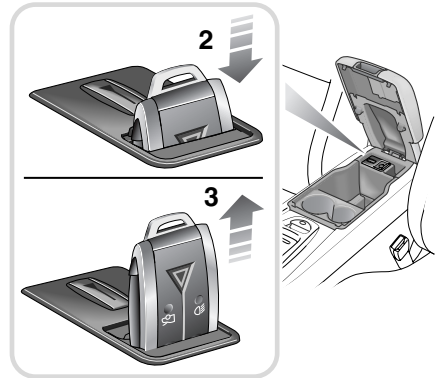
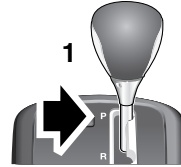

JAG0061G

To remove the Jaguar Smart Key from the starter control unit:

1. Ensure that the vehicle is at rest with the gear selector in the **P** position and the engine not running.
2. Carefully depress the Jaguar Smart Key and release. The key will eject into its rest position.
3. Remove the Jaguar Smart Key from the starter control unit.

Note: This is not a Jaguar Smart Key internal battery recharging procedure. The battery is non-rechargeable.

Keys and Remote Controls

Message centre information displays

Message	Warning Light	Priority Indicator	Meaning
SMART KEY NOT FOUND, PLEASE INSERT IN SLOT	None	None	The Jaguar Smart Key has not been detected, insert into the starter control unit, see page 37.
CHECK SMART KEY	None	None	Check that the Jaguar Smart Key is in the vehicle.
WRONG SMART KEY FOUND	None	None	The Jaguar Smart Key detected by the in-vehicle systems is not the one belonging to the vehicle.
REMOVE SMART KEY	None	None	Remove the Jaguar Smart Key from the starter control unit.

Keys and Remote Controls

Jaguar Smart Key system transmitters



WARNING:

Any person fitted with an implanted pacemaker should ensure that the pacemaker is kept at a distance of at least 22 cm (8.7 inches) away from any transmitter mounted in the vehicle.

This is to avoid any possibility of interference between the system and pacemaker.

1. Cabin front transmitter.
2. Keyless vehicle module.
3. Cabin rear transmitter.
4. Exterior door handle transmitters.
5. Luggage compartment interior transmitter.
6. Luggage compartment exterior transmitter.

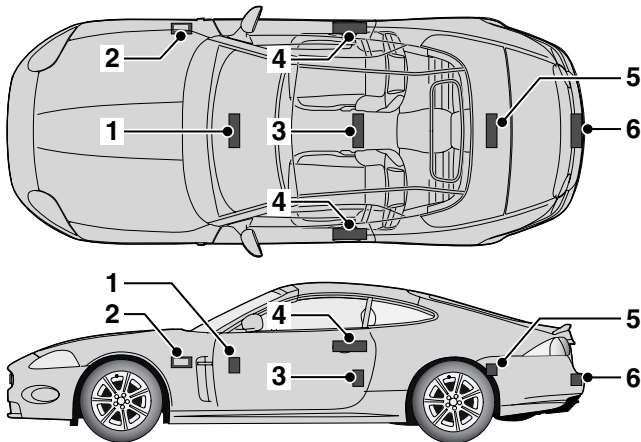

JAG0543G

Keys and Remote Controls

CHANGING THE REMOTE CONTROL BATTERY

Battery renewal

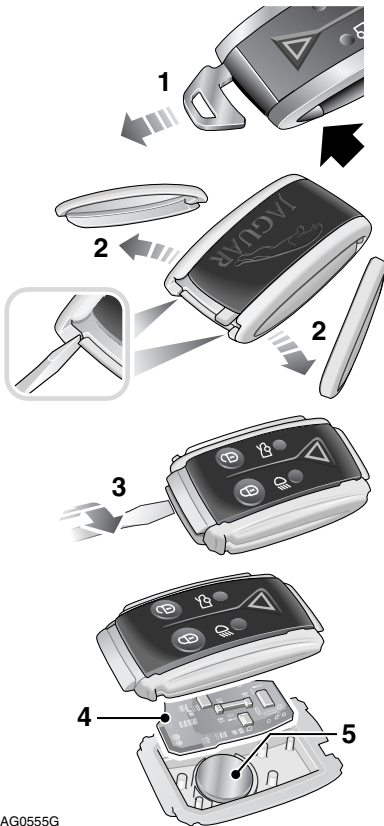

JAG0555G

When the battery needs renewing there will be a significant decrease in the effective range of the key transmitter and the message **SMART KEY BATTERY LOW** is displayed on the message centre.

To renew the battery, follow the procedure below:

1. Remove the key blade from the Jaguar Smart Key, see page 36.
2. Remove the two side covers, one at a time, by inserting a small, flat blade, screwdriver between the cover and body and lightly twist the screwdriver.
3. Insert a small, flat bladed, screwdriver between the two body halves of the remote control. Apply light pressure to the screwdriver and separate the two halves.
4. Remove the printed circuit board, taking care not to touch the battery terminals. Remove the old battery and dispose of it safely.
5. Fit a new battery cell, type CR2032 (available from your Jaguar Dealer), with the side marked with the positive symbol (+) downwards in the battery receptacle. Avoid touching the new battery as moisture/oil from the fingers can reduce the life of the battery and corrode the contacts.

Refit the parts in the reverse order ensuring that they click securely into place.

Locks

KEYLESS ENTRY

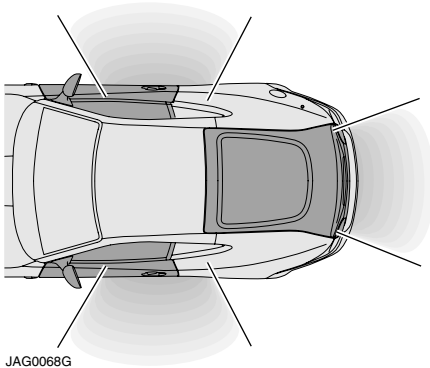

The **Keyless Entry** function operates in the following manner:

Central locking:

1. As a door handle is operated, the vehicle emits a search signal.
2. As long as the Jaguar Smart Key is within approximately 1.0m (3 feet 3 inches) of the operated door handle, the signal will be acknowledged.

Note: The Jaguar Smart Key requires only to be on the driver's person or in a bag or a non-metallic briefcase; it does not require to be exposed or handled.

3. The vehicle accepts the valid response and allows access via either door. The direction indicators will flash twice (in certain markets two audible warnings will be emitted).

Note: You are unlikely to notice a time lag during this momentary process.

Two stage unlocking: Access to the vehicle is via the first door handle operated. The other door can be opened by releasing the internal door lock or via operating the exterior door handle with a Jaguar Smart Key present.

Note: Changing from central locking to two stage locking and back again can be simply carried out by pressing the lock and unlock buttons simultaneously for four seconds. The directional indicators will flash twice to confirm the change.

Jaguar Smart Key check

When the last open door is closed, the vehicle will perform a search of the vehicle interior for the Jaguar Smart Key. If one is not found a message **SMART KEY NOT FOUND, PLEASE INSERT IN SLOT** will be displayed for four seconds on the message centre. This is to alert the driver that the Jaguar Smart Key may have been inadvertently removed from the vehicle.

LOCKING AND UNLOCKING



WARNING:

The door windows partially lower and raise automatically when the door is opened and closed. Keep fingers away from the windows when closing the door. Closing an electrically operated window on fingers, hands or any vulnerable part of the body, can result in serious injury.

Note: It will not be possible to lock the vehicle if any door, hood or luggage compartment is ajar or the inertia switch has been tripped, see page 223. An audible warning will be emitted.

Locks

Convenience Mode

As the door is opened, the vehicle's electrical system initiates the **convenience mode**. The following systems become functional:

- memory
- seat and steering column adjustment
- interior and exterior lighting
- message centre
- cigar lighter and power socket.

Door external lock operation - with Keyless Entry

Note: The keyless locking system will only activate if the remote handset is outside the vehicle.

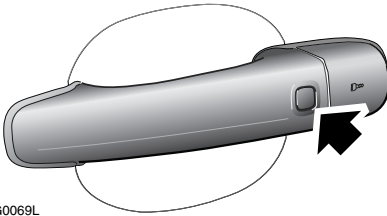

JAG0069L

To lock the vehicle and set alarm

1. Press the button on the door handle once, or;
2. Use the Jaguar Smart Key.

Note: The vehicle will not lock automatically.

Anti-slam locking

This feature helps prevent locking the remote handset in the vehicle.

If either the driver's or passenger's door is open and an attempt is made to lock the doors using the interior locking levers, the doors will not lock, due to a mechanical inhibitor.

The vehicle can be locked using the touch-screen lock, the remote handset (when outside the vehicle) when all the doors are closed.

Door external lock operation - without Keyless Entry



JAG0520G

Press the remote control lock button **1** or use the emergency key blade **2**, see page 45.

Locks

Door interior lock operation

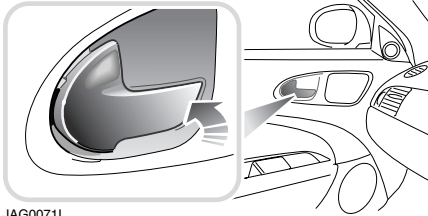

JAG0071L

To lock: Press the door release lever inwards to lock both doors and luggage compartment.

To unlock: Pull the door release lever.

Drive-away door locking

This feature locks all the doors and luggage compartment if they are unlocked when the gear selector is moved out of the **P** position and the vehicle is moving forward at the set speed of above 7 km/h (5 mph).

Drive-away locking can be disabled or reinstated by use of the touch-screen, if required, see page 46.

Luggage compartment locking and unlocking

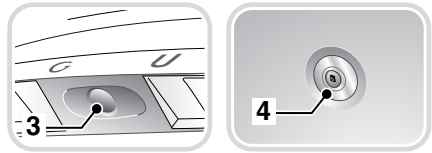
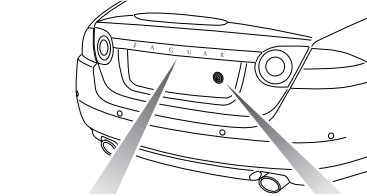

JAG0073L

All vehicles

The luggage compartment can be opened by:

- Pressing the luggage compartment release switch **1** on the facia switchpack.
- Pressing the luggage compartment release button **2** on the remote handset.

Note: If the vehicle is armed the alarm will not activate, but will re-arm when the luggage compartment lid is closed again.

- With the vehicle unlocked, press the release button **3** on the luggage compartment lid. However, it will be inhibited if the valet mode is set.

Locks

- The key blade can be used to open the luggage compartment release lock **4**, located behind the number plate, but this will cause the alarm to sound.

Caution: If the luggage compartment is opened after the driver and passenger doors are locked, ensure the Jaguar Smart Key remains outside the vehicle when it is closed again.

Vehicles without Keyless Entry

If the Jaguar Smart Key is inadvertently left inside the vehicle, you will be locked out. You should contact your Jaguar Dealer.

Vehicles with Keyless Entry

Caution: If the Jaguar Smart Key is inadvertently left inside the vehicle, an audible alarm will sound and the luggage compartment lid will re-open after three seconds.

Note: *If the Jaguar Smart Key is placed in a metal container, it will not be detected.*

All Jaguar Smart Keys must be removed from the vehicle before locking.

Luggage compartment emergency release

1

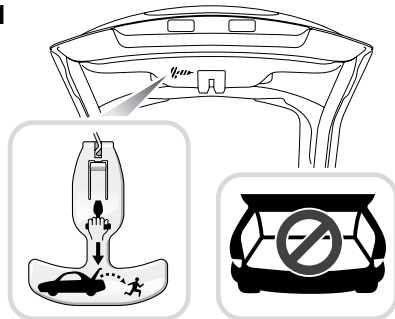

2

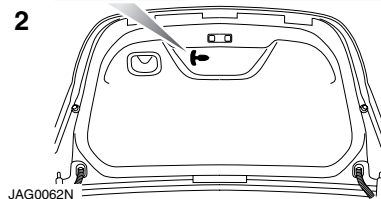

Your vehicle is equipped with a mechanical interior luggage compartment release handle that provides a means of escape for children and adults in the event they become locked inside the luggage compartment.

Adults are advised to familiarise themselves with the operation and location of the release handle.

The T-shaped handle is located on the luggage compartment lid, coupe **1** and convertible **2**.

To open the luggage compartment lid from the inside, pull the T-shaped handle and push up the lid. The material that the handle is made of will glow for hours in the darkness of the luggage compartment following brief exposure to ambient light.

Locks

Ensure that the T-shaped handle is firmly returned to its stowed position after use.



WARNING:

- **Keep vehicle doors and the luggage compartment locked and keep keys out of a child's reach. Unsupervised children could lock themselves in an open compartment and risk injury. Children should be taught not to play in vehicle.**
- **On hot days, the temperature in the luggage compartment and the vehicle interior can rise very quickly. Exposure of people or animals to these high temperatures for even a short time can cause death or serious heat-related injuries, including brain damage. Small children are particularly at risk.**

Emergency key blade operation

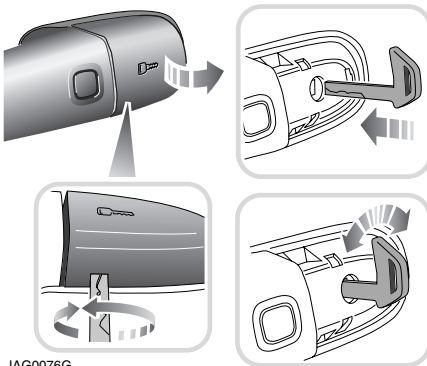

JAG0076G

Remove the left-hand door handle key lock cover by inserting the key blade into the rectangular hole on the underside of the cover.

Push up and twist the key blade to release the cover retaining clips. Insert the key blade into the exposed lock.

Note: *Ensure that the emergency key blade is kept safely at all times.*

To lock the vehicle

Turn the key blade towards the front of the vehicle and release.

This will lock the doors and the luggage compartment, but will not arm the vehicle.

Unlocking

To unlock the vehicle

Turn the key blade towards the rear of the vehicle and release. This unlocks the left-hand side door and the luggage compartment and turns on the interior lights for two minutes at $\frac{3}{4}$ brightness.

When the vehicle is unlocked in this manner, and a door is opened, this will activate the full alarm. To disarm the vehicle, press the Jaguar Smart Key unlock button or stow it in the starter control unit, see page 37, or press the engine START/STOP button.

The direction indicators give two flashes (in certain markets two audible warnings will be given).

Valet mode

Valet mode allows the vehicle to be parked by a parking attendant who can lock the vehicle after parking, but cannot open the luggage or glove compartments.

The key blade is used to lock the glove compartment. The touch-screen sets the valet mode for securing the luggage compartment, see **PROGRAMMING THE REMOTE CONTROL** on page -46.

Locks

PROGRAMMING THE REMOTE CONTROL

The remote handset, Jaguar Smart Key, and various features of the vehicle security system can be programmed to your individual requirements by use of the touch-screen.

The programmable features are as follows:

- drive-away locking
- central or two stage locking
- sensor override
- window global open or close, passive entry vehicles only
- valet key mode.

Selecting drive-away locking

From the main **Home** touch-screen menu, select **Vehicle**:

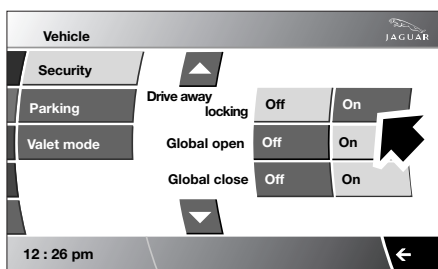
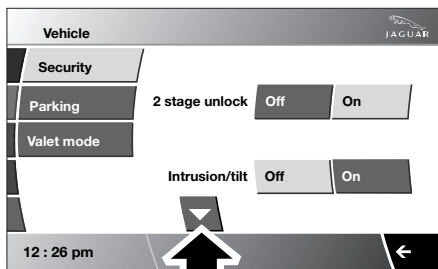

JAG0526NAS

1. Select **Veh. settings**.
2. The **Security** button is selected automatically as the default.
3. Scroll down to - **Drive away locking** - and select either **On** or **Off**.

Locks

Selecting central or two stage locking

From the main **Home** touch-screen menu, select **Vehicle**:

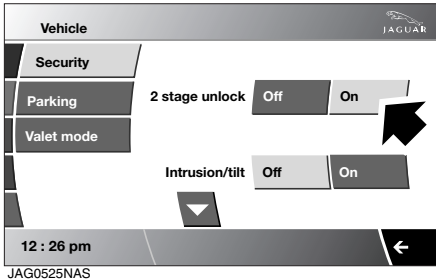

1. Select **Veh. settings**.
2. The **Security** button is selected automatically as the default.
3. Select: - **2 stage unlock - On** or **Off**.

Valet mode

From the main **Home** touch-screen menu, select **Vehicle**:

1. Select **Veh. settings**.
2. The **Security** button is selected automatically as the default.
3. Select **Valet mode**.
4. Enter a four digit Personal Identification Number (PIN) (personally chosen) by touching the digit screen pad. On completion touch the **OK** button. The screen indicates that the PIN has been accepted by displaying **Valet on**. If you wish to cancel the PIN, touch the **C** button at any time during entering the number.

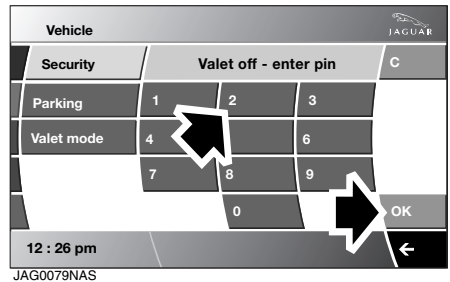

- Using the key blade, lock the glove box.
- The luggage compartment is now securely locked in the valet mode.
- On exiting and securing the vehicle, hand the Jaguar Smert Key, less the key blade, to the attendant.

Note: Ensure that the emergency key blade is kept safely at all times.

De-selecting valet mode: When entry into the vehicle has been gained, access the **Valet mode** screen.

Locks

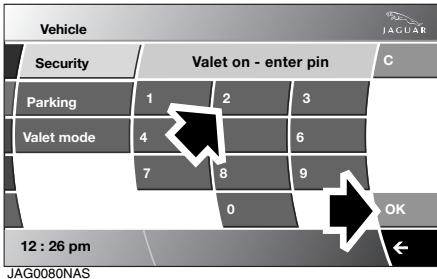

1. Enter your four digit PIN and touch the **OK** button. The screen will indicate that your PIN has been accepted by displaying **Valet off**.
2. The luggage compartment will return to the previously set security requirement.
3. Unlock the glove box using the key blade.
4. Insert the key blade into the Jaguar Smart Key.

Note: If the PIN number has been forgotten, the luggage compartment can be unlocked by using the key blade in the luggage compartment lock. This will cancel the valet mode, see page 43.

Alarm

ARMING THE ALARM

Some items may not be available, contact your Jaguar Dealer if you are unsure.

Passive arming of the automatic alarm system, can be programmed by a Jaguar Dealer. This ensures that the security system arms itself 30 seconds after the doors, hood and luggage compartment are closed following removal of the remote handset from the vehicle.

Standard alarm features cover the perimeter sensing of hood, doors and luggage compartment.

Note: *Passive arming does not lock the doors.*

Alarms and audible signals

Note: *In certain markets, legislation prohibits the use of audible confirmation signals.*

Audible signals

Two audible warnings (error signal) will sound if an attempt is made to lock the vehicle if a door, hood or luggage compartment is not fully closed.

Full alarm

Once armed, any of the following circumstances will create a full alarm state, sound the siren or horns and flash the direction indicators:

- opening a door, luggage compartment (except with remote handset) or hood
- using a remote handset in the starter control unit which is not programmed to the vehicle.

Remote headlight convenience

By pressing the remote handset transmitter button with the dipped headlight symbol once, the headlights will come on for 25 seconds, unless the headlight button is pressed again, or if the engine START/STOP button key pressed.

DISARMING THE ALARM

Using the remote control

See page 35 and 41.

Using the key blade

See page 45.

PANIC ALARM



JAG0081G

When in or near the vehicle, the panic alarm can be set off to deter a possible offender.

Pressing the panic button on the remote handset transmitter three times within three seconds will activate the **panic alarm**.

The alarm is stopped by inserting the remote handset in the starter control unit or by pressing the panic button on the key transmitter three times within three seconds or holding the panic button down for three seconds.

Note: *The panic alarm is not functional if the ignition system is ON.*

Starting the Engine

KEYLESS STARTING



WARNING:

Before starting the engine, check the parkbrake is ON and the gear selector is in position P.

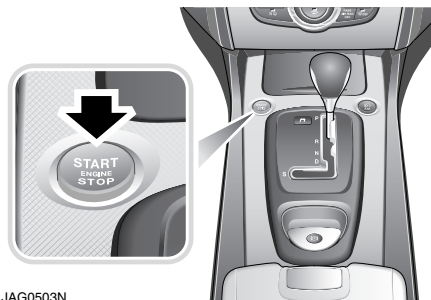

JAG0503N

With the brake pedal depressed, press the START/STOP button to start the engine. All systems will become functional.

Note: If the fuel system inertia switch has been tripped, the ignition system will be isolated, see page 223.

If the engine persistently fails to start, press the START/STOP button to turn the ignition system back to **convenience mode**. Slowly depress the accelerator pedal fully, hold it in this position and press the START/STOP button with the brake pedal applied, the engine will start to crank. Release the accelerator pedal when the engine starts.

Note: If the Jaguar Smart Key is placed in the door pocket it will be outside the range of the sensors when the door is opened.

When pressing the engine START/STOP button to start the engine, if the security status light, on the top surface of the instrument panel, remains flashing, a fault condition is indicated. Seek qualified assistance as soon as possible.

Ignition system ON, non-engine start

To turn on the ignition system without starting the engine, press the START/STOP button without pressing the brake pedal. All systems will become functional.

Rolling re-start

If the engine is switched off while the vehicle is moving, a rolling re-start can be initiated by selecting neutral, **N**, and pressing the engine START/STOP button.

SWITCHING OFF THE ENGINE

Caution: Never switch OFF the engine whilst the vehicle is in motion.

With the gear selector in position **P**, press the engine START/STOP button. The engine will stop and the electrical system will return to the **convenience mode**. The audio, telephone and touch-screen systems will revert to stand-by mode. Pressing the START/STOP button again will activate the systems.

Engine Immobiliser

CODED KEYS

This vehicle is equipped with a Passive Anti-Theft System (PATS) which prevents it from being driven away by an unauthorised person.

A sophisticated decoding process is used to validate the Jaguar Smart Key. The engine can only be started by the key that is programmed to the vehicle electronic systems.

Driving Hints

RUNNING-IN

Apart from a few precautionary recommendations, there are no strict running-in procedures for this vehicle.

By observing the following advisory precautions you will ensure maximum engine, transmission and brake life for your vehicle:

Engine

- Allow the engine to reach operating temperature before operating at engine speeds over 3500 rev/min.
- Vary the speed frequently.
- From 1500 kilometres (940 miles) onwards, gradually increase performance of the vehicle up to the permitted maximum speed.

Engine oil consumption

A certain amount of oil consumption is normal. The rate of consumption will depend on the following:

- The quality and viscosity of the oil.
- Climatic conditions.
- The speed at which the engine is being operated.
- Road conditions.

Drivers should expect above normal consumption when the engine is new, and after running-in if high speeds are sustained.

Brakes

To ensure that brake pads reach their optimum wear and performance condition, usually within 480 kilometres (300 miles), observe the following points are recommended.

- Where possible, avoid heavy braking as this can result in damage to the brake pads and discs.
- Avoid prolonged use of the brakes, for example, when descending severe gradients.
- Frequent light application of the brakes is desirable. This helps to fully bed-in the brake pads.

Final drive unit

During the first 1500 kilometers (940 miles):

- Avoid full throttle applications and do not exceed 190 km/h (120 mph). Observe the national speed limits in the country in which you are travelling.
- Do not participate in motor racing events, test track days, sports driving schools or similar for the first 8000 kilometers (4975 miles), also see page 161.

Steering Wheel

ADJUSTING THE STEERING WHEEL

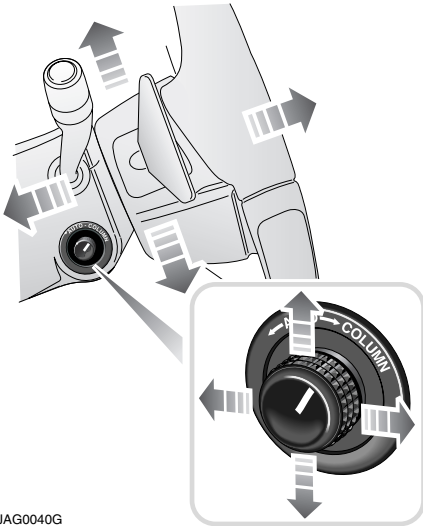

JAG0040G



WARNING:

Do not adjust the steering wheel whilst driving.

Caution: Do not use steering wheel mounted security devices since movement of the steering wheel in entry or exit mode could result in damage to the vehicle (e.g. the windshield) or possible injury to the occupant.

The steering wheel can be adjusted for tilt and reach.

1. Turn the switch to the **COLUMN** or **AUTO** position 1.
2. Move the switch forwards or backwards to adjust reach.

3. Move the switch up or down to adjust tilt.

Three steering wheel positions may be stored and recalled by the driver position memory system, refer to Memory Setting on page 139.

The message centre will indicate which switch position has been selected by displaying the message **COLUMN ADJUST** or **COLUMN ADJUST AUTO**.

Entry and exit mode

Entry and exit mode provides automatic movement of the steering column to allow easier entry to or exit from the vehicle.

Entry and exit mode is selected by setting the steering column adjustment switch to the **AUTO** position 2.

Exit: - If the ignition system is in the **convenience mode** position and the driver's door is opened, the steering column will move to the uppermost tilt position, unless already in that position.

Entry: - When the door is closed and the Start button is pressed, the steering column will return to the previous position.

Notes on entry and exit mode operation

- If the steering column switch is moved away from **AUTO** whilst the steering column is tilted away, the steering column will move back to its previous position when the driver's door is closed and the Start button is pressed.
- If the steering column is adjusted during entry and exit operation, steering column movement will stop.

Steering Wheel

HORN

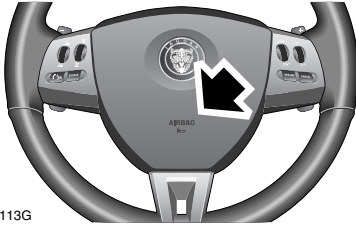

JAG0113G

The dual tone horn is operated by pressing the centre pad on the steering wheel.

The horn also operates as a warning horn if the vehicle alarm system is activated.

HEATED STEERING WHEEL

The heated steering wheel is activated via the touch-screen main **Home** screen.

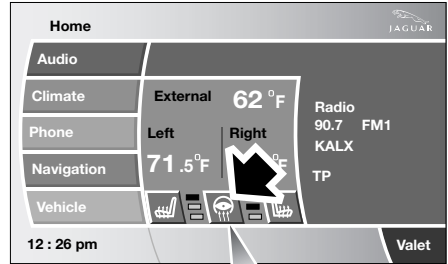

JAG0115NAS

With the engine running, press the steering wheel icon for heating either ON or OFF.



JAG0117NAS

The heated steering wheel can also be activated via the Climate Control **main** screen by pressing the steering wheel icon for heating either ON or OFF while the engine is running.

Steering Wheel

AUDIO CONTROL

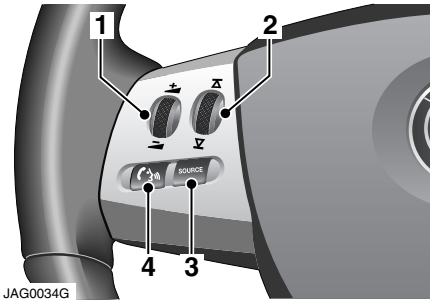

1. Increase or decrease volume.
2. Cycle through preset radio stations or next CD track. A short press will seek up or down to next preset station or next CD track. Press and hold for two seconds to select next strong radio station or next CD.
3. Cycle through radio FM, AM and CD changer. Press and hold for two seconds to select Phone Ready mode.
4. Select mute or answer phone call when ringing.

CRUISE CONTROL

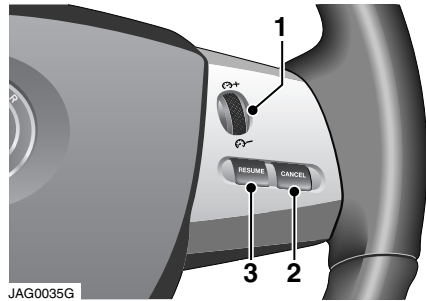

The cruise (speed) control system can be used by the driver to maintain a selected vehicle speed 40 km/h (25 mph) for 2.5- and 3.0-litre vehicles, and 28 km/h (18 mph) for 2.0-litre petrol and diesel vehicles, without the driver having to use the accelerator.

Controls on the steering wheel allow the driver manual control of the system.

1. **SPEED ADJUSTMENT CONTROL:**
The thumb wheel is used to engage cruise control initially. It is also used to increase or decrease the set speed.
2. **CANCEL:** cancels cruise control but retains the set speed in memory.
3. **RESUME:** engages cruise control after it has been cancelled.

For more information about cruise control, see page 169.

For information about adaptive cruise control, see page 173.

Wipers and Washers

WINDSHIELD WIPERS

The windshield wipers and screen wash functions are controlled by the right-hand column stalk and only operate with the ignition system ON.

Note:

- Do not operate the wipers on a dry screen.
- In freezing or very hot conditions, ensure that the blades are not stuck to the glass.
- In winter, remove any snow or ice from around the arms and blades, including the wiped area of the of the windshield and the heater air intakes. If the wiper blades have stuck to the glass, an electronic cut-out may temporarily prevent the wiper motor from operating. If this occurs, switch OFF the wiper and the ignition system. Clear the obstruction and try again.

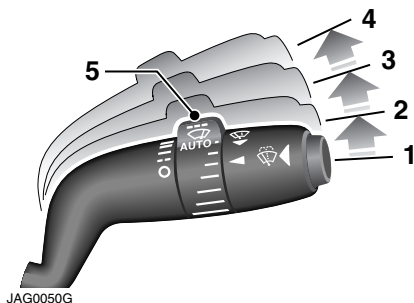

The stalk functions are as follows when placed in the shown positions:

1. Windshield wipers off and parked.
2. Intermittent wipe.
3. Normal speed wipe.
4. Fast speed wipe.
5. Intermittent wipe rotary collar.

Intermittent wipe

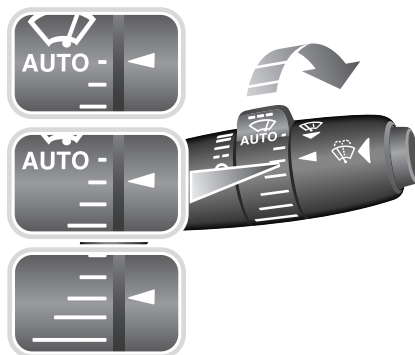

JAG0124G

When intermittent wipe **2** is selected, the delay between wipes can be varied by turning the rotary collar **5** to the required delay position. Rain sensor wiper operation is selected by turning the collar to **AUTO**.

Note: If configured, the delay period for each collar position (excluding **AUTO**), automatically increases and decreases with vehicle speed.

Flick wipe

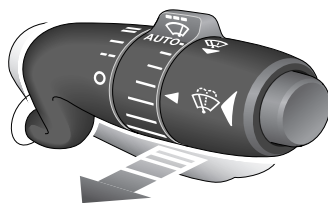

JAG0123G

Pull the stalk towards the steering wheel for a single wipe. Holding the column switch in this position will operate the wipers continuously at normal speed until released.

Wipers and Washers

Speed dependant mode

If speed dependant mode is configured, the operation of all wiper modes will be affected by the vehicle speed.

Speed dependant mode becomes active when the wipers are operating and the vehicle speed exceeds 10 km/h (6 mph). If the vehicle subsequently becomes stationary, the wiper automatically change to the next lowest operating speed. When the vehicle starts moving again, the original wiper speed setting is automatically restored.

Speed dependant mode can be configured at your Jaguar Dealer.

RAIN SENSOR

Caution:

- **Ensure that AUTO is not selected when entering a car wash or damage to the wiper blades or arms can occur as they will operate in the car wash.**
- **During frosty conditions ensure that AUTO is not selected before operating the ignition system as damage to the wiper blades can occur when the windshield is frozen.**

When **AUTO** (turn the rotary collar **5** to **AUTO**) and intermittent wipe **2** are selected, the wipers will automatically operate when rain falls on to the windshield, or when moisture is present.

For the wipers to operate, the ignition system must be in the ON position.

***Note:** When starting a journey with a wet windshield, the rain sensing wipers may not operate immediately when the ignition system is switched ON. Therefore, a flick wipe should be used to clear the windshield of any moisture.*

***Note:** Some States require headlights to be ON when wipers are in use.*

CHECKING THE WIPER BLADES

Windshield wiper blades – clean and inspect

Grease, silicone and gasoline-based products impair the blade's wiping capability.

Lift the wiper blades clear of the windshield and wipe the blades with a clean, soft cloth moistened with water to which a mild liquid detergent has been added.

If signs of hardness or cracking in the rubber are found, or if the wipers leave streaks or unwiped areas on the windshield during use, then the wiper blades should be replaced.

***Note:** The wiper arms have a restricted lift of 10 degrees.*

Use Jaguar Screen Clean Paste to remove contamination from the windshield to ensure effective wiping or if smearing or juddering becomes evident.

A more aggressive cleaning agent may be required to remove stubborn contamination. You should contact a Jaguar Dealer for advice.

Wipers and Washers

CHANGING THE WIPER BLADES

Only fit replacement wiper blades that are identical to the original specification.

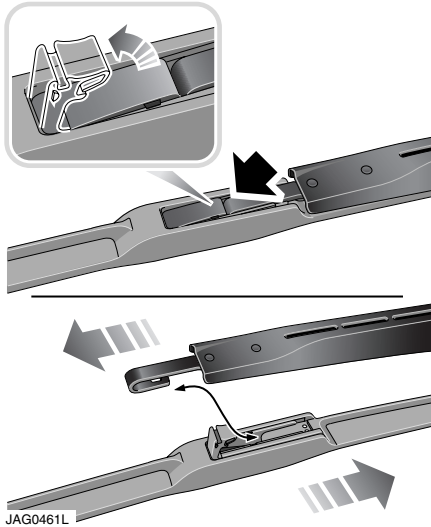

Lift the locking tab to release the blade assembly and slide the wiper assembly off the end of the wiper arm. Carefully replace the wiper arm assembly to its stowed position.

To replace the wiper blade, position the wiper arm into the aperture in the middle of the new blade assembly and fully locate the blade into the wiper arm. Push the lock tab firmly into position so that the wiper blade is locked into the wiper arm.

WINDSHIELD WASHERS

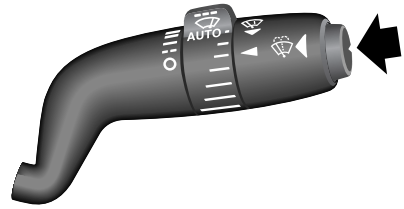

JAG0125G

Program wash and wipe

Timed jet function: If timed jet function is configured, the windshield washer jets (located on the wiper arms) only spray on the up stroke of the wiper arms. This function can be configured at your Jaguar Dealer.

With the stalk in the OFF or intermittent position, the program wash and wipe sequence is activated by pushing the button on the end of the column switch.

Short press: The wipers will perform five normal speed wipes, followed by a drip wipe. The washer jets will spray on the first two wipes.

Extended press: The wipers and washers will operate continuously at normal speed until the button is released. When released, the wipers will complete their current wipe and then complete three further wipes, followed by a drip wipe.

Drip wipe: If drip wipe is configured, following completion of the program wash and wipe cycles, the wipers will pause for four seconds then complete a drip wipe to clear any remaining drips from the windshield.

This function can be configured at your Jaguar Dealer.

Wipers and Washers

Washer

If normal or fast wipe is selected, pressing the program wash and wipe button will operate the washer jets.

- Short press: The washer jets spray for two wipes.
- Extended press: The washer jets spray until the button is released or a 10 second timer has elapsed.

Note: *If the button is pressed during the up-stroke of the wipers, the washer jets may spray for the completion of that wipe, prior to spraying for the required number of wipes or duration.*

If the rotary collar is set to **AUTO**, the wipers will operate until no moisture is detected.

Note: *If the low washer fluid warning is ON, the windshield wipers will not operate when program wash and wipe is activated even though there may be washer fluid remaining in the reservoir and sprayed onto the screen. This is to prevent damage to the blades, scratching of the glass, or smearing dirt across the screen. Flick wiper, normal or fast operation, can be selected to clear any spray from the windshield.*

HEADLAMP WASHERS

Note: *Telescopic headlamp powerwash units are contained within the front headlamp units.*

If the ignition system is in the ON position, dipped beam headlamps are switched ON and there is sufficient fluid in the washer reservoir, pressing the program wash and wipe button will also operate the headlamp powerwash; directing two short bursts of washer fluid onto the headlamps.

After the first headlight powerwash operation, the headlight powerwash will operate on every fourth press of the program wash and wipe button, provided that the headlamps are still switched ON and a 10 minute timer has elapsed since the last headlamp powerwash.

Note:

- *The powerwash sequence is reset when the headlamps or ignition is turned OFF and ON again.*
- *The headlamp powerwash function is inhibited when the low washer fluid warning is on.*

Lighting

GENERAL INFORMATION

Active front lighting system (AFL)

Active Front Lighting (AFL) is designed to give the driver improved visibility under varying driving conditions.

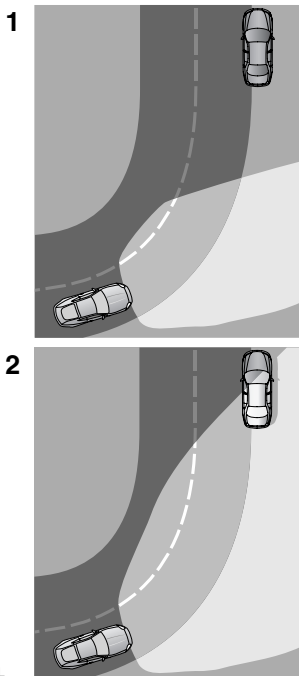

The illustration shows the light spread of a vehicle NOT FITTED with AFL **1** and a vehicle FITTED with AFL **2**.

The main light source consists of bi-functional (high and low beam) xenon projector units.

The projector units are swivelled left or right to improve the light spread on bends in the road.

Bi-Xenon lights **3** provide significantly improved visibility over halogen lights **4**.

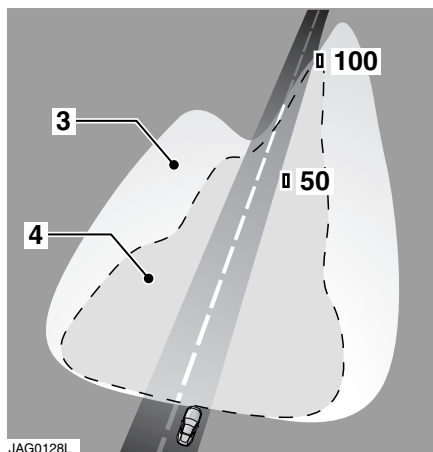

They also react dynamically in the vertical plane to the vehicle's braking or acceleration to maximise headlamp performance.

The units operate when the engine is running and the master lighting switch set to headlamps, see page 71, or **AUTO**, if the ambient light has fallen below a preset level.

The system takes inputs from the vehicle's road speed, steering angle to determine the amount of horizontal swivel. The amount of swivel is highest at low speed, manoeuvring speeds and reduces as speed increases.

If reverse gear is selected, the lamps return to the central position and the swivelling capability is disabled.

When the engine is started, the headlamps can be seen to swivel as they initiate a self-calibration cycle for a few seconds.

Lighting

Cornering or static bending lamps

Additional lighting comes from the cornering or static bending lamps which are angled outwards from the centre line of the vehicle.

These lamps broaden the beam of the headlamps when cornering during normal night driving.

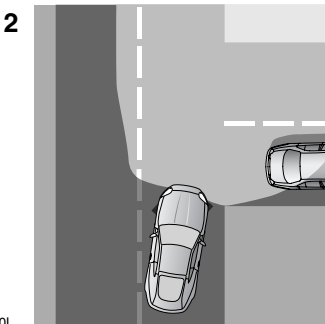
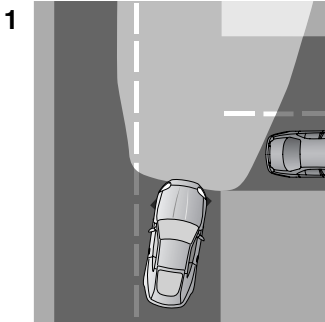

JAG0130L

The illustration shows the light spread of a vehicle NOT FITTED **1** with static bending lamps and a vehicle FITTED **2** with static bending lamps.

The system switches on the lamp if it has received an input from the vehicle's direction indicator. As the system is ignition based, the lamp will not stay on even if the vehicle is parked with the direction indicator lever in the operating position.

Only the lamp on the same side as the operating direction indicator illuminates.

Note: Excessive rotation of the steering wheel while the ignition system is in the OFF position may cause incorrect calibration of the static bending lamps. In extreme situations the lamps may operate earlier than previously experienced. However, correct calibration of the lamps is automatically re-established within 30 seconds of the vehicle being driven.

Lighting

LIGHTING CONTROL

Note: If the ignition system is OFF and the lamps are left ON, the message centre will display **LIGHTS ON**.

The exterior lamps are controlled by the left-hand column stalk switch.

The rotary collar on the stalk has three positions for turning the exterior lamps on or off and positions for autolamps and exit delay. These are:

OFF



JAG0132G

All exterior lamps OFF (except vehicles provided with daylight running lamps).

Sidelamps

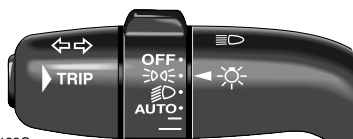

JAG0133G

Switches on front sidelamps, tail, number plate and any other marker lamps required by local legislation. When the external lamps are ON the instruments will also be lit.

Headlamps

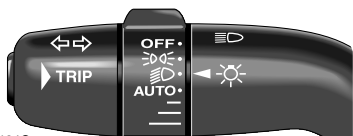

JAG0134G

With the ignition in **convenience mode**, see page 42, this position switches on low beam headlamps in addition to the lights switched on in sidelamp position.

The left-hand column stalk switch has two positions for controlling the high beam.

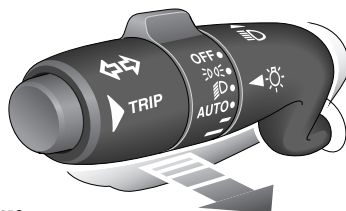

JAG0135G

Pulling the switch towards the steering wheel and releasing causes the high beam to flash on and off. The high beam can be flashed at any time when the switch is pulled and will remain ON for as long as the switch is held.

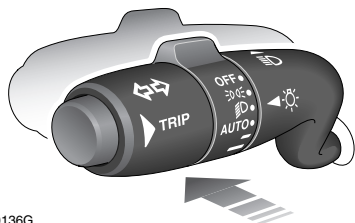

JAG0136G

The second position is to switch high beam headlamps ON. With the ignition system ON, see page 50, first select low beam lamps, and then push the column light switch away from the steering wheel.

The blue warning light on the instrument cluster and high beam headlamps will come ON.

To turn high beam OFF, pull the column switch towards the steering wheel to return to low beam.

Lighting

Note: If low beam is switched OFF, the rotary controls switch is moved, with high beam still activated, both low and high beam will be extinguished. Both low and high beam will illuminate if low beam is turned on again.

Autolamps

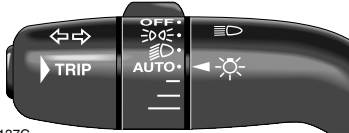

JAG0137G

A light sensor control, mounted on the front of the fascia, monitors exterior light levels and automatically switches the sidelamps and low beam headlamps ON or OFF.

The ignition system must be ON for full automatic light operation.

When light fades towards dusk, the sidelamps and headlamps will switch ON automatically.

At dawn, as light increases, the sidelamps and headlamps switch OFF automatically.

Do not cover the sensor and keep the windshield clean. Obstructing the light in this area of the sensor may lead to unwanted operation of the sidelamps and headlamps.

Windshield wiper detection

(This function only operates when autolamps is selected.) The sidelamps and headlamps will switch ON automatically if the windshield wipers are switched ON for 20 seconds or more. Once the windshield wipers are switched OFF, the sidelamps and headlamps will automatically switch OFF two minutes later.

Autolamps with Exit Delay

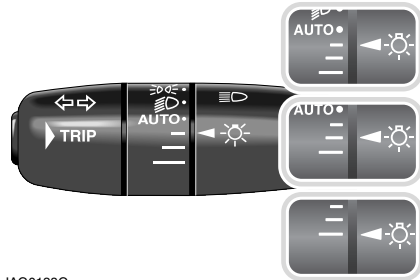

JAG0138G

Three settings on the rotary collar set the time that the headlamps will remain on after the driver's door has closed:

- 30 seconds.
- 60 seconds.
- 120 seconds.

The message centre will display the change set delay **AUTOLAMP DELAY X:XX** or **AUTOLAMP DELAY OFF** when the autolamp delay function has been turned OFF.

Note: If the light switch rotary collar is in the **AUTO** position there will be no exit delay and the headlamps will turn off when the ignition system is OFF.

Door guard and puddle lamps

Door guard lamps are fitted to each door to give warning of an open door to passing vehicles. Puddle lamps illuminate the step out area at night.

Each lamp comes on automatically when the door is opened. If the door is left open the lamps remain on for approximately 15 minutes after returning from **convenience mode** to power off.

Lighting

Daylight running lights (Canada only)

In certain countries it is a legal requirement for the lights to be on during the hours of daylight.

With the rotary collar in the OFF position, low beam headlamps, sidelamps, tail, license plate lamps and, where fitted, side marker lamps will switch on automatically with the following conditions:

- The ignition system is ON.
- The vehicle gear selector out of park.
- The parkbrake is not applied (is released).

Cabin Lighting

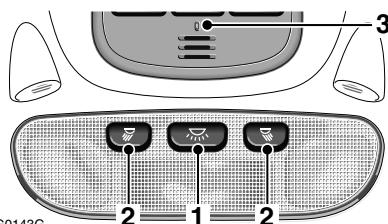

1. Courtesy light and footwell lights.
2. Left and right-hand reading and map lights.
3. Centre console illumination.

Interior lighting comprises, front overhead courtesy lights, two front reading and map lights and front puddle lights. Vanity mirrors, glove compartment, footwell and luggage compartment lights are also provided.

Press the centre switch **1** in the front roof console to turn the courtesy lights, puddle lights and footwell lights on. A second press turns the lights off. The lights also operate to illuminate the vehicle interior when a door is opened.

The interior courtesy light and footwell lights can be de-activated by pressing the centre switch for more than two seconds. The courtesy light will flash, then switch OFF.

The courtesy light and footwell light will come on again when the light switch is pressed again for more than two seconds.

The centre console area is illuminated by a small light from the overhead console **3**. This is on whenever the sidelights are on and can be controlled by the dimmer switch.

Reading lighting

The reading and map lights are turned on and off by individual switches, **2** on the front overhead console.

Illuminated entry and exit

The interior lights will gradually illuminate when a door is opened and go out when the engine is started or approximately 30 seconds after the last door is closed. If any door is left open, the lights will fade off after approximately 15 minutes after returning from **convenience mode** to power OFF.

When the vehicle is unlocked the courtesy lights will come on at maximum brightness for approximately 30 seconds if a door is not opened.

With the engine running, opening any door will put on all interior lights, they will go out immediately after the last door is closed.

Lighting

Glove compartment

The glove compartment will illuminate when opened.

Luggage compartment lighting

The luggage compartment will be illuminated when the lid is opened.

Battery saver

If the interior lights are switched on using the centre switch in the overhead console and the ignition switch is in **convenience mode**, the lights will automatically turn OFF after approximately 15 minutes after returning from **convenience mode** to power off.

If the interior lights are switched on by opening a door, the lights will automatically turn off after approximately 15 minutes after returning from **convenience mode** to power off.

If the glove compartment lights, luggage compartment lights, reading and map lights or vanity lights are switched on, and the ignition switch is in **convenience mode** or the remote handset is removed, the lights will automatically turn OFF after approximately 15 minutes after returning from **convenience mode** to power off.

DIRECTION INDICATORS

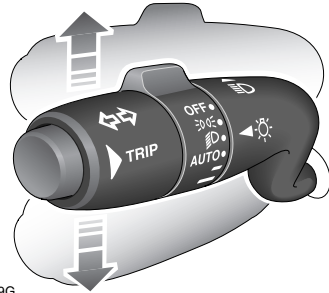

JAG0139G

The direction indicators operate when the ignition system is ON.

The left column stalk has two positions for indicating left or right turn.

The first position, moving the stalk up or down, causes the indicator to flash while it is held in this position.

Flicking the stalk will give a three flash lane changing signal.

The second position is a full movement of the stalk up or down to indicate for a right or left turn, which can then be released. The indicators will remain flashing and will cancel when the turn is completed.

An audible ticking and a flashing green arrow on the instrument cluster indicates that the selected direction indicator is ON.

Note: Should a direction indicator bulb fail, the corresponding side green warning light will flash at twice the normal rate. The audible ticking will sound at twice the normal rate.

Lane change flash

Move the left column stalk partially up or down against spring pressure, then release, to indicate a lane change. The relevant direction indicator flashes three times.

Lighting

If the stalk is held against spring pressure, the direction indicators will continue to operate until the stalk is released.

Lane change flash can be disabled or enabled by a Jaguar Dealer.

FRONT FOG LAMPS

The fog lamps can only be switched on when the ignition system is ON and when sidelamp or low beam is selected.

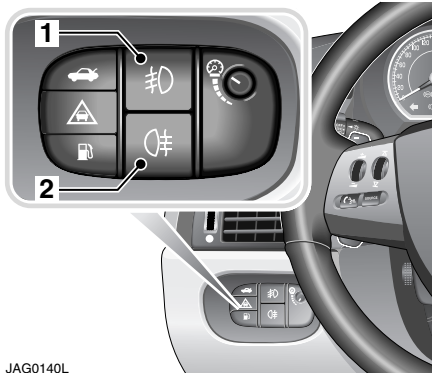

JAG0140L

With the lighting control switch in sidelamp or low beam position, press the switch **1** to turn on the front fog lamps. Pushing the switch again will turn off the front fog lamps.

Note: The front fog lamps should only be used when visibility is severely restricted by fog.

REAR FOG LAMP

The rear fog lamp can only be switched on if the low beam headlamps are on or if the sidelamps and front fog lamps are switched on.

Press the switch **2** to turn on the rear fog lamp. Pushing the switch again will turn off the rear fog lamp.

Note:

- Both front and rear fog lamps will be turned off when the ignition system is turned off, but will not be illuminated when the ignition system is turned on again.
- The rear fog lamp should only be used when visibility is severely restricted by fog.

Lighting

HAZARD WARNING FLASHERS

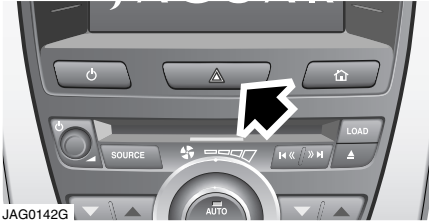

JAG0142G

The switch is in the centre console below the touch-screen and operates with the ignition ON or OFF. Use only in an emergency to warn traffic of a vehicle breakdown or approaching danger.

To operate: Press the switch; the direction indicators, the instrument cluster green indicators and audible warning will operate in unison. The switch icon will flash in unison with the indicators.

To cancel: Press the switch again.

HEADLAMP LEVELLING

Auto headlight levelling

Automatic levelling of the headlamps is a feature which avoids dazzling oncoming drivers. A control unit adjusts the aim of the lamps during acceleration, deceleration and vehicle load conditions.

ADJUSTING THE HEADLAMPS

When touring in right-hand traffic countries, use the beam adjustment mechanism located within each headlamp unit to alter the beam pattern accordingly.

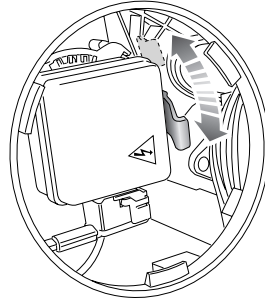

JAG0144G

When this is moved it enables the vehicle to be driven in opposite hand drive markets without having to stick blanking decals onto the headlamp lens.

To adjust the headlamp:

1. Remove the headlamp unit, see page 78.
2. Twist anticlockwise and lift off the rear headlamp unit cover.
3. Locate the adjustment lever, as shown.
4. Move the lever fully **downwards**.
5. Refit the high beam cover and the headlamp unit, see page 79.

Remember to place the levers back in their original position when you have returned to your country of origin.

Lighting

CHANGING A BULB

It is important that only the Jaguar specified bulbs are used when renewing bulbs.

The message centre will display a message indicating which bulb requires to be replaced.

Before renewing bulbs, switch off the ignition system and light switches.

To change the bulbs within the headlamp and taillamp, the complete units require to be removed from the vehicle.

Note: *In most countries it is illegal to use a vehicle with a defective exterior lamp bulb.*

Headlight unit



WARNING:

- Replacement or maintenance of Xenon lights should be carried out only by a Jaguar Dealer.
- Used Xenon lamp units contain mercury which is hazardous and can be injurious to health.
- Bi-Xenon lamp units operate at a high temperature. If they have recently been in use, allow sufficient time for them to cool down before touching them.
- The Xenon system generates up to 28,000 volts and contact with this voltage could lead to a fatality. Ensure that headlamps are switched off before working on the system.

Caution: Seek advice about proper disposal of Bi-Xenon lamp units from your Jaguar Dealer or your local authority.

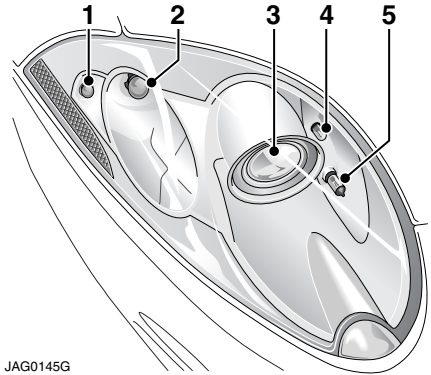

1. Side marker (bulb type WY5W).
2. Direction indicator (bulb type, front 3457AK, rear PY21Silver Vision).
3. Low and high beam projector unit (bulb type D1S35W).
4. Sidelamp (bulb type W5W).
5. Cornering lamp (bulb type H8).

Lighting

Removal of the headlamp unit

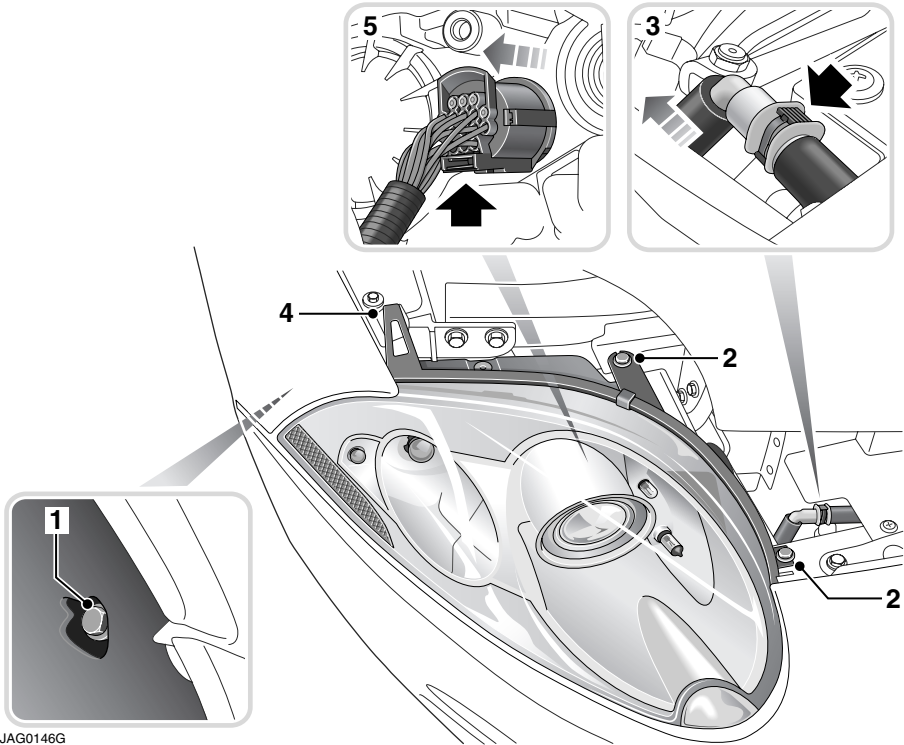

JAG0146G

1. Remove the lower headlamp securing bolt **1** located in the front of the wheel arch. Turn the steering wheel to the left, when removing the right-hand headlamp and to the right when removing the left-hand headlamp.
2. Open the hood and remove the upper securing bolts **2**.
3. Disconnect the headlamp powerwash connector by pressing the button and pulling the pipe apart **3**, some washer fluid may drain from the pipe when it is disconnected.
4. Release the headlamp locating peg by lifting the tongue upwards **4**.
5. Carefully ease the headlamp unit forward to gain access to the wiring multi-plug connector. Release the connector by pressing upwards on the release button and pull the wiring multi-plug from the headlamp **5**. Place the headlamp unit on a flat surface covered in a soft material to prevent damage to the unit's lens.

Lighting

Refitting the headlamp unit

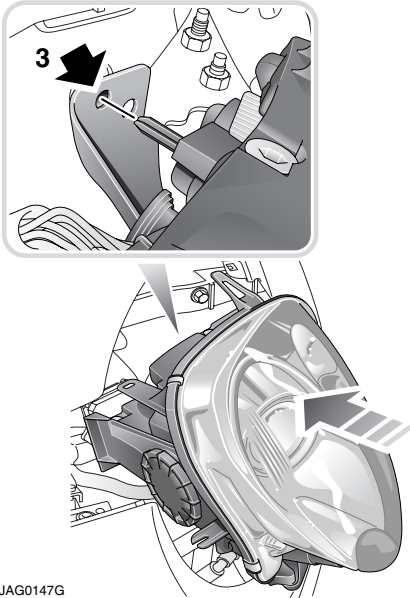

JAG0147G

1. Reconnect the wiring multi-plug connector.
2. Offer up the unit into position.
3. Ensure that the locating peg is fitted into the in-board locating hole.
4. To secure the headlamp unit, first secure the wheel arch screw, then repeat the removal procedure in the reverse order, ensuring that the powerwash pipe is reconnected.

Note: After the replacement of any bulb and the fitting of the headlamp unit, the aim of the headlamps should be checked by a Jaguar Dealer.

Front side marker lamp

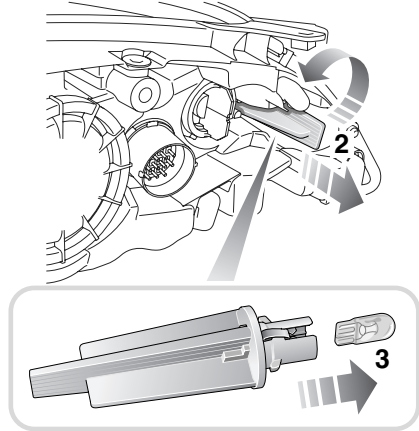

JAG0148G

1. Remove the headlamp unit, see page 78.
2. Twist the bulb holder counter clockwise and pull out the bulb complete with the bulb holder.
3. Pull the bulb out of the bulb holder.
4. Insert the new bulb (WY5W) and repeat the above procedure in reverse order.

Lighting

Front direction indicator lamp

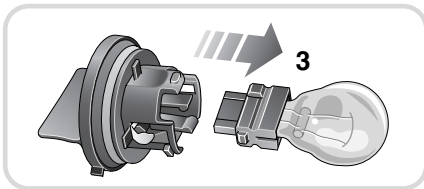
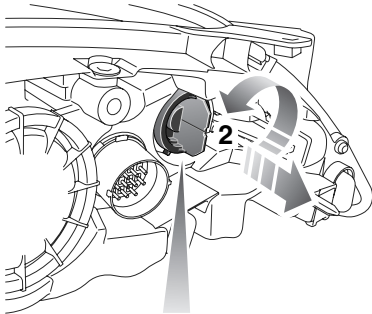

JAG0122N

1. Remove the headlamp unit, see page 78.
2. Twist the bulb holder counter clockwise and pull out the bulb complete with the electrical connector.
3. Pull the bulb out of the bulb holder.
4. Insert the new bulb (3457AK) and repeat the above procedure in reverse order.

Front sidelamp

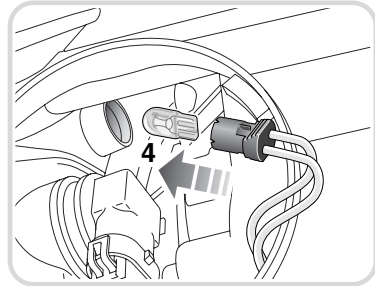
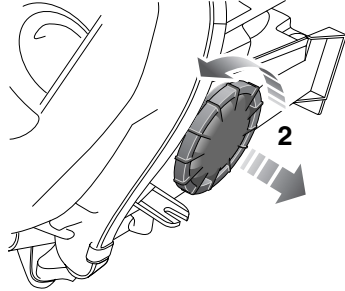

JAG0150G

1. Remove the headlamp unit, see page 78.
2. Twist and lift off the side domed cap.
3. Pull out the bulb complete with bulb holder.
4. Pull the bulb out of the bulb holder.
5. Insert the new bulb (W5W) and repeat the above procedure in the reverse order. Ensure that the cover is fitted correctly to retain the water tightness.

Lighting

Dip and main beam projector unit

Caution: It is strongly advised that the High Intensity Discharge (HID) Xenon low and high beam projector unit (D1S35W) is replaced by a Jaguar Dealer.

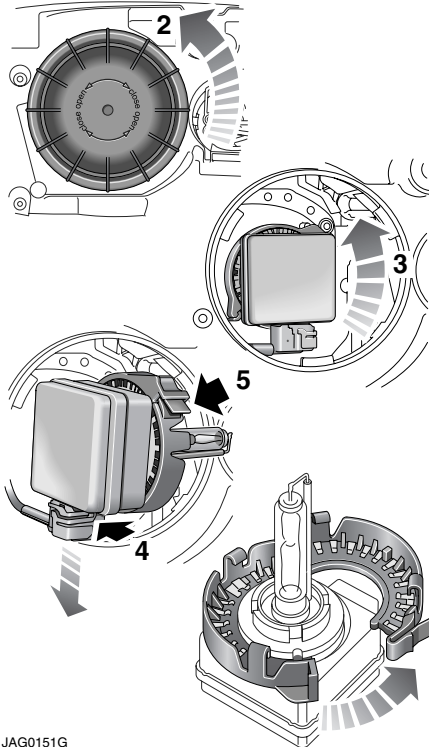

JAG0151G

1. Remove the headlamp unit, see page 78.
2. Twist and lift off the rear domed cap.
3. Twist the bulb unit counter clockwise to unlock it. Pull the bulb unit clear of the headlamp unit.
4. Press the electrical connector release lever and disconnect the bulb unit.
5. Press the bulb unit adaptor ring catch and remove the adaptor ring from the bulb unit.
6. Secure the bulb unit adaptor ring onto the new bulb (D1S35W) and repeat the above procedure in the reverse order. Ensure that the cover is fitted correctly to retain the water tightness.

Lighting

Cornering or static bending lamp

Caution: Halogen bulbs will be damaged if touched by hand or contaminated with oil or grease. It is important to use clean gloves or lint free cloth when handling a bulb which is to be used again. A contaminated bulb may be cleaned with methylated spirit before refitting.

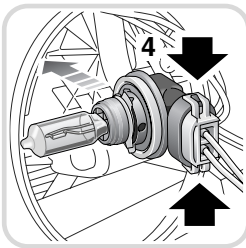
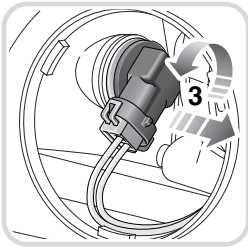
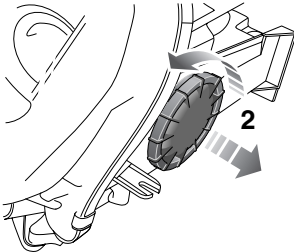

JAG0152G

1. Remove the headlamp unit, see page 78.
2. Twist and lift off the side domed cap.

3. Twist the bulb holder counter clockwise to unlock, then pull out the bulb complete with electrical connector.
4. To release the bulb unit, lift the two catches of the electrical connector, then pull to remove the bulb unit.
5. Insert the new bulb unit (H8) and repeat the above procedure in the reverse order. Ensure that the cover is fitted correctly to retain the water tightness.

Front fog lamp

It is recommended that the front fog lamp bulb is renewed by a Jaguar Dealer.

Rear fog and reverse lamps



WARNING:

LED lamp units operate at a high temperature. If they have recently been in use, allow sufficient time for them to cool down before touching them.

These lamps are LED units and are integral to the luggage compartment lid. They should only be replaced by a Jaguar Dealer.

Lighting

License plate lamp

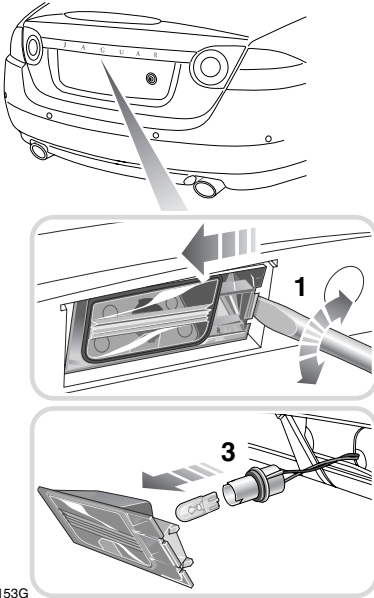

1. Insert a wide flat bladed suitable tool, twist and lever the lens out of the surround panel. Ensure that the lens moves to the outer edge of the surround panel to release the securing tangs.
2. Twist and pull out the bulb holder complete with bulb.
3. Pull the bulb out of the bulb holder.
4. Insert the new bulb (W5WL).
5. Refit the lens by locating the outboard securing tangs first and then pressing it firmly into the recess until it clicks.

Side repeater indicator

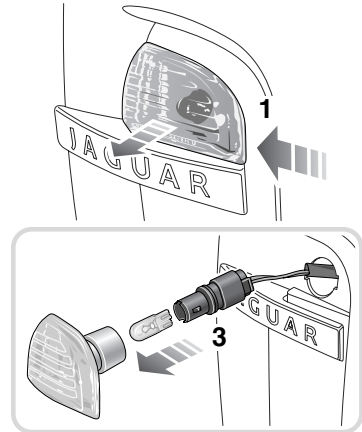

1. Push the lens firmly towards the rear of the vehicle and withdraw the light unit from the wing panel.
2. Twist to release the bulb holder from the lens unit.
3. Pull the bulb out of the bulb holder.
4. Insert the new bulb (WY5W) and repeat the above procedure in the reverse order.

Lighting

Removal of the rear lamp unit

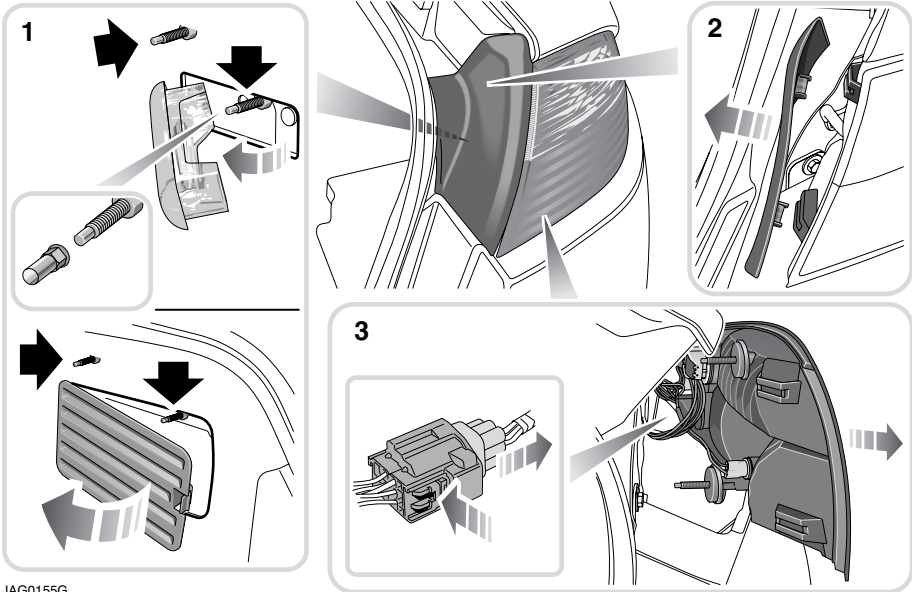

JAG0155G

The rear lamp unit contains four lamp bulbs and it is necessary to remove the unit from the vehicle in order to change any of the bulbs.

1. Open the luggage compartment. For the right-hand side unit, detach the interior light unit from the trim panel (Convertible) or the vent trim panel (Coupe) and remove the two rear lamp unit securing nuts. For the left-hand side unit, detach the vent trim panel and remove the rear lamp unit securing nut.
2. Firmly pull the rear lamp unit trim panel from the vehicle.
3. Firmly pull the rear lamp unit away from the vehicle and disconnect the wiring multi-plug connector. Remove the lamp unit from the vehicle and place the unit on a flat surface covered in a soft material to prevent damage to the unit's lens. Each bulb is now accessible by twisting off its bulb holder and removing the bulb, see page 85.
4. Insert a new bulb and repeat the above procedure in the reverse order.

Lighting

Rear lamp unit replacement bulbs

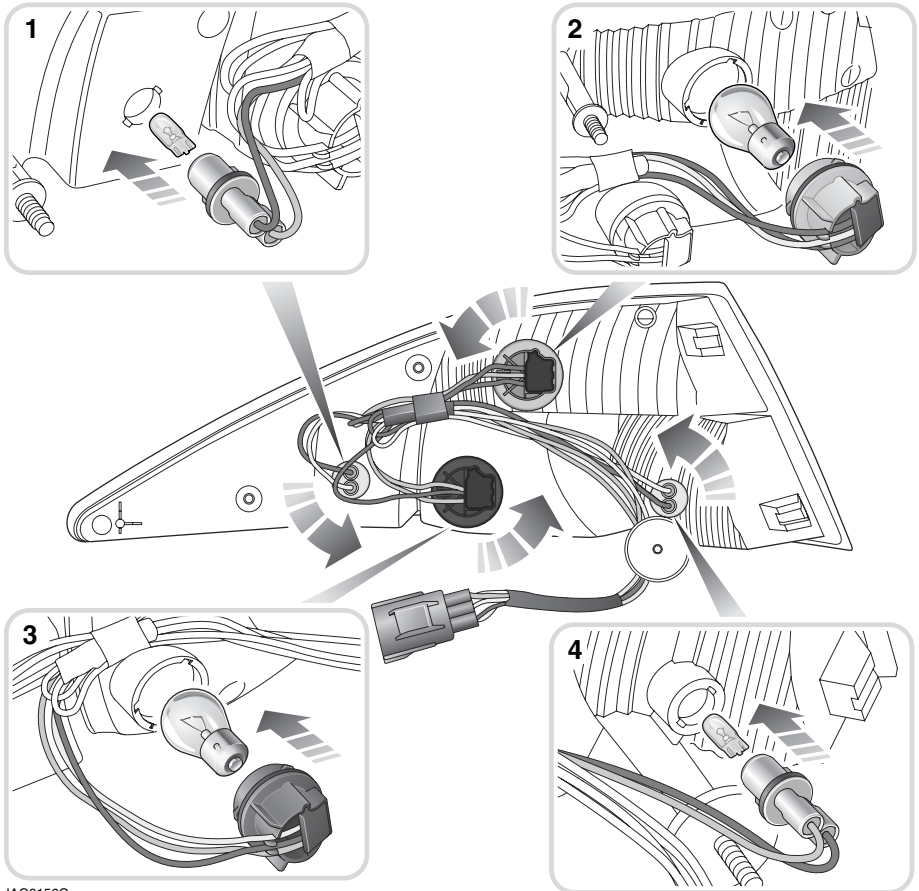

JAG0156G

1. Side marker, (W5W).
2. Direction indicator, (PY21W Silver Vision).
3. Stop and Tail, (P21/5W).
4. Tail, (W5W).

Windows and Mirrors

ELECTRIC WINDOWS

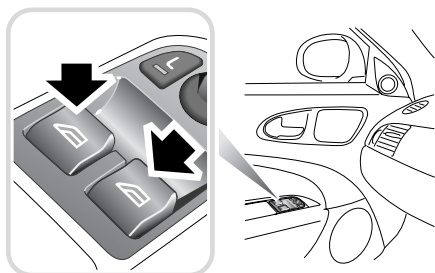

JAG0160L



WARNING:

- **Before operating power windows you should verify they are free of obstructions and ensure that children and or pets are not in the proximity of window openings. Failure to do so could result in serious personal injury. It is the primary responsibility of the supervising adults to never leave a child unattended in a vehicle.**
- **When raising windows ensure all occupants are clear.**
- **When leaving the vehicle take the ignition keys to prevent misuse of the window switches by remaining occupants, especially children.**

Switches on the driver's door controls both the driver and passenger door windows.

The passenger door is provided with a switch to control that door window only.

The ignition system must be ON to operate the windows.

These switches will only operate the windows for five minutes when the ignition switch remains in the **convenience mode** position and the driver's and passenger's doors remain closed.

Raise and lower

To lower a window, press and hold the front of the switch until the desired position is reached, then release.

To raise a window, pull up and hold the front of the switch until the desired position is reached, then release.

If the switches are held for longer than six seconds, for example, when attempting to overcome frozen or jammed windows, the window drive will be switched off for a few seconds to protect the window drive motors.

One-touch operation

Each window has a one-touch facility enabling the occupant to fully open or close the window in one quick movement.

Press the switch briefly to close or open the window in one movement. Window travel can be stopped at any time by pressing the switch again, but will then be controlled by pressing and holding the switch.

Automatic window drop for door opening

The frameless door windows create a seal against the convertible top or the roof seals. If fully raised, the door windows will drop partially when the door release lever is operated, this is to allow easy door opening. When the door is closed the windows rise to the fully closed position.

Windows and Mirrors

The doors must not be opened if power for automatic window drop is not available, e.g. with battery disconnected. However, in an emergency the doors can be opened with the windows fully up.

Window anti-trap protection



WARNING:

- **Careless closing of the windows can override the protection function and cause injuries.**
- **If the battery is disconnected or discharged the window anti-trap protection feature is lost. When the battery is reconnected or recharged the window anti-trap protection system must be reset.**

Each electrically operated window has a anti-trap protection feature. If the upward movement of the window detects an obstacle the anti-trap detection system will immediately stop the window closing, then move it downwards for a short distance.

Anti-trap protection override



WARNING:

While the window is being closed for the third time, the anti-trap detection function is disabled. Make sure there are no obstacles in the way of the closing window.

The anti-trap protection will also stop the window closing if a blockage or resistance occurs e.g. in the window guide channels.

Typically this might be due to icing in winter but could also be caused by damage or misalignment of the guide channels or seals.

- After the initial attempt to close the window and the anti-trap detection has initiated, operate the close switch a second time. This action must be carried out within ten seconds.
- The window will attempt to close again and operate the anti-trap detection. The window will now close again for the third time, but will only operate by pressing and holding the switch with the anti-trap detection disabled. The window will now close with full power. The icing in the seal can now be broken and dispersed.
- Repeat the override action until the window has closed. Each time the window stops, the switch must be operated immediately to initiate further override action.

If this procedure fails to move the blockage, the anti-trap detection feature will be lost and must be reset after the blockage has been cleared.

Reset window anti-trap protection

Ensure that the respective door is closed and, if fitted, the convertible roof closed.

- Fully close the window, then release the switch. Again pull the switch to close the window and hold for two seconds.
- Open the window fully and release the switch. Again press the switch to open the window and hold for two seconds.

Windows and Mirrors

- Check to confirm the operation by opening the window and then use one touch operation to close the window.
- Repeat for the remaining electrically operated windows.

Thermal overload

If the windows are repeatedly opened and closed (e.g. by a child), a protection system will de-activate window operation for a short period to avoid overheating of the window motors.

Caution: Do not close the door with the windows fully up as damage to the seals and the glass will occur.

Rear quarter window operation (Convertible only)

The rear quarter windows operate automatically in conjunction with convertible roof opening or closing.

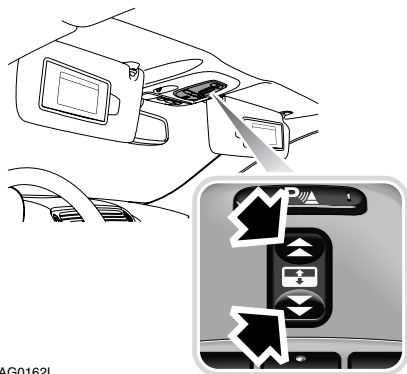

JAG0162L

The rear quarter windows may also be operated independently of the convertible roof when the convertible roof is closed, by means of the convertible roof switch on the overhead console, as follows:

To lower: Press the rear of the switch for less than a second and the rear quarter windows will be driven down fully.

To raise: Press the front of the switch and hold and the rear quarter windows will rise for as long as the switch is held.

Notes on rear quarter window operation:

1. When the convertible roof is opened the rear quarter windows are automatically lowered and cannot be operated until the roof is closed. When the roof is closed the rear quarter windows are automatically raised.
2. The rear quarter windows operate together and cannot be operated individually.

WINDOW TINTING

Caution: Do not have your vehicle windows tinted with a metal oxide tinting (for maximum heat reduction from the sun) if you have a telephone or navigation system fitted to your vehicle.

Metal oxide tinting prevents the reception of the Global Positioning System (GPS) signals by the antenna, causing the navigation system to stop functioning.

A nonmetal tinting should be used if you require window tinting and if in doubt, contact your Jaguar Dealer for advice.

Windows and Mirrors

ELECTRIC EXTERIOR MIRRORS

Caution: The right-hand mirror is convex, providing a wider field of vision. As a result, objects viewed in the mirror are closer than they appear.

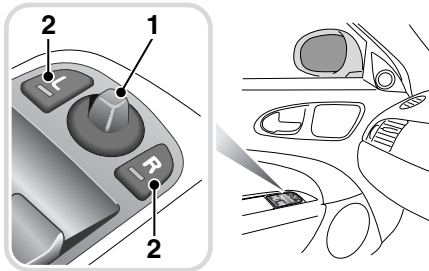

JAG0041L

Both electrochromic door mirrors are adjusted from the driver's door switchpack.

The four-way adjustment button **1** moves the mirrors to the required position. The selector button **2** selects the mirror to be moved, **L** for the left-hand side mirror and **R** for the right-hand side mirror.

The mirror housings are designed to pivot against the vehicle upon impact.

Caution: If door mirrors have been folded against the vehicle due to an impact, reposition the mirrors manually.

Mirror heating

Caution: Do not use a scraper to remove ice from the mirrors as this will damage the surface.

The door mirrors have heating elements which operate automatically based on the external ambient temperature of the vehicle. The mirror heater will clear all ice from the mirror surface.

Mirror dip when reversing

Reverse mirror dipping is selected via the touch-screen.

From the main **Home** touch-screen menu, select **Vehicle**:

- Select **Veh. settings**.
- The **Security** button is selected automatically as the default.

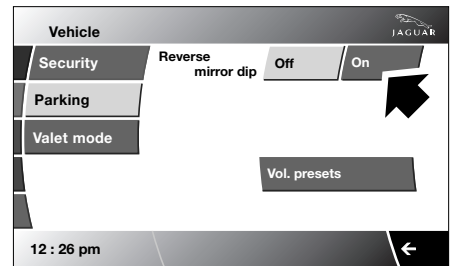

JAG0165NAS

- Select **Parking**.
- Select **Reverse mirror dip ON**.

When reverse gear is selected, the passenger mirror inclines downwards to provide a close up view of the rear side area. When the gear selector is moved out of reverse, the mirror will return to its original position.

Windows and Mirrors

The reverse mirror dip alignment can be adjusted by using the four-way adjustment button **1** when the mirror has completed movement to its reverse dip position. This new selected position is maintained until re-adjusted

Note: When reversing, if a speed of greater than 7 km/h (4 mph) is achieved, then the mirrors will revert to the previous position. However, if the speed is then reduced to below 7 km/h (4 mph), then the mirrors will revert to the dipped position.

- *The automatic darkening of the mirror will not operate properly if the light that would otherwise strike the mirror is obstructed.*

INTERIOR MIRROR

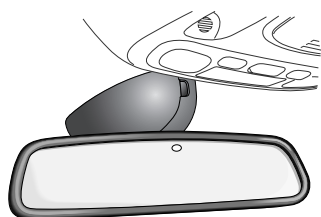

JAG0168L

During night time driving with the ignition switched on, the interior mirror will darken automatically in proportion to the amount of glare detected from a following vehicle's headlights.

When you shift the gear selector lever into reverse, the interior mirror dimming feature will be automatically switched off for a clearer view whilst reversing.

Note:

- *Should a mirror assembly become detached from the windshield, it must be refitted by a Jaguar Dealer.*
- *Ensure that the windshield in front of the mirror is kept clean. Where fitted, the moisture sensor for wiper operation is located to the front of the mirror casing. Any dirt may affect the operation of this sensor.*

Occupant Protection

FASTENING THE SEAT BELTS



WARNING:

- **Seat belts are life saving equipment. In a collision, occupants not wearing a seat belt can be thrown around inside, or possibly thrown out of the vehicle. This is likely to result in more serious injuries than would have been the case had a seat belt been properly worn. It may even result in loss of life.**
 - **Make sure all occupants are securely strapped in at all times - even for the shortest journeys.**
 - **Belts should not be worn with the straps twisted.**
 - **Always ensure that the webbing is midway between the neck and the edge of the shoulder.**
 - **Each seat belt assembly must only be used by one occupant; it is dangerous to put a belt around a child being carried on the occupant's lap.**
 - **Do not try to put an adult seat belt around two children.**
 - **Seat belts are designed to bear upon the bony structure of the body and should be worn low across the front of the pelvis or the pelvis, chest and shoulders, as applicable; wearing the lap section of the belt across the abdominal area must be avoided.**
 - **Seat belts should be adjusted as firmly as possible, consistent with comfort, to provide the protection**
- for which they have been designed. A slack belt will greatly reduce the protection afforded to the wearer.
- **Care should be taken to avoid contamination of the webbing with polishes, oils and chemicals, and particularly battery acid. Cleaning may safely be carried out using mild soap and water. The belt should be replaced if webbing becomes frayed, contaminated or damaged.**
 - **It is essential to replace the entire assembly after it has been worn in a severe impact even if damage to the assembly is not obvious.**
 - **No modifications or additions should be made by the user which will either prevent the seat belt adjusting devices from operating to remove slack, or prevent the seat belt assembly from being adjusted to remove slack.**
 - **Should the seat belt not retract and remain at its static length, you should consult your nearest Jaguar Dealer immediately.**
 - **Replacement and renewal of seat belts should be carried out by Jaguar Dealers only.**

The use of front and rear seat belts is mandatory in most countries. Using seat belts saves lives.

Occupant Protection

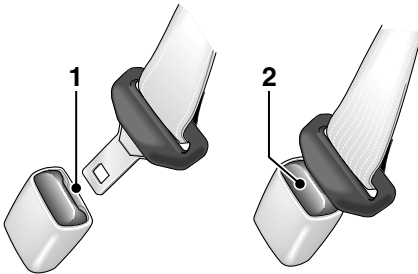

JAG0173G



WARNING:

Do not adjust the seat belt while driving.

Draw the tongue of the seat belt over the shoulder, across the chest and push it into the buckle unit slot **1**. A positive click indicates that it is safely locked.

The use of comfort clips or devices that would create slackness in the seat belt system is not advised.

Ensure that the webbing is midway between the neck and the edge of the shoulder. Correct tension is controlled by automatic retraction of the reel.

Always wear seat belts without slack or twists, since any slack in a seat belt reduces the effectiveness of the belt and the level of protection it can provide. For optimum protection, the seat belts should fit tightly around the body. Do not recline the front seats excessively. Optimum benefit is obtained from the seat belt with the seat back angle set to no more than 30 degrees from the upright.

Note: If the vehicle is parked on unlevel ground, the seat belt mechanism may lock. This is not a fault, allow the seat belt to retract a small amount before gently easing the belt from its attachment to unlock it.

Belt buckle release

To release the belt buckle, press the release button **2** in the buckle unit and guide the belt back up to the seat mounted webbing guide.

Front occupants only: The front seat belts are equipped with an automatic webbing tension relieving device. This device will reduce the webbing loads experienced by the occupant when the seat belt is correctly worn without inducing any slack webbing.

The device is activated when, with the ignition system ON and the seat belt tongue engaged in the buckle, webbing is extracted on occupant lean forward (a series of clicks indicate the range of movement with reduced tension).

If the engine is turned off with the seat belts still fastened, a slight increase in seat belt tension may be felt. This is normal, it is part of the seat belt assembly's tension control device.

Front passenger seat belt -belt tensioner sensor (Canada and USA only)

The front passenger seat belt is fitted with a belt tension sensor which is part of the occupant classification sensor system, for further information see page 96.

Occupant Protection

Seat belt guide and retainer

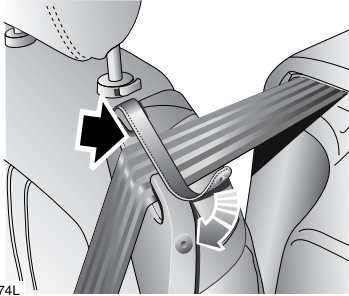

To assist with both access and positioning of the front seat belt webbing, a guide-retainer is incorporated into each front seat.

When the front seat back is tilted forward to gain access to the rear of the vehicle it is recommended that the seat belt is removed from the guide.

On returning the front seat back to the upright position ensure that the seat belt is returned to the seat belt guide.

Inertia reel mechanism test

- With the seat belt fastened, give the webbing near the buckle a quick upward pull. The buckle must remain securely locked.
- With the seat belt unfastened, unreel the webbing to the limit of its travel. Check that the unreeling is free from snatches and snags and then allow the belt to fully retract.
- Partially unreel the webbing, then hold the tongue plate and give it a quick forward pull. The mechanism must lock automatically and prevent any further unreeling.

If a seat belt should fail any of these tests, contact your Jaguar Dealer.

SEAT BELT REMINDER

The belt reminder feature provides additional reminder to the driver that an occupant's seat belt is unbuckled. A chime will sound intermittently.

Note: *Not all countries have the warning chime.*

Seat belt warning



A warning indicator on the instrument panel is illuminated when:

- The driver's seat belt is not fastened.
- A passenger is sitting in the front seat and their seat belt is not fastened.

In some countries a warning signal sounds for six seconds.

Occupant Protection

USING SEAT BELTS DURING PREGNANCY

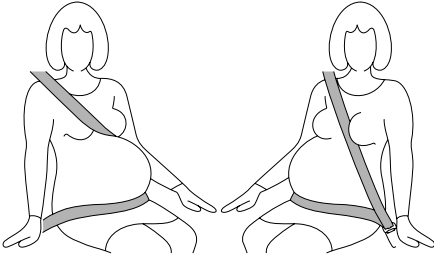

JAG0176G



WARNING:

Position the seat belt correctly for the mother and unborn child. Never wear just the lap strap and never sit on the lap strap while using just the shoulder strap. Both of these actions are extremely dangerous and may increase your risk of serious injury in the event of an accident.

Position the lap strap comfortably across the hips and low beneath the pregnant abdomen. Place the diagonal part of the seat belt between the breasts, above and to the side of the pregnant abdomen. Always wear a seat belt without slack or twists.

Occupant Protection

OCCUPANT SENSING



WARNING:

- **No objects whatsoever should be attached to the centre cover of the steering wheel, the passenger fascia panel, the sides of the front seats or the interior trim immediately above the door openings. Do not put anything on or over the air bag inflation area. Placing objects on or over the air bag inflation area may cause those objects to be propelled inside the vehicle causing serious injury to the occupants.**
- **Occupants with disabilities that may require the vehicle to be modified must contact a Jaguar Dealer before any modifications are made.**

***Note:** (USA only) If you are considering modifying your vehicle in any way to accommodate a disability, for example by altering or adapting the driver's or passenger's seat(s) or air bag system, please contact Jaguar Cars at:*

Jaguar Cars

Customer Relations Center

555 MacArthur Blvd

Mahwah

New Jersey 07430-2327

1-800-4JAGUAR OPTIONS 9.

- **Several air bag system components get hot after inflation. Do not touch them after they have deployed.**

- **If an air bag has inflated, the air bag will not function again and must be renewed immediately. If a new air bag is not fitted, the unrepaired area will increase the risk of injury in a collision.**

In order to provide optimum protection this vehicle is equipped with front and side air bags. They are used in conjunction with the seat belts to help protect occupants from upper body (thorax) and head injuries.

Occupant Protection

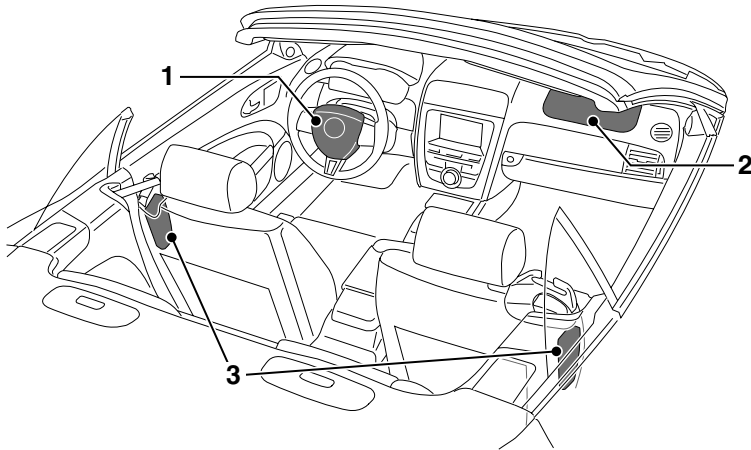

JAG0177L

Air bag location

1. Driver's air bag.
2. Front passenger air bag.
3. Combined head and thorax side air bags are identified by labels.

System sensors

The air bags and seat belt pretensioners are electrically controlled by an Advanced Restraints Technology System (ARTS).

Various sensors determine the direction and severity of an impact. The system analyses this information then deploys only the appropriate air bags e.g. the side air bags where the impact is on that side only.

are not designed to deploy at very low speeds or in rear impacts.

Occupancy classification sensor

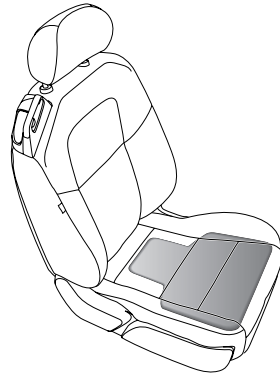

JAG0512L

A weight sensitive sensor is located in the front passenger seat to determine the weight acting upon the seat. In certain conditions, e.g. where no passenger is present, the appropriate will be deactivated. In a collision these would not be deployed.

Occupant Protection

The occupancy weight sensor operates as follows:

Passenger occupancy status	Passenger air bag status	Indicator active
Completely empty	Deactivated	No*
Low weight occupant/object	Deactivated	Yes
Heavy occupant/object	Activated	No
Child restraint fitted **	Deactivated	Yes

*It is possible to receive an intermittent indicator illuminated with an empty seat condition. This is part of the system's adaptive behaviour, and does not affect the status of the passenger air bag. However, if the indicator becomes permanently illuminated when the seat is definitely empty and the seat belt is unbuckled, then contact your nearest Jaguar Dealer immediately.

- If the seat is empty and the seat belt unbuckled, the front passenger air bag will not be activated and the air bag indicator will not be illuminated.
- If the seat is occupied by, for example, a small child or object with the seat belt buckled, the front passenger air bag will not be activated and the air bag indicator will be illuminated.

- If the seat is occupied by a larger child or adult, the front passenger air bag will be activated and the air bag indicator will not be illuminated.
- **** (Canada and USA only)** Belt tension sensor (BTS): If a child restraint is fitted in the front passenger seat using the seat belt's automatic locking device (see page 105), then the BTS supports the decision function of the occupant classification sensor and the front passenger air bag is deactivated.

Note: *The occupancy sensing system is designed to confirm that a front passenger is properly seated as recommended:*

- *Always sit centrally in the seat, remaining in contact with the seat back which for comfort should be rearwards of the vertical position.*
- *Adjust the seat to be as far back from the fascia as is practical.*
- *Always wear seat belts.*

The seat adjustment controls are described on page 57.

Occupant Protection

Air bag deactivation indicator



JAG0516N

The air bag indicator, on the centre console is associated with the deployment conditions for front seat passenger air bags only.

Whenever the air bag indicator is illuminated, the front passenger air bags will not be deployed in the event of an impact. Where the air bags are not deployed, protection is provided by the seat belts.

Note: The air bag indicator will illuminate when the ignition system initially comes on as part of the warning lamp check and will extinguish after approximately six seconds.

Overall system components

The overall occupant protection system, Advanced Restraint Technology System (ARTS) comprises the following components:

1. Dual front crash sensors.
2. Passenger dual stage air bag.
3. Passenger buckle pretensioner.
4. Passenger seat occupancy sensor.
5. Passenger belt tension sensor.
6. Passenger side head and thorax air bag.

7. Passenger side crash sensor.
8. Right-hand rollover protection bar (convertible only).
9. Left-hand rollover protection bar (convertible only).
10. Restraint control module.
11. Driver side crash sensor.
12. Driver side head and thorax air bag.
13. Driver buckle pretensioner.
14. Driver dual stage air bag (steering wheel).

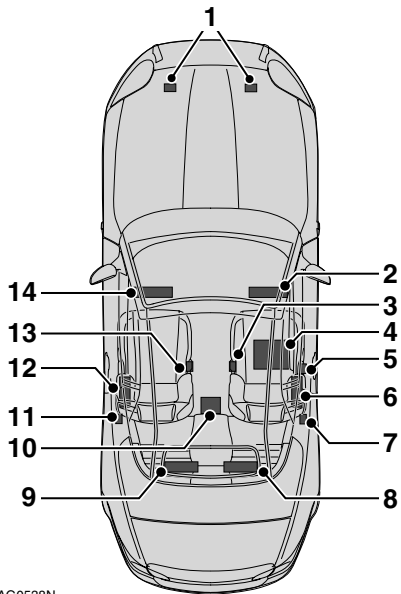

JAG0538N

Occupant Protection

AIR BAG LABELS

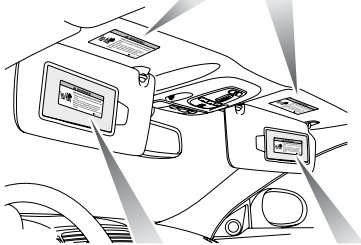

JAG0540N

An alert label on the front face of the driver's and passenger's sun visor directs you to read the warning label on the rear face of each sun visor.

The warning label contains the following statement:



WARNING:

EVEN WITH ADVANCED AIR BAGS

- Children can be killed or seriously injured by the air bag.
- The back seat is the safest place for children.
- Never put a rear-facing child seat in the front.
- Always use seat belts and child restraints.

- See Owners Manual for more information about air bags.

DRIVER AIR BAG



WARNING:

The air bag is a supplementary restraint system that provides additional protection in a severe impact only - it does not replace the need to wear seat belts. For maximum safety protection in all crash situations, a seat belt must be worn.

Note: Provided front seat occupants are correctly seated, with seat belts worn, the air bag will give additional protection to the chest and facial areas in the event of an accident.

Both front air bags use a dual inflation technology which means, if activated, the air bags will deploy as appropriate for the severity of frontal impact.

Air bag deployment



WARNING:

Activation of an air bag creates dust, causing possible breathing difficulties for asthma sufferers or other people with respiratory problems. If an air bag is activated, any occupant who suffers from breathing difficulties should; either leave the vehicle as quickly as possible, or obtain fresh air by fully opening the windows and doors.

Following inflation, some air bag components are hot - do not touch until they have cooled.

Occupant Protection

Even with air bag equipment fitted, seat belts must always be worn because:

- **An air bag will only provide additional protection in certain types of frontal collision. No protection is afforded against the effects of rear impacts, or minor frontal impacts.**
- **Inflation and deflation takes place instantaneously and will not provide protection against the effects of secondary impacts that can occur during multiple vehicle collisions.**
- **An inflating air bag can cause facial abrasions and other injuries. Minimise the risk of injury by ensuring that front seat occupants are wearing their seat belts and are seated correctly, with the seat as far back as is practical.**

When an air bag inflates, a fine powder is released. This is not an indication of a malfunction. However, the powder may cause irritation to the skin and should be thoroughly flushed from the eyes and any cuts or abrasions of the skin. After inflation, front and side air bags deflate immediately (head air bags deflate slowly). This provides a gradual cushioning effect for the occupants and also ensures that the driver's forward vision is not obscured.

Front protection

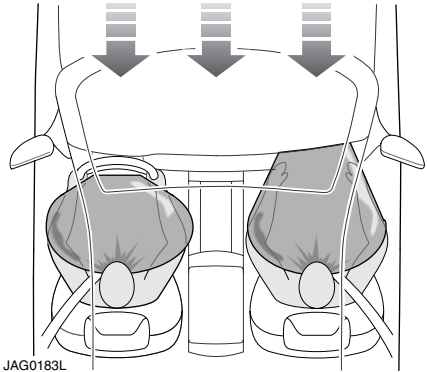

With a front impact of sufficient force, the restraints system will trigger the front air bag(s) and seat belt pretensioners, which immediately tighten the seat belts.

The seat belts then ease, allowing the head and chest to contact the inflated air bag. The air bag absorbs the remaining energy of the impact and then deflates rapidly via vent holes.

Front air bags are designed to inflate only in frontal and near frontal collisions.

Occupant Protection

SIDE AIR BAGS

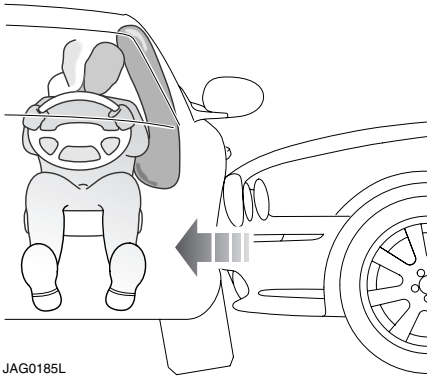

JAG0185L



WARNING:

To ensure that the side air bags are fully effective do not sit too close to, or lean against the door trim. The side air bag could injure you as it deploys from the side of the seat.

The air bags, in combination with the seat belts, can help reduce the risk of severe injuries in the event of a significant side impact collision.

When the seat mounted head and thorax air bag inflates, it breaks through the seat bolster stitching, giving protection to the side of the rib cage and head of the driver or front seat passenger.

The combined head and thorax side air bags are designed to inflate only in a side impact collision, unless the collision causes sufficient lateral deceleration.

AIR BAG WARNING LAMP



The air bag warning indicator in the driver's instrument panel will be lit for approximately six seconds when the ignition is turned on.

If the indicator remains on, it indicates a fault. Report the fault to a Jaguar Dealer immediately. It is safe to drive the vehicle; however, in an accident the air bags may not operate.

Air bag warning lamp information is shown on page 115.

AIR BAG SERVICE INFORMATION

Air bag disposal



WARNING:

Do not attempt to service, repair, replace, modify or tamper with any part of the air bag system or its electrical fuses. Doing so could cause the system to activate, resulting in personal injury.

In the event of the vehicle being dismantled, air bag module removal and disposal must be carried out by a qualified person.

Occupant Protection

WHIPLASH PROTECTION

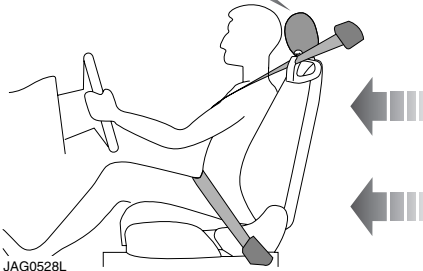
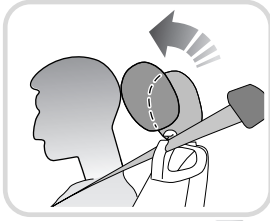

JAG0528L

Both front seats are equipped with Active Head Restraints (AHR) which reduce the risk of neck and spinal injury (**whiplash**) in the event of a rear impact.

When activated, the head restraint moves upwards and forwards, supporting the occupant's head.

After activation, the whiplash protection mechanism automatically resets and does not require to be replaced.

ROLLOVER BARS

(Convertible only)



WARNING:

- Do not place any objects on top of the system trim covers behind the rear passenger head restraints as they could prevent correct deployment of the system.

- Do not try to reset the system if it deploys.
- Do not let anyone sit on the top cover.

The Rollover Protection Device (RPD) consists of two inverted U-shaped bars, that are concealed underneath the rear parcel shelf behind the rear passenger seats, and sensors that monitor the attitude of the vehicle.

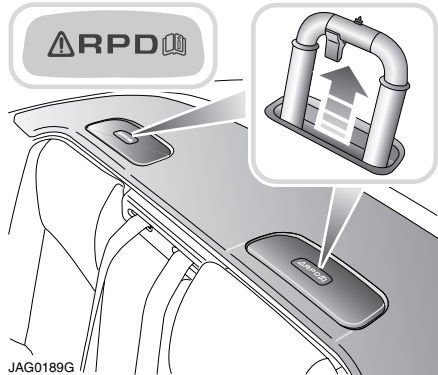

JAG0189G

If the sensors determine that a risk of rollover is imminent, the rollover bars will be deployed.

Note: When the rollover bars are deployed they will deliberately break the rear screen if the convertible top is closed.

If the Rollover Protection Device has been deployed, proceed to your nearest Jaguar Dealer to check for any damage and to reset the system.

Child Safety

CHILD SEATS

General safety information

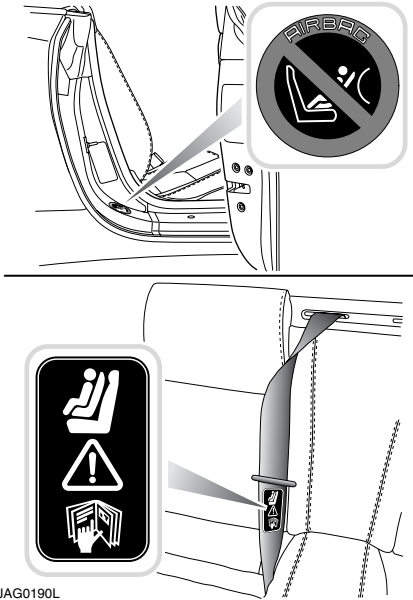

JAG0190L



WARNING:

- **Extreme hazard! Do not use a rearward facing child restraint on a seat protected by an air bag in front of it!**
- **Children must be restrained by a child safety restraint that is suitable for their weight and size.**
- **Children 12 years old and younger can be killed or seriously injured by the air bag. The rear seat is the safest place for properly restrained children.**

- **Do not install a rearward-facing child seat in the front passenger seat position since deployment of the passenger facia air bag could cause death or serious injury to the child.**
If, however, you have no alternative but to place a child in the front passenger seat, use only a forward-facing child seat with the passenger seat set fully rearward and in its lowest position.
- **Always follow the fitting instructions supplied with the appropriate child restraint system. It is important to read and understand all the information contained in this handbook relating to child safety before carrying a child in your vehicle.**
If you are unsure about any aspect of this information, contact your Jaguar Dealer.

In many countries legislation governs how and where children should be carried when travelling in a vehicle.

It is the responsibility of the driver to comply with all regulations in force in the country where the vehicle is being used.

Holding a baby or child in a person's arms is not a substitute for a child restraint system.

In an accident, a baby or child held in this manner can be crushed between the vehicle's interior and a restrained person.

The child can be injured by hitting the interior or by being thrown from the vehicle during a sudden manoeuvre or impact.

Child Safety

The seat belts fitted to your vehicle are designed for adults and larger children. For their safety, it is very important that all infants and children under 12 years of age are restrained in a suitable child safety seat appropriate to their age and size..

Choosing a suitable child seat



WARNING:

Choose a child seat that sits securely on the seat cushion and against the seat back.

Before you buy a child seat, it is important to note that your child's weight, rather than age, determines the type of seat that is required.

Jaguar strongly recommends the use of LATCH seats, see page 106.

Babies and small children who cannot sit up by themselves should be carried in an approved rear facing infant carrier, which should always be installed in a rear seat position.

Jaguar recommends that a rear-facing seat with a harness is used for as long as your infant's development allows.

Note: For approved child restraints, you should contact your Jaguar Dealer.

Do not use a forward-facing seat until your child is above the minimum weight of 9 kg (20 lbs) and able to sit up unaided. Up to the age of two, a child's spine and neck are not sufficiently developed to avoid injury in a frontal impact.

We strongly advise that you do not buy or use a second-hand child seat. The seat may have been used inappropriately, or involved in an accident. In such circumstances, the seat may not protect your child.

Always check that the child seat can be mounted securely in the required position: if in doubt, you should speak to your Jaguar Dealer.

Look for the following when selecting a child restraint system:

- It should have a label certifying that it meets the applicable Regulations.
- Carefully read the instructions supplied with the restraint. Be sure you understand them and can install and use the device properly and safely in the vehicle.
- Ensure that the child restraint system is appropriate for the child's weight and development, refer to page 105..

Infant safety

Babies and small children who cannot sit up by themselves should be carried in an approved rear facing infant carrier, which should always be installed in a rear seating position.

Child Safety

CHILD SEATS

PROPER CHILD SAFETY SEAT USE CHART			
Buckle Everyone. Children Age 12 and Under in Back.			
	INFANTS	TODDLER	YOUNG CHILDREN
WEIGHT	Birth to 1 year at least 20 to 22 lb (9 to 10 kg).	Over 1 year and Over 20 - 40 lb (9 to 18 kg).	Over 40 lb (18 kg) Ages 4 - 8, unless 4ft 9ins (145 cm).
TYPE of SEAT	Infant only or rear facing, convertible.	Convertible / Forward-facing.	Belt positioning booster seat.
SEAT POSITION	Rear-facing only.	Forward-facing.	Forward-facing.
ALWAYS MAKE SURE	Children to 1 year and at least 20 lb (9 kg) in rear-facing seats. Harness straps at or below shoulder level.	Harness straps should be at or above shoulders. Most seats require top slot for forward-facing.	Belt positioning booster seats must be used with both lap and shoulder belt. Make sure the lapbelt fits low and tight across the lap/upper thigh area and the shoulder belt fits snug crossing the chest and shoulder to avoid abdominal injuries.
WARNING	All children age 12 and under should ride in the back seat.	All children age 12 and under should ride in the back seat.	All children age 12 and under should ride in the back seat.

Fitting the child seat

Front and rear passenger seat belts have an automatic locking device for use with child seats.

When engaged, this device allows the belt to be retracted (tightened) but not pulled out. When used to secure a child seat, therefore, the belt will automatically lock at any point to which it has retracted.

1. Pull the seat belt all the way out to engage the locking device.

2. Insert the metal tongue plate into the buckle. A positive click indicates that it is safely locked.
3. To fix the seat firmly, retract the belt back to the reel, a ratchet operation may be felt as the belt retracts. Continue to feed the belt back onto the reel until it fits snugly around the child seat.

Child Safety

4. Push down on the child seat to ensure any slack is taken in by the mechanism.

The above is a guide only. Depending on the features of a particular child seat, e.g. forward or rearward-facing, engage the locking device before or after attaching the belt, as convenient.

Unbuckling the belt and releasing the child seat will allow the belt to resume its normal operation.

General check list

Follow the check list each time your child travels in the vehicle:

- Carefully follow the instructions provided by the manufacturer of the restraint system.
- Make sure your child falls into the correct weight range for the seat.
- Always use the appropriate child restraints and adjust harnesses for every child, every trip.
- Avoid dressing your child in bulky clothing and do not place any objects between the child and the restraint system.
- Regularly check the fit of your child seat and replace seats or harnesses that show signs of wear.
- No child seat is completely child-proof. Encourage your child not to play with the buckle or harness.
- Never leave a child unsupervised in the vehicle.
- Ensure your child does not exit the vehicle from the side where there is traffic.
- Set your child a good example – always wear your seat belt.

- Ensure that you have removed all slack from the adult seat belt.

Child restraint top tether anchorages and brackets (Coupe only)

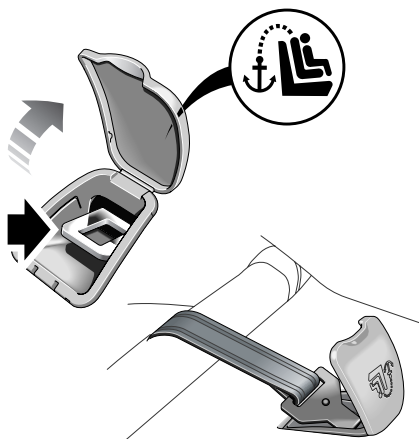

JAG0192G

The top tether brackets are positioned on the rear parcel shelf, under access covers, at the centre-line of each rear seating position.

Lift the top tether cover and connect the top tether to the bracket on the rear shelf. Adjust the length of the top tether strap to hold the top of the child seat against the vehicle seat back.

LATCH ANCHOR POINTS

(Lower Anchorages and Tethers for **CHILD** restraints)

Child Safety



WARNING:

Child restraint anchorages are designed to withstand only those loads imposed by correctly fitted child restraints. Under no circumstances are they to be used for adult seat belts or for attaching other items or equipment to the vehicle.

The rear seats of your vehicle are fitted with LATCH brackets that allow the LATCH child seat to be secured directly and easily to the vehicle body without the use of adult seat belts.

Many injuries to children in accidents are caused by the incorrect fitting and tensioning of the adult seat belts, which are normally used to secure child seats. The LATCH system reduces the likelihood of incorrect fitting and is also quicker and simpler to use.

LATCH child restraint system

Many LATCH child seats have two retractable lower catches that lock onto the anchorage loops, see page 108, and a strap that clips onto the top tether bracket, see page 106. The child seats may have quick release mechanisms to allow them to be removed easily.

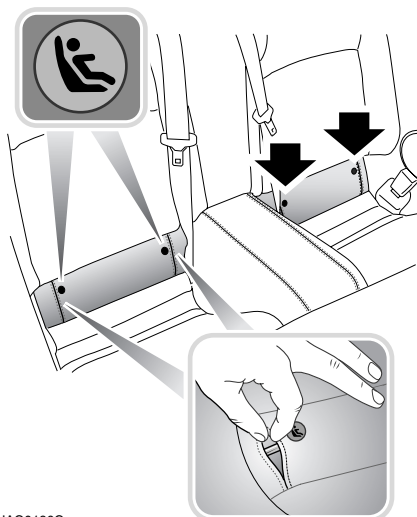

JAG0196G

The anchorage loops are accessible through two trimmed apertures at the back of the rear seat cushion. Their location is highlighted by the small tag labels with a child seat graphic. The anchorage loops are located approximately 60 mm (2.5 inches) below each label. Pull back the side of the trim as indicated, see illustration, to reveal the aperture and the anchorage loops.

Child Safety

Installing the LATCHISOfix seat

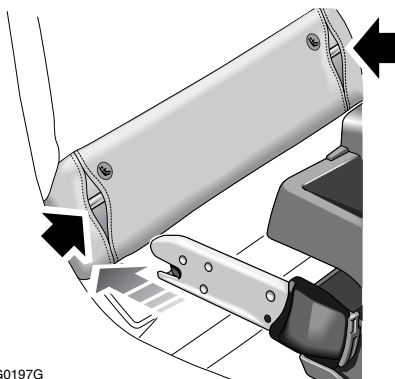

JAG0197G

To ensure that the LATCHISOfix child seat is installed safely, read all the information provided in this Section.



WARNING:

Always follow the manufacturer's instructions supplied with the LATCHISOfix child seat. The following is to be considered only as a guide.

Fit the seat as follows:

1. Push the adult seat belt buckles into their stowage recesses, to ensure they do not interfere with the fitment of the child seat.
2. Make sure there is nothing obstructing the seat mounting mechanism at the anchorage points.
3. Release the lever on the rear of the seat and fully extend the two attachment legs on the child seat. Ensure the hook at the end of each leg is open.

4. Position the attachment legs just in front of the trimmed apertures for the LATCHISOfix anchorage loops (see illustration). Push the anchorage leg through the trimmed aperture to engage with the vehicle's anchorage loop. There should be an audible click.
5. Repeat Step 4 for the seat's second anchorage leg.
6. Using firm and even pressure on both sides, push the child seat rearwards until it is secured firmly against the seat back. Make sure you do not trap the top tether strap behind the child seat.
7. If your vehicle is fitted with top tether anchorages brackets, make sure that the top tether strap is secured to the anchorage bracket, see page 106.
8. As a final check, firmly pull both sides of the seat to confirm that it is correctly locked in position.

Caution: Always follow the manufacturer's instructions supplied with the LATCHISOFIX child seat.

Removing the LATCHISOfix seat

To remove the LATCHISOfix child seat, press the locking button on each side of the seat to release anchorage legs. If your vehicle is fitted with top tether anchorages, undo the top tether strap and lift the child seat from the vehicle.

BOOSTER CUSHIONS

If a booster cushion is used, position the lap section of the adult seat belt over the child's pelvis. The diagonal seat belt should rest on the child's shoulder, not the neck.

Facia and Controls

CONTROL LOCATIONS

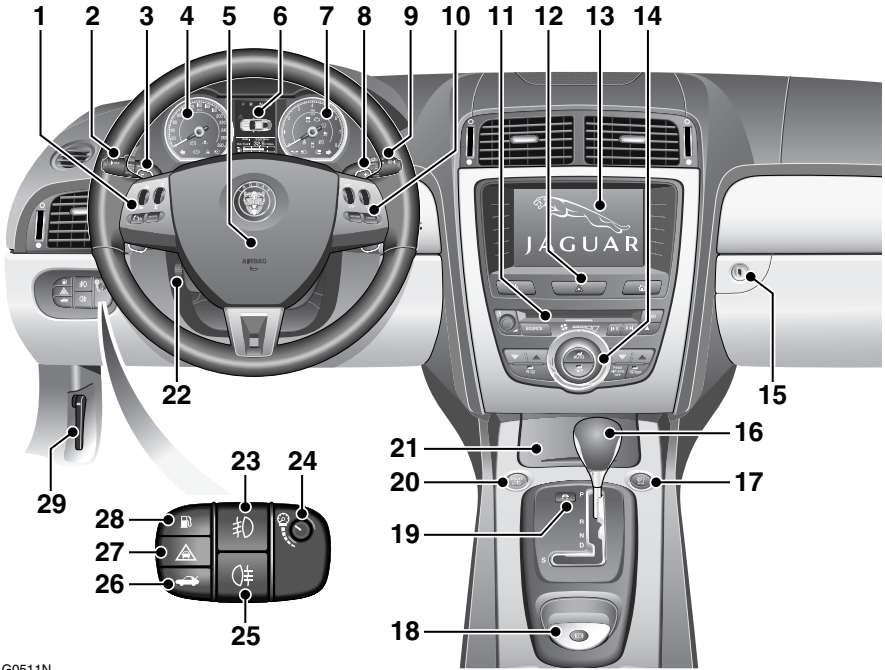

JAG0511N

Facia and Controls

1. Steering wheel audio switches (64).
2. External light switches (71).
3. Jaguar sequential gear change down paddle (159).
4. Speedometer (111).
5. Driver's horn and air bag (63).
6. Message centre (111).
7. Tachometer (111).
8. Jaguar sequential gear change up paddle (159).
9. Wiper and washer switch (65).
10. Cruise control or adaptive cruise control switches (169).
11. Audio panel (184).
12. Hazard warning switch (76).
13. Touch-screen display (121).
14. Climate control panel (132).
15. Glove box compartment release button (142).
16. Gear selector (157).
17. Automatic speed limiter switch (180).
18. Parkbrake switch (164).
19. Dynamic stability control mode switch (166).
20. Engine START/STOP switch (50).
21. Ashtray and cigar lighter (140).
22. Steering column adjustment switch (62).
23. Front fog lamp switch (75).
24. Dimmer switch (140).
25. Rear fog lamp switch (75).
26. Luggage compartment release switch (43).
27. Forward alert switch (177).
28. Fuel filler flap release switch (52).
29. Hood release lever (234).

Page numbers (shown in brackets) refer to pages in this handbook that have further relevant information.

Instruments

INSTRUMENT PANEL OVERVIEW

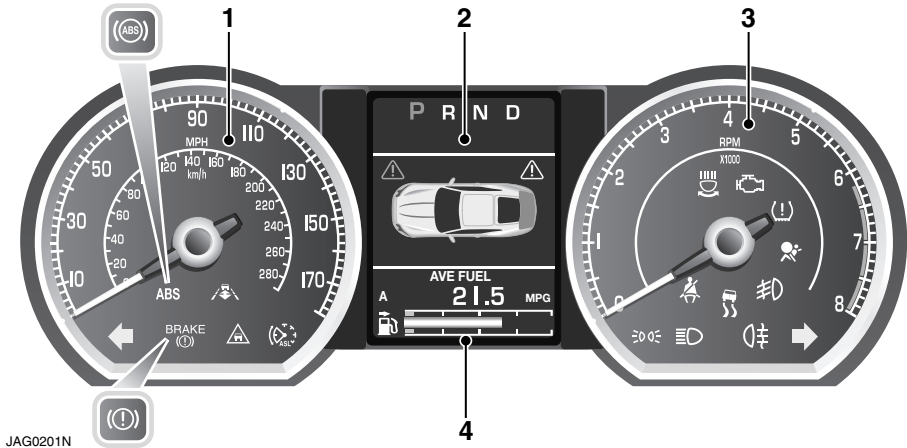

JAG0201N

None of the instruments will show correct indications until the ignition system is in the ON condition, see page 50.

1. Speedometer

Speed indication is in either:

USA - miles per hour, the outer figures, and kilometres per hour on the inner ring.

Canada and Mexico - kilometres per hour, the outer figures, and miles per hour on the inner ring.

2. Message centre

For more detailed information on the message centre, see page 118.

Message centre illumination

The message centre is lit at all times when the ignition is ON, see page 50.

3. Tachometer

Indicates engine speed in revolutions per minute (x 1 000) and is calibrated in increments of 250 rev/min.

Caution: Do not allow the needle to enter the red sector.

4. Fuel gauge

The small arrow on the top of the fuel pump symbol indicates which side of the vehicle the fuel filler cap is located.

The message centre will display the message **FUEL LEVEL LOW** when the fuel level is approximately 1/16 tank capacity, approximately a distance range of 48 to 64 km (30 to 40 miles).

Instruments

WARNING LAMPS AND INDICATORS

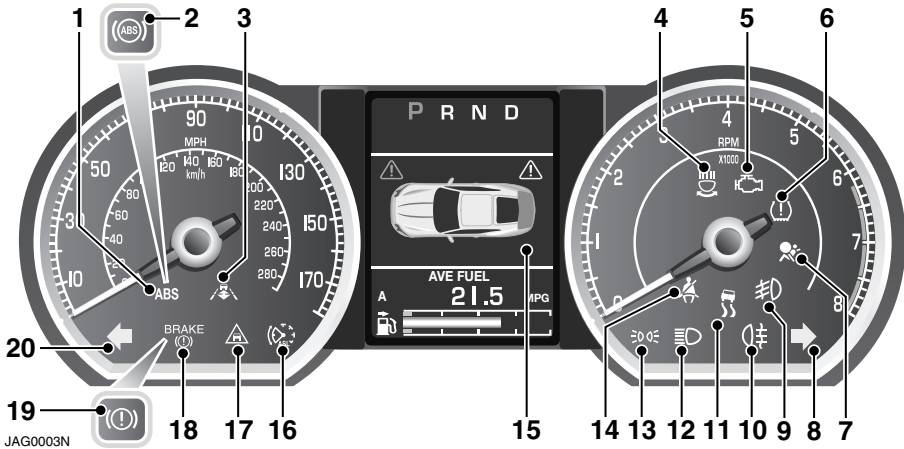

1. Anti-lock braking system (ABS) - USA only.
 2. Anti-lock braking system (ABS) - Canada only.
 3. Adaptive cruise control (ACC).
 4. Active front lighting system (AFL).
 5. Engine malfunction.
 6. Tire pressure monitoring system (TPMS).
 7. Air bag.
 8. Right-hand direction indicator.
 9. Front fog lights.
 10. Rear fog light.
 11. Dynamic stability control (DSC).
 12. High beam.
 13. Side lamps.
 14. Seat belt.
 15. Driver information center.
 16. Automatic speed limiter (ASL).
 17. Forward alert.
 18. Parkbrake on/brake fluid low - USA only.
 19. Parkbrake on/brake fluid low - Canada only.
 20. Left-hand direction indicator.
- RED** warning lamps are for primary warnings. A primary warning must be investigated immediately by the driver or a Jaguar Dealer.
- AMBER** warning lamps are for secondary warnings. Some indicate that a vehicle system is in operation, others indicate that the driver must take action and then report the fault to a Jaguar Dealer at the earliest opportunity.
- Other lamps within the instrument cluster indicate system status, such as blue for main beam and green for direction indicators, when in operation.

Instruments

Lamp check

A lamp check is initiated when the ignition system is in the ON condition and lasts for three seconds (excepting the air bag warning lamp which will remain ON for six seconds). If any warning lamp remains ON after this period, investigate the cause before driving.

Some warning lamps have associated messages displayed on the message centre.

Note: *Not all lamps are included in the lamp check, for example main beam headlights or direction indicators.*

Brake (Red)



WARNING:

If the message LOW BRAKE FLUID is displayed, do not drive the vehicle until the brake fault is rectified. Consult a Jaguar Dealer immediately.

BRAKE

Illuminates when:

- the ignition system is ON and the parkbrake is ON
- and, or the brake fluid is low
- and, or there is a fault with the electronic brake system.

If the light is ON and there are no associated messages it means that the parkbrake is applied.

If the light flashes, there is a fault with the parkbrake system and the parkbrake cannot be applied.

If the indicator lamp is ON and the message **PARK BRAKE APPLIED** is displayed, it means that the parkbrake is applied but the vehicle is moving. Release the parkbrake or stop the vehicle when it is safe to do so.

If the indicator lamp is ON and the message **BRAKE FLUID LOW** with a RED priority light is displayed on the message centre, low brake fluid is indicated. In this case, loss of braking in one or both brake circuits may be imminent. Stop the vehicle gently and seek qualified assistance.

Seat belt (Red)



The warning light stays on for 60 seconds when the ignition is ON and:

- The driver's seat belt is not fastened.
- Or after a passenger is sitting in the front seat and their seat belt is not fastened.

The indicator lamp should go out when the driver's seat belt (and the front passenger's if the seat is occupied) is fastened.

Beltminder



The beltminder feature, which uses the same indicator as the seat belt warning, provides reminders to the driver that the driver's and/or front passenger's seat belt is unbuckled.

If the vehicle is moving at or above 16 km/h (10 mph) and the seat belt of an occupied seat is not fastened, the indicator lamp will flash.

Instruments

The flashing will last for ten seconds and then repeat every 30 seconds for approximately five minutes or until the belt(s) is fastened or the vehicle stops.

If the warning indicator stays ON with the seat belt(s) fastened, report the fault to a Jaguar Dealer. It is safe to drive the vehicle with the light ON, provided that the seat belt(s) is properly fastened. Ensure that all occupants seat belts are fastened before driving.

Note: *If a heavy object is placed on the front passenger seat it may activate the Beltminder feature. It is recommended that the object be placed in the luggage compartment.*

Anti-lock braking system (ABS) (Amber)



WARNING:

If the ABS and brake warning indicators are ON at the same time, do not drive the vehicle until the fault is rectified. Consult a Jaguar Dealer immediately.

ABS

Illuminates if a fault has been detected in the anti-lock brake system (ABS) or the electric parkbrake system. A warning message will appear to indicate either ABS or parkbrake fault.

The brake system will continue to function normally, but without ABS braking.

If the indicator lamp comes on or stays on after the bulb check cycle, the vehicle should be driven to a Jaguar Dealer at the earliest opportunity.

Active front lighting (Amber)



Illuminates when there is a system fault. Report the fault to a Jaguar Dealer as soon as possible.

Engine malfunction (Amber)



Illuminates when the ignition system is ON and remains on until the engine is started.

If the indicator comes on when the engine is running then there is an engine malfunction.

Specialised diagnostic equipment is required to repair such faults. Report the fault to a Jaguar Dealer.

The vehicle may go to limp-home mode, with the possibility of reduced engine performance. Drive with caution.

Dynamic stability control (DSC) (Amber)



The indicator will flash twice every second when DSC is operating.

The message **DSC NOT AVAILABLE** will be displayed and the indicator lamp will be ON continuously if a fault is detected.

When Trac DSC is selected the message **TRAC DSC** is displayed for four seconds and the warning indicator remains illuminated.

DSC OFF (normally aspirated engines only):

If the system is turned OFF, a message **DSC OFF** will be displayed at all times and the warning indicator will remain ON.

When the system is turned back ON the warning indicator goes out and a message **DSC ON** will be displayed for four seconds.

Instruments

Rear fog lamp (Amber)



Illuminates when the rear fog lamp is switched ON.

Automatic speed limiter (Green)



Illuminates when automatic speed limiter is active.

Adaptive cruise control (Amber)



Illuminates when adaptive cruise control is active to indicate that the vehicle is in follow mode.

Front fog lamp (Green)



Illuminates when the front fog lamps are switched ON.

Forward alert (Amber)



Illuminates when Forward Alert is active.

Side lamps (Green)



Illuminates when the side (parking) lamps are switched ON.

Air Bag (Amber)



Flashes if the air bag system or the Roll Over Protection System (Convertible only) develops a fault. Then illuminates permanently until the fault has been diagnosed and cleared.

Report the fault to a Jaguar Dealer immediately.

Direction indicators (Green)



The appropriate indicator will flash when the column stalk is moved up or down to signal a turn. If a direction indicator fails, the audible ticking and lamp will sound and flash at twice normal rate when that indicator is selected.

Tire pressure monitoring system (Yellow)



Illuminates when one or more tires are significantly under inflated. The vehicle should be stopped as soon as possible and the tires checked and inflated to the recommended pressure.

Hazard warning lights

When the hazard warning switch is used, both direction indicator tell-tales flash simultaneously.

High beam (Blue)



Illuminates when the high beam is switched ON or flashed ON.

Instruments

AUDIBLE WARNINGS AND INDICATORS

Various sounds are produced for warning and notification purposes as follows:

Hazard or Condition	Chime or tone/remedy
External lights remain ON when the driver's door is opened.	A chime will sound until the lights are switched OFF or driver's door is closed. The chime will not sound if the lighting control is in AUTO position.
Hazard warning indicators ON.	A ticking will sound until the hazard indicators are switched OFF.
Direction indicators ON.	A ticking will sound until the indicators are switched OFF.
Memory 1, 2 or 3 configuration saved.	A short tone as the memory selection is saved.
Air bag system failure.	A tone sequence is repeated five times. Report the fault to a Jaguar Dealer as soon as possible.
Seat belt reminder.	A chime will sound until an unfastened seat belt is fastened. The warning will cease if all the front seats are occupied and the seat belts are buckled, the vehicle is brought to a halt, the ignition is turned OFF or more than approximately five minutes has elapsed with the vehicle in motion, the ignition on and an occupied seat's belt unbuckled.
Electric parkbrake.	If the parkbrake is applied whilst the vehicle is moving a continuous chime is initiated; release the parkbrake. If there is a fault with the system which would prevent the application of the parkbrake, a brief sequence of chimes is initiated.
Adaptive Cruise Control (ACC) Driver intervene and Forward Alert.	Multiple chime. Apply the brakes.
ACC low speed automatic switch off.	A chime will sound to indicate that the ACC system is no longer operating.
Speed is over 15 km/h (9 mph) above the set limit speed.	A short warning chime.Reduce speed.
Gear selector is not in Park with ignition OFF.	A chime will sound. Select Park.
Convertible roof starting to open or close.	High-pitched single chime.

Instruments

The Jaguar Smart Key cannot be detected.	A chime will sound. The remote handset should be inserted into the starter control unit, see page 37.
The Jaguar Smart Key is to be removed from the starter control unit.	A chime will sound for 60 seconds if the Jaguar Smart Key is in the starter control unit and the driver's door is opened. The remote handset should be removed from the starter control unit.
DSC OFF (Normally aspirated engines only)	A chime will sound.

Information Displays

GENERAL INFORMATION

The driver information centre display panel is situated within the instrument cluster between the tachometer and speedometer gauges.

The information centre is active as soon as a door is opened for access.

The primary function of the message centre is to inform the driver of the following:

- warning messages
- temporary alert messages
- information messages.

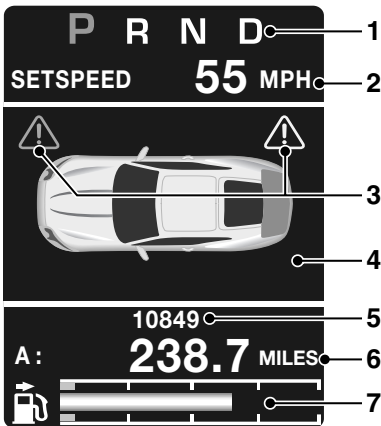

JAG0204N

The message centre screen is divided into various zones displaying the following:

1. Gear selection, automatic or manual.
2. Speed control related information.
3. Priority warning indicators.

4. Warning messages, red or amber, if system faults are detected. Status messages are displayed to indicate changes in state of certain vehicle functions, e.g. navigation, telephone. The clock can be shown when no other information is required to be displayed, see page 142.
5. Trip computer information, including total distance covered by the vehicle, see page 119.
6. Set trip computer information display relating to **A**, **B** or **Auto** trip computer, see page 119.
7. The fuel level gauge, which changes colour from blue to red when the fuel level drops to the reserve fuel level indicator. The small arrow on the top of the fuel pump symbol denotes which side of the vehicle the fuel filler cap is located.

INFORMATION MESSAGES



WARNING:

If a red warning indicator is displayed, stop the vehicle as soon as possible when it is safe to do so.

Most messages, when displayed have an associated warning light, red or amber, which will come on to indicate the message priority. Also from time to time information messages will be displayed.

If more than one message is active, each is displayed in turn for two seconds in order of priority.

Messages take priority over the trip computer data and will be displayed when the ignition is in the **convenience mode**, see page 42.

Information Displays

Note: The message centre information messages and their meanings are detailed within the appropriate subject sections.

TRIP COMPUTER

The computer memory stores data for a journey or series of journeys until it is reset to zero.

The displayed information is for guidance only, as it can be affected by traffic, road and weather conditions.

Three independent memories are available, A, B and Auto. A and B memories can be set independently, while the Auto trip will reset after every ignition cycle as the vehicle moves.

Full trip computer information for the trip memories can be displayed on the vehicle touch-screen located in the centre console, while current selected trip computer information is displayed on the instrument cluster message centre.

To access the trip computer touch-screen settings:

- From the main **Home** touch-screen menu, select **Vehicle**.
- Select **Trip computer**.
- Select requirements from the menu.

A system flow chart is given on page 128.

Trip computer message centre display

Vehicle total distance travelled **1**, trip distance **2** are displayed as well as, average fuel economy and average speed if selected via the touch-screen. Also A, B or Auto will be displayed, depending on the current memory selected.

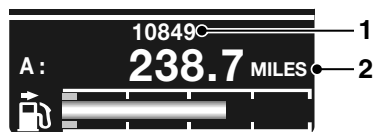

JAG0532N

Odometer

The odometer shows the total vehicle distance travelled since the vehicle was new.

The odometer and trip distance reading is displayed in either miles or kilometres, depending on the units selected via the touch-screen, see page 128.

Changing the display

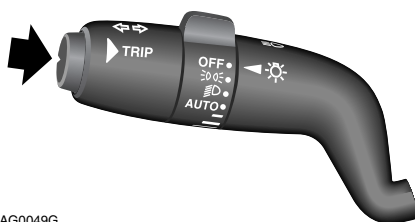

JAG0049G

Press the **TRIP** button on the end of the left column stalk switch repeatedly to display the message centre data in the following order:

- trip distance
- average speed
- average fuel consumption
- range.

Trip distance (A, B and Auto)

Distance travelled since the last memory reset. The maximum trip reading is 16,090 kilometres (9,999.9 miles). The computer will automatically reset to zero if this distance is exceeded.

Information Displays

Average fuel consumption (A, B and Auto)

The average fuel consumption, litres per 100 kilometres, miles per litre or miles per gallon, based on the accumulated distance travelled and the accumulated fuel used.

Range

This shows the predicted distance, miles or kilometres, that the vehicle should travel on the remaining fuel, assuming average fuel economy and fuel consumption stay constant.

Average speed (A, B and Auto)

The average speed since the last press of the reset button.

ML/km (also Miles/litre)

The distance display of imperial or metric units is selected via the touch-screen, see page 128.

Display language

The the display language is selected via the touch-screen, see page 128.

Reset

The resetting of the trip memories is carried out via the touch-screen, see page 128.

Information Displays

TOUCH-SCREEN

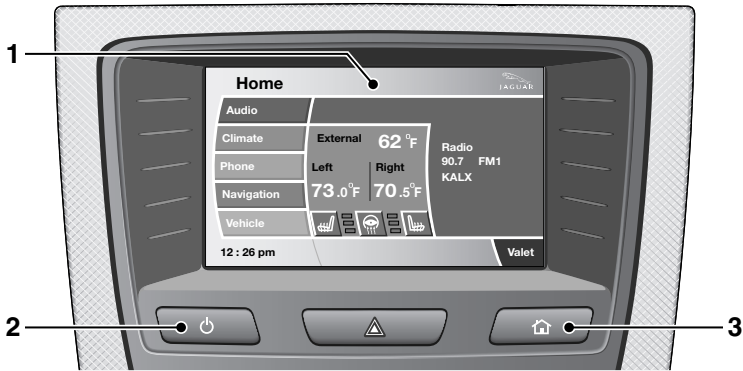

JAG0007NAS

Note: Information operation is given in the *Information Displays*, page 118, which incorporates the systems controlled via the touch-screen.

Note: When the engine is stopped, for the touch-screen to remain active, press the engine START/STOP button again without pressing the brake pedal (ignition system ON).

- 1. Touch-screen:** When initially activated, the touch-screen will display the main **Home** screen. From this main **Home** screen all touch-screen facilities and operations are initiated by pressing the relevant system touch-screen buttons and icons.
- 2. Touch-screen ON/OFF:** Press once to turn the screen ON, press again to revert to screen-saver mode. A further press will turn the touch-screen OFF. When the engine Start/Stop button is pressed, the touch-screen is activated by the ON/OFF switch on the touch-screen console.

- 3. HOME screen button:** Press to return to the main **HOME** screen page from all facilities.

System facilities

There are five major systems controlled via the touch-screen with their individual levels of operation and settings. They are as follows:

- **Audio:** Radio display AM/FM, CD.
- **Climate:** Air conditioning, Distribution, Seats, Heated steering wheel, Automatic air recirculation.
- **Phone:** Digit dialler, Phone book, Last ten calls (made, received, missed).
- **Navigation:** Destination, Stored locations, Navigation setup, Route options. Refer to navigation handbook.
- **Vehicle:** Security, Parking, Valet mode, Trip computer, Clock, Brightness, Contrast, System settings, Vehicle settings, Display settings.

Information Displays

Touch-screen use



WARNING:

In the interest of road safety, only operate, adjust or view the system when it is safe to do so.

Caution: Always run the engine during prolonged use of the touch-screen.

Failure to do so may discharge the vehicle battery, preventing the engine from starting.

When the engine START/STOP button is pressed, the touch-screen can be activated by the ON/OFF switch on the touch-screen console.

The buttons surrounding the touch-screen display are referred to as **hard buttons** and should be pressed firmly. The touch-screen buttons are **soft buttons** and only require a short, light pressure to function. Do not use excessive pressure.

When operating touch-screen buttons, always extend the tip of one finger, and withhold the thumb and remaining fingers from the screen. Touching the screen with more than one finger at a time may cause false inputs.

Throughout the handbook, the expression **Select an item** (or similar wording) means **touch the on-screen button** to select or alter the required item.

The handbook shows the on-screen menus, explains how to operate the controls and illustrates how to select or alter settings and requirements. After becoming familiar with the controls, follow the on-screen menus and prompts, to operate the system as required.

Where it is thought that guidance through the touch-screen menus is necessary, additional information has been given within that section or subject.

Touch-screen display icons

Touch-screen display icons are as follows, (they may not all be displayed at the same time):



Return to the previous screen displayed.



Warning triangle button indicating a warning pop-up message. Touch the pop-up to cancel. The warning message will be displayed on the message centre screen.



Telephone: send button.



Telephone: end call.



Page up or increase setting to required value.



Page down or decrease setting to required value.



Direct access to the valet mode setting screen.



Telephone signal strength indicator.



Telephone battery charge indicator.



No phone connected.

Information Displays

Touch-screen care

Caution: Care must be taken to avoid spilling or splashing drinks onto the touch-screen.

Do not use any abrasive cleaners to clean your touch-screen. For approved screen cleaners, contact your Jaguar Dealer.

The touch-screen inner bezel must be kept clean to maintain optimum performance. Finger marks and attracted dust should be regularly removed using a soft cloth and Jaguar approved cleaning agent.

Where possible, avoid exposing the touch-screen to direct sunlight for long periods.

PERSONALISED SETTINGS

General Information

The touch-screen provides touch-control of the vehicle Audio, Climate, Phone, Navigation and Vehicle systems, as fitted.

Note: When the vehicle engine is stopped the touch-screen reverts to the stand-by mode. To activate the touch-screen press the engine Start/Stop button again.

Home screen display

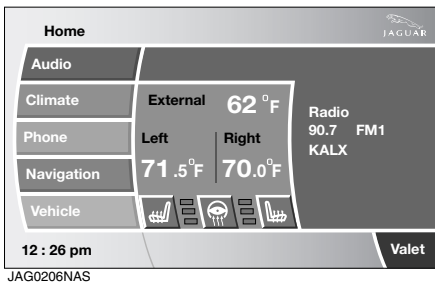

When initially activated, the touch-screen will display the main **Home** screen. The **Home** screen may also be displayed at any time by pressing the **Home** button on the screen surround.

Screen settings: The touch-screen brightness and contrast can be set to individual requirements, including dimming for night driving. This is accessed via the **Vehicle** settings system. Select **Cont./Bright.**

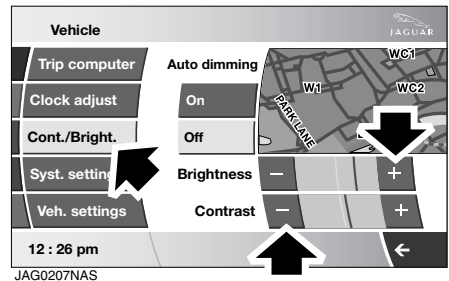

Select **Day** or **Auto dimming**

Day: Brightness and contrast can be adjusted to personal requirements by selecting the (+) or (-) buttons.

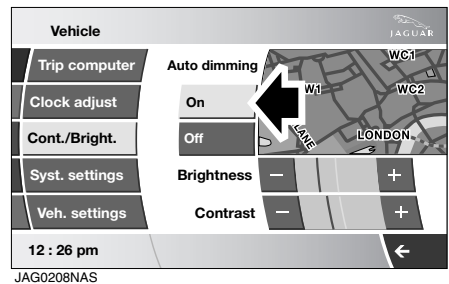

Information Displays

Auto: Select either **On** or **Off**. Brightness and contrast are automatically adjusted by the ambient light level. As the light level decreases the touch-screen brightness will decrease until the full night screen level of brightness is initiated.

Further adjustment of the touch-screen brightness can be achieved by using the (+) or (-) buttons in the **Cont./Bright** screen or by adjustment of the instrument panel dimmer switch, see page 140.

Pop-up messages

The operation of certain functions will cause a small message, pop-up, to appear overlaying the touch-screen display.

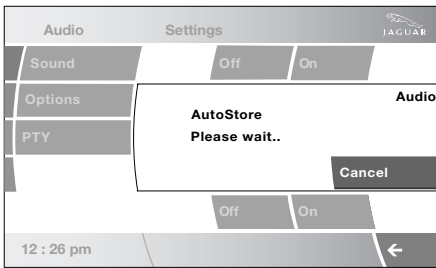

JAG0209NAS

The **pop-up** is mainly for information and will disappear automatically after a few seconds, or can be dismissed by touching the **pop-up** screen area.

If any action or adjustment is required the message will clearly indicate what is required and which button to touch.

Touch-screen systems

There are five major systems controlled via the touch-screen with their individual levels of operation and settings. They are as follows:

- **Audio**

- **Climate**
- **Phone**
- **Navigation**
- **Vehicle.**

Audio system

The vehicle audio system interacts with Navigation, In-car Telephone and Climate Control systems.

The audio system, see page 184, can be controlled from the switches on the touch-screen console, the touch-screen buttons and from the multi-function controls on the left-hand side of the steering wheel.

The system structure is shown as a flow chart on page 127.

Automatic climate control

The automatic climate control system, see page 132, can be controlled from the touch-screen buttons.

Phone

The communications system is composed of the following facilities:

- phone
- digit dialler
- phone book
- last ten calls made, received, missed.

The telephone system, see page 210, is controlled from the touch-screen and the multi-function controls on the left-hand side of the steering wheel.

Navigation system

See the Navigation Handbook for detailed information on the operation of the navigation system.

Information Displays

Vehicle system

The following system functions are set using the touch-screen:

- trip computer
- clock adjust
- contrast and brightness
- system settings
- vehicle settings.

The system structure is shown as a flow chart on page 127.

Languages and distance units

The screen text and distance units are available in various languages and either Imperial or Metric units respectively.

The required languages and units are accessed by selecting **Vehicle** on the main system **Home** screen, then selecting:

- **Trip computer**
- **Units change**
- **Preferences** and then selecting from the menu.

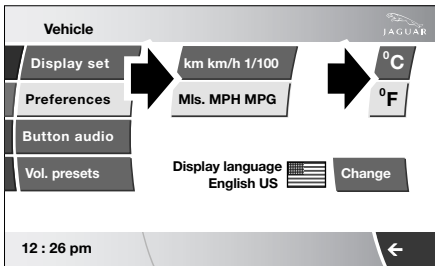

JAG0210NAS

To change the units: The unit choices are selected by pressing the buttons either - **km, km/h 1/100** or **Mls. MPH MPG**.

Temperature display is selected by pressing either °° **°C** or °°**F**.

Note: Celsius or Fahrenheit may be selected independently of metric or Imperial units.

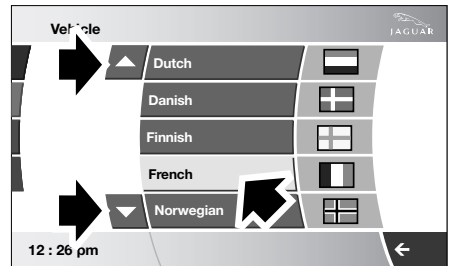
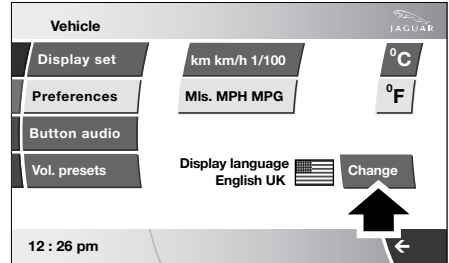

JAG0211NAS

To change the language: The language choices are displayed as a list. Scroll up or down through the list using the up or down arrows.

Note: The navigation system is not affected by the language change. To change the navigation system language display, refer to the Navigation Handbook.

Information Displays

Timeout to home screen

The Timeout to home screen (return to display the Home screen) can be adjusted.

From the main Home screen select the **Vehicle** button.

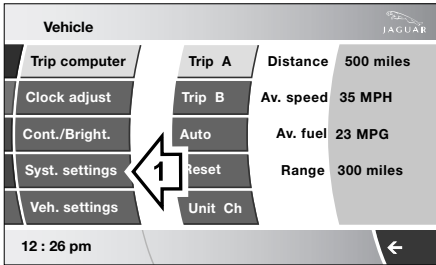

JAG0231NAS

1 Select the **Syst. settings** button.

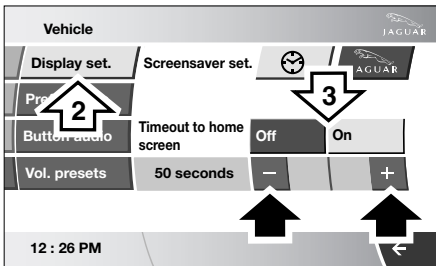

JAG0544NAS

Select **Display set 2** followed by **Timeout to home screen** either **On** or **Off 3**. Using the slider bar the time out can be adjusted from 10 seconds to five minutes.

Note: An initial default setting of one minute is set if no time adjustment is made.

Information Displays

Menu structure

The following menu outlines represent the touch-screen **Audio**, **Vehicle** and **Telephone** system structure.

Audio

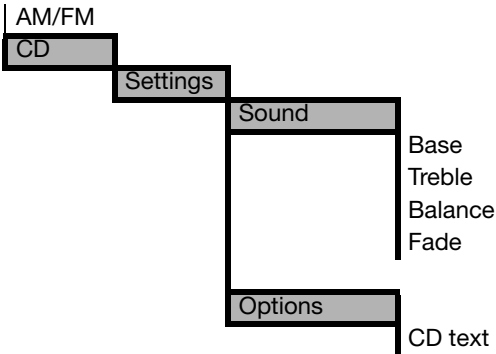
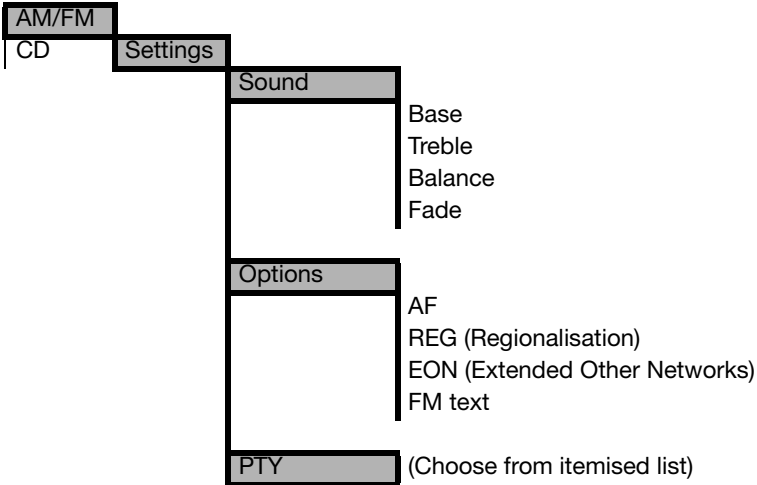

Information Displays

Vehicle

Trip computer																	
Clock adjust Cont./Bright Syst. settings Veh. settings	<table border="1"> <tr> <td>Trip A</td> <td>Distance Av speed Av fuel Range Reset</td> </tr> <tr> <td>Trip B</td> <td>Distance Av speed Av fuel Range Reset</td> </tr> <tr> <td>Auto</td> <td>Distance Av speed Av fuel Range Add/Delete trip</td> </tr> <tr> <td>Units</td> <td> <table border="1"> <tr> <td>Display set</td> <td>Screen saver Time out to home screen</td> </tr> <tr> <td>Preferences</td> <td>Units (Change from Metric to Imperial) Display language</td> </tr> <tr> <td>Button audio</td> <td>Audible</td> </tr> <tr> <td>Vol. presets</td> <td>Facilities volume set AVC (Automatic volume control)</td> </tr> </table> </td> </tr> </table>	Trip A	Distance Av speed Av fuel Range Reset	Trip B	Distance Av speed Av fuel Range Reset	Auto	Distance Av speed Av fuel Range Add/Delete trip	Units	<table border="1"> <tr> <td>Display set</td> <td>Screen saver Time out to home screen</td> </tr> <tr> <td>Preferences</td> <td>Units (Change from Metric to Imperial) Display language</td> </tr> <tr> <td>Button audio</td> <td>Audible</td> </tr> <tr> <td>Vol. presets</td> <td>Facilities volume set AVC (Automatic volume control)</td> </tr> </table>	Display set	Screen saver Time out to home screen	Preferences	Units (Change from Metric to Imperial) Display language	Button audio	Audible	Vol. presets	Facilities volume set AVC (Automatic volume control)
Trip A	Distance Av speed Av fuel Range Reset																
Trip B	Distance Av speed Av fuel Range Reset																
Auto	Distance Av speed Av fuel Range Add/Delete trip																
Units	<table border="1"> <tr> <td>Display set</td> <td>Screen saver Time out to home screen</td> </tr> <tr> <td>Preferences</td> <td>Units (Change from Metric to Imperial) Display language</td> </tr> <tr> <td>Button audio</td> <td>Audible</td> </tr> <tr> <td>Vol. presets</td> <td>Facilities volume set AVC (Automatic volume control)</td> </tr> </table>	Display set	Screen saver Time out to home screen	Preferences	Units (Change from Metric to Imperial) Display language	Button audio	Audible	Vol. presets	Facilities volume set AVC (Automatic volume control)								
Display set	Screen saver Time out to home screen																
Preferences	Units (Change from Metric to Imperial) Display language																
Button audio	Audible																
Vol. presets	Facilities volume set AVC (Automatic volume control)																

Information Displays

Trip computer

Clock adjust

Cont./Bright

Syst. settings

Veh. settings

Adjust time

Clock display

12/24 hour

Set

Trip computer

Clock adjust

Cont./Bright

Syst. settings

Veh. settings

Day

Auto

Brightness

Contrast

Trip computer

Clock adjust

Cont./Bright

Syst. settings

Veh. settings

Display set

Screen saver

Time out to home screen

Preferences

Units (Change from Metric to Imperial)

Display language

Button audio

Audible (On/Off)

Vol. presets

Facilities volume set

AVC (Automatic volume control)

Information Displays

Trip computer
Clock adjust
Cont./Bright
Syst. settings

Veh. settings

Security

2 stage unlock
Drive away locking

Parking

Reverse mirror dip

Valet mode

(Enter a PIN security number)

Phone

Phone

DigiDial

Make a call

Names

Name search

Last 10

Made

Received

Missed

Settings

Register

Undock

Change phone

Search new

Information Displays

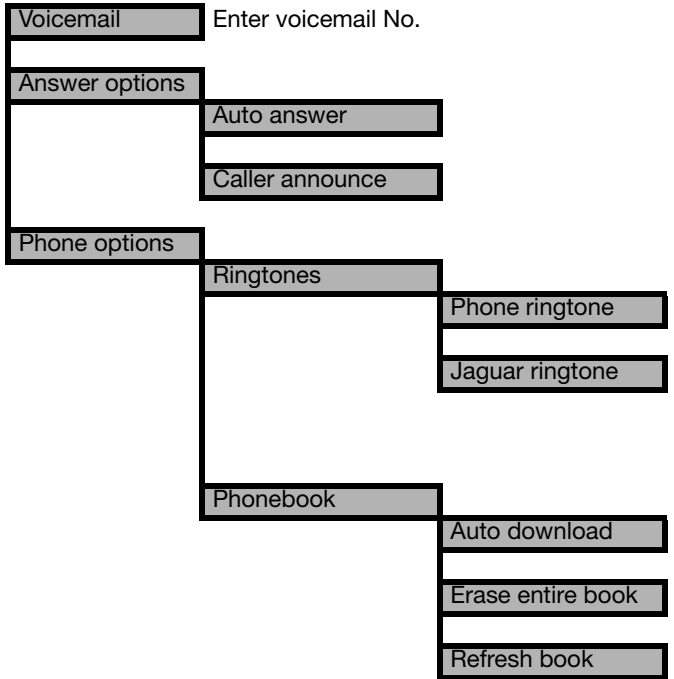

Climate Control

PRINCIPLE OF OPERATION



WARNING:

Do not disconnect any pipes in the air conditioning refrigeration system. A refrigerant is used which can cause blindness if allowed to contact the eyes. If refrigerant should contact the eyes or skin, wash the eyes or affected area with cold water for several minutes. Do not rub. As soon as possible thereafter, obtain treatment from a doctor or eye specialist.

The climate control panel is located in the centre console. There are two control facilities:

- A dedicated control panel located below the audio and CD panel for operation of basic features.
- A touch control and display unit for additional functions and personal settings.

The climate control system features automatic temperature and air distribution control, which is programmed to maintain optimum levels of comfort within the vehicle in all but the most severe conditions.

While the controls can be adjusted manually to satisfy individual requirements, allowing the system to function automatically (in **AUTO** mode) is by the simplest method of operation and is preferable in most operating conditions.



In Auto mode air recirculation sensor detects pollutants and selects air recirculation when the level of pollution outside the vehicle reaches a certain level. The sensor response level can be adjusted on the touch-screen.

Once the level of pollutants decreases, air recirculation will switch off.

To set the automatic air recirculation sensitivity level of the pollution sensor:

- From the Climate Control **home** screen select **Settings**.
- Adjust the automatic air recirculation sensitivity setting as required by selecting the (+) or (-) buttons.

Use of air conditioning

Note: *To prevent humidity build up inside the vehicle and possible screen misting, avoid driving with the air conditioning system off or in manual air recirculation for prolonged periods.*

Air conditioning is an integral part of the climate control system, providing cooled and dehumidified air for occupant comfort. The dry airflow is also effective in preventing misting of the windows.

While the air conditioner can be manually switched off, it is recommended that it is used in all climatic conditions throughout the year, preferably in **AUTO** mode.

Climate Control

Close all windows and the convertible top when the air conditioning is on to ensure satisfactory operation.

- If the air conditioning system is not used frequently, it should be run briefly at least once each week, with a cold setting. This will prevent the seals from drying out with subsequent refrigerant leaks.
- Surplus water produced by the dehumidifying process is expelled from the system via drain tubes beneath the vehicle. This may result in a small pool of water forming on the road when the vehicle is stationary and is not a cause for concern.

Climate Control

AIR VENTS

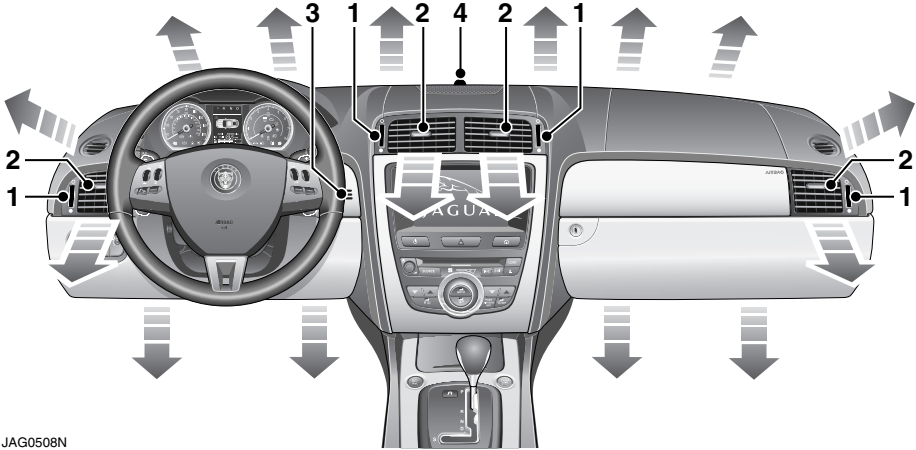

JAG0508N

The air vents provide fresh or heated air to the interior of the vehicle. Ensure that the air intake grille at the base of the windshield is kept clear of any obstruction.

Air flow and direction can be adjusted with the thumbwheel controls **1** and direction vanes **2**.

AUTOMATIC CLIMATE CONTROL

Automatic climate control provides efficient regulation of the vehicle environment without constant adjustments from the occupant.

Sensors inside the vehicle monitor temperature, humidity **3** and direct sunlight **4**. Do not obstruct these openings. In response to sensor indications, the electronic control system automatically adjusts the heat input, blower speed, air intake and airflow distribution to maintain the selected temperature(s) and reduce misting.

Automatic operation provides optimum comfort under most driving conditions.

It is recommended that automatic control, AUTO, is selected as the normal operating mode.

Automatic control, **AUTO**, can be overridden at any time.

Climate Control

Centre console control panel



JAG0496NAS

1. Rear screen heat.
2. Temperature decrease, left-hand zone.
3. Temperature increase, left-hand zone.
4. Air recirculation and fresh air.
5. **AUTO** climate control knob.
6. Blower speed rotary control.
7. Temperature decrease, right-hand zone.
8. Temperature increase, right-hand zone.
9. Windshield defrost and demist.
10. Climate control main touch-screen.

Panel illumination

The illumination level is adjusted by the common instrument panel dimmer control, refer to page 140.

To switch the climate control on

With the ignition system ON, press the **AUTO** rotary control knob in the centre of the centre console control panel. The system will switch on in the auto operating mode. The control knob LED indicator will be illuminated.

Note: It is advisable to allow the system to stabilise before making large changes to the temperature setting, particularly at the start of a journey, refer to Temperature selection.

To switch the climate control off

The system can be turned OFF only from the options on the **Climate** touch-screen, see page 137.

Climate Control

AUTO mode

Automatic operation provides a controlled environment over a temperature range of 16°C to 28°C (59°F to 83°F) 17°C to 31°C (61°F to 89°F) and should be regarded as the normal operating mode.



To select automatic climate control press the **AUTO** button, the LED illuminates to confirm selection.

Select the required temperature.

Front and rear screen heating and timed air recirculation may be selected in **AUTO** mode. Selecting any other control will cancel **AUTO** operation. The control knob LED indicator will be extinguished.

Temperature selection



Separate controls allow the driver and passenger zone temperatures to be independently adjusted. Press the red buttons to increase temperature and the blue buttons to decrease temperature.

Both driver and passenger temperatures are displayed on the touch-screen.

Pressing the driver's buttons to select the maximum or minimum temperature settings causes the display to change to **HI** or **LO** respectively and cancel **AUTO** mode.

To quickly jump from **HI** or **LO** to a convenient mid range temperature of 22°C (72°F) 22°C (72°F), press and hold **AUTO** for a few seconds.

Air recirculation

Caution: Prolonged operation with recirculation selected and setting the automatic air recirculation sensor to a needlessly high level in cold and damp conditions, could result in interior screen misting.



Press the recirculation button to select air recirculation. Selection is indicated by the screen symbol and the button LED illuminating.

To deselect air recirculation, press the recirculation button again, or select **AUTO**.

Note: When air recirculation is selected, the sound of the airflow will change, this is normal.

Windshield defrost and demist



To remove frost or heavy misting from the windshield, press the **DEF** button.

- The blower switches on automatically at a high level speed but the speed can be adjusted manually if required.
- Air conditioning switches on automatically (to dehumidify the air) and cannot be deselected.
- Recirculation is cancelled and cannot be selected.
- The front screen heater and the rear screen heater and door mirror heaters switch on automatically, provided the engine is running.

Climate Control

- The button LED illuminates.

To deselect defrost mode, press **AUTO** or press the **DEF** button again.

Rear heated screen



The screen heater may be switched on and off in any mode, including system off, but only operates when the engine is running.

The rear screen and door mirror heaters switch off automatically after 21 minutes.

The screen heater may be manually deselected during the timed period using the push buttons.

In cold ambient conditions, at the start of a journey, the rear screen heater will switch on automatically for the timed period, it will come on below -1°C (30°F).

Air conditioning



Press the **AUTO** rotary control knob to turn the air conditioning on.

The air conditioning system is controlled automatically in **AUTO** mode to maintain the desired temperature and humidity (even if higher temperature settings are selected).

The air conditioning system is also switched on automatically in defrost mode (**DEF**) in order to dehumidify the air.

Blower speed



Set the blower speed as required by adjusting the **AUTO** rotary control knob.

When operating in **AUTO** mode, blower speed is controlled automatically and **AUTO** is displayed on the touch-screen. Any adjustment of the knob will cancel **AUTO** mode.

Note: In **AUTO** mode, the blower only operates at low speed, if heating is required, until the engine is warm.

Heated seats and steering wheel

The heated seats and steering wheel can be controlled only from the climate screen options on the touch-screen. See pages 61 and 63 respectively.

Touch-screen operation

The climate control touch-screen is controlled via the **Home** touch-screen.

Press the **Climate** button on the **Home** touch-screen.

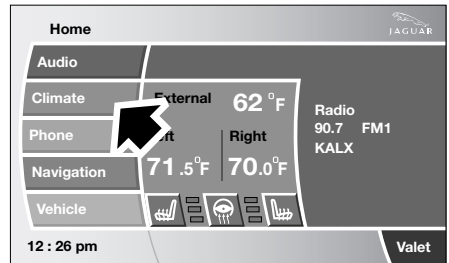

Climate Control

The climate control main view is displayed, from which the climate control settings can be set.



JAG0216NAS

Climate control display icons

The climate control display buttons and icons are as follows:

Auto

Auto climate control ON.



Distribution to windshield.



Distribution to face.



Distribution to feet.

Temp. sync.

Synchronizes the driver and passenger climate control zones.



Blower speed control decrease and increase.

Settings

Access to the Settings control touch-screen to adjust personal climate zone settings, also access to the automatic air recirculation sensor control setting.

Econ

Econ ON/OFF. Economy mode turns off the air conditioning compressor and reduces power consumed by the climate control system which will reduce air conditioning performance. Econ mode can be turned OFF only from the climate screen options on the touch-screen. Prolonged use may cause the windows to mist.

Climate 

Climate ON/OFF button.

External temperature

The external temperature is displayed at the top of the climate touch-screen zone.

Convertible Top

OPENING THE CONVERTIBLE TOP



WARNING:

- Before opening or closing the convertible top, ensure that all occupants have moved their hands, fingers, hair, etc. clear of moving parts.
- Do not place items on the tonneau panel or over the Rollover Protection Device covers.

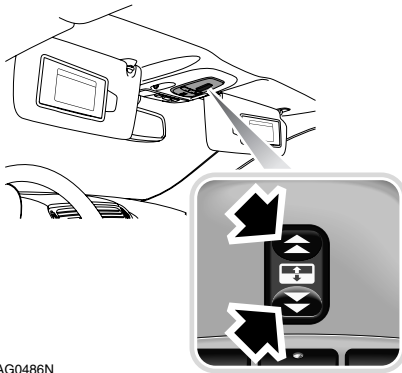

JAG0486N

The power operated convertible top and rear quarter windows, see page 88, are controlled by the switch located on the overhead console. The ignition system must be ON, see page 50. The top will latch and unlatch automatically. The top can be operated at speeds below 24 km/h (15 mph), however, for safety it should not be opened or closed when the vehicle is being driven.

Caution:

- The convertible top, will not operate unless the luggage separator is correctly located in the deployed position in the luggage compartment, see page 150 and that the luggage compartment lid is firmly closed.
 - Check that there is nothing in the rear area which could interfere with the top when folding down, e.g. ensure that the battery cover trim is fitted and secure.
 - Do not attempt to operate the convertible top at temperatures below -15°C (5°F). This may cause damage to the fabric.
 - If the convertible top is operated above 24km/h (15 mph) to excessive speeds there is a risk of damage to the convertible top.
 - Do not attempt to OPEN the convertible top manually, as damage to the linkage mechanism may occur.
1. Ensure that the ignition system is in the ON condition.
 2. Ensure that the luggage separator in the luggage compartment is in the fully deployed position. If it is not positioned correctly the proximity switches will not operate and the convertible top will not open, see page 151.

Convertible Top

3.

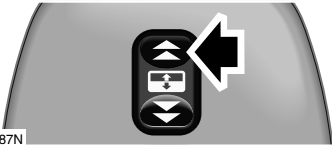

JAG00487N

Press and hold the rear of the overhead console switch. (Do not release the switch until the top is fully open.)

4.

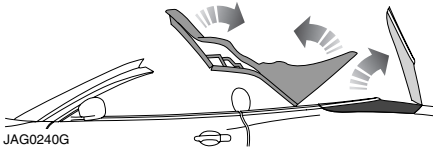

JAG0240G

The rear quarter windows open, an audible warning sounds, and the top unlatches and starts to move, the tonneau closing panel opens. (The front windows will fully open. The door window switch will require to be pressed to close the window.)

5.

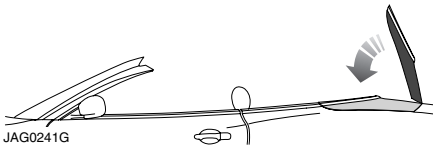

JAG0241G

When the top is fully open, the audible warning sounds again. The tonneau closing panel is fully automated and encloses the convertible top in the stowed position.

6. Release the overhead console switch.

Note: If at any period during the convertible top opening sequence the switch is released, all movement of the convertible top will cease.

Caution: Do not at any time during the opening or closing of the convertible top press the engine START/STOP button as all movement will cease and the convertible top will have to be manually re-set.

Convertible top manual re-set



WARNING: It is advisable that two persons carry out this procedure so that the convertible top and tonneau cover are fully supported when required; although it is possible that this procedure may be carried out by one person with care.

To manually re-set the convertible top:

Ensure that the engine is not running and that the ignition system is OFF.

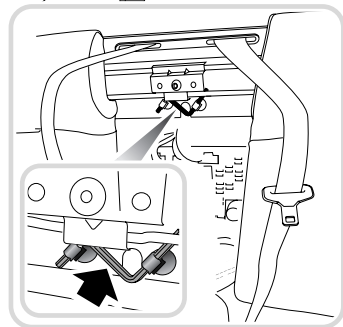
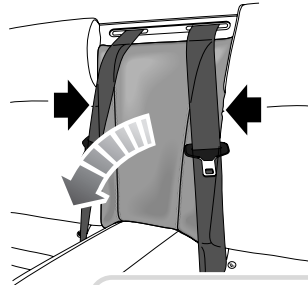

JAG0246G

Convertible Top

Grasp the sides of the section, as shown, and pulling sharply. Remove the Allen key from its stowed position.

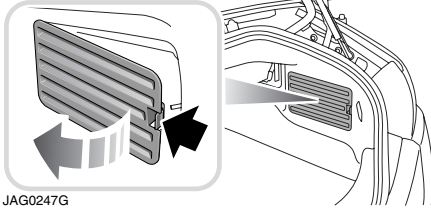

JAG0247G

From inside the luggage compartment, remove the vent screen to access the operating pump.

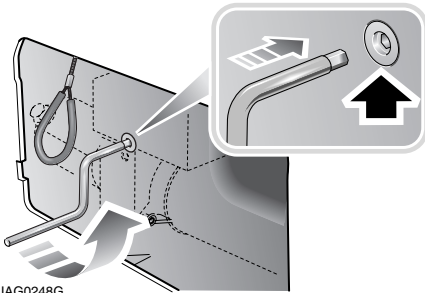

JAG0248G

Insert the Allen key into the pump and rotate counter clockwise (approximately one turn).

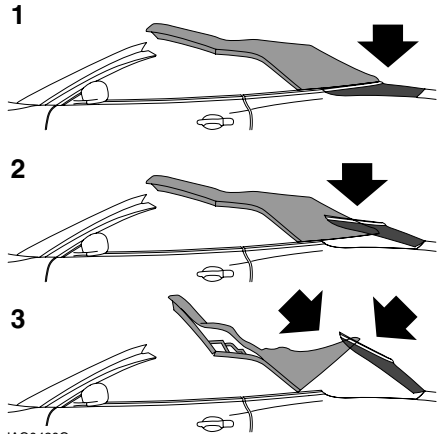

JAG0420G

The convertible top and tonneau cover movement can cease in any of the positions **1**, **2** or **3**, as shown.

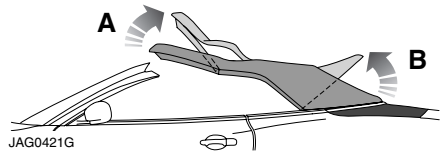

JAG0421G

If the movement ceases in position **1**, release the tension in the convertible top cover and tension bow (rear of convertible top) by lifting the front of the convertible top and pulling rearwards **A**.

Lift the tension bow upwards **B**, and forwards to clear the tonneau cover).

Convertible Top

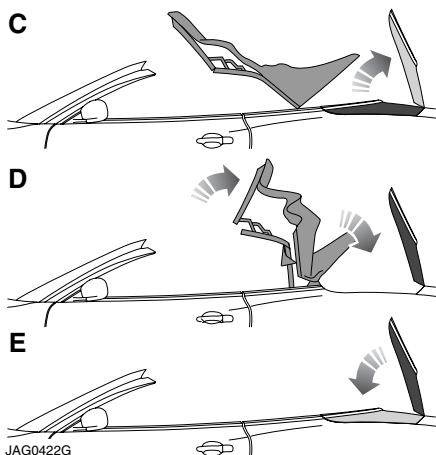

Lift the tonneau cover fully and support **C**. Pull the convertible top rearwards and downwards **D** so that it is fully stowed.

Rest the tonneau cover in the closed position **E**.

If the movement ceases in either positions **2** or **3**, lift the tonneau cover fully upright and support **C**, pull the front of the convertible top rearwards and downwards so that it is fully stowed **D**.

Rest the tonneau cover in the closed position **E**.

All positions: Turn the Allen key clockwise approximately one turn and return it to its stowed position, refit the rear seat centre section, luggage compartment vent screen and close the luggage compartment lid.

Switch ON the ignition system and start the engine. Press and hold the front of the convertible top switch until the convertible top is closed and fully latched.

If the convertible top requires to be open, press and hold the rear of the switch.

Preparation for Winter

Before the onset of Winter, it is advisable to coat the convertible top seals and respective body seals with a compound, such as Carbaflo KSP 105, to aid operation in freezing conditions.

This action will need to be repeated at the start of each Winter to maintain protection.

Care must be taken so that the compound does not come into contact with the convertible top material. For further advice you should contact your Jaguar Dealer.

Luggage separator

Caution: Luggage items should not be placed forward or on top of the luggage separator as it could cause damage to the separator.

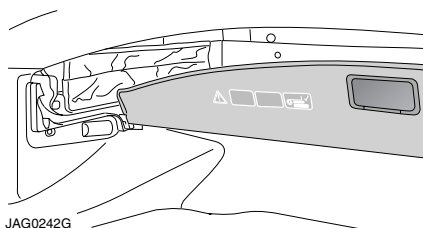

A luggage separator is located in the luggage compartment to prevent items from moving into the area where the convertible top is to be stowed.

When the convertible top is closed, the normal position for the luggage separator is in the retracted position with the partition positioned vertically.

Convertible Top

To deploy the luggage separator

Caution: Do not place large objects underneath the luggage separator partition when deployed as damage to the convertible top may occur.

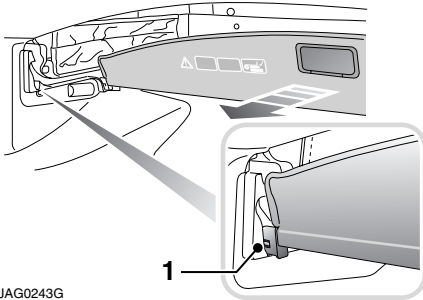

JAG0243G

Pull the handle on the luggage separator towards you. There is a lug on either side of the luggage separator: slide the lugs into the sliders on either side of the luggage compartment. The luggage separator will positively locate in the vertical position. A proximity switch, **1**, is located in the separator assembly so that the convertible top will not open and retract until the separator is in the fully deployed position.

When selected, if the convertible top does not open, the positioning of the luggage separator should be checked and ensure that the luggage compartment lid is firmly closed.

To remove the luggage separator

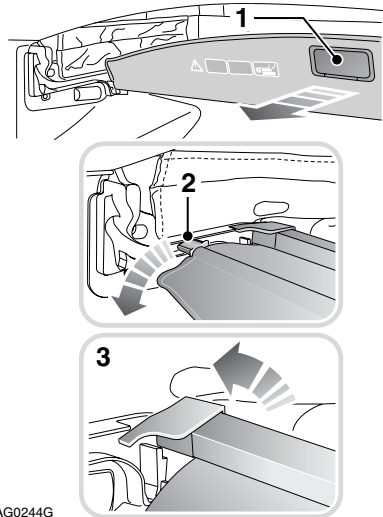

JAG0244G

With the luggage separator in the normally stowed position, pull the handle towards you, **1** and disengage the lugs from the sliders **2**.

Holding the centre of the main body of the luggage separator, rotate upwards **3**, disengaging the main body of the luggage separator from the support brackets. Remove the luggage separator and retract the withdrawn partition section of the luggage separator into the main body.

Convertible Top

To install the luggage separator

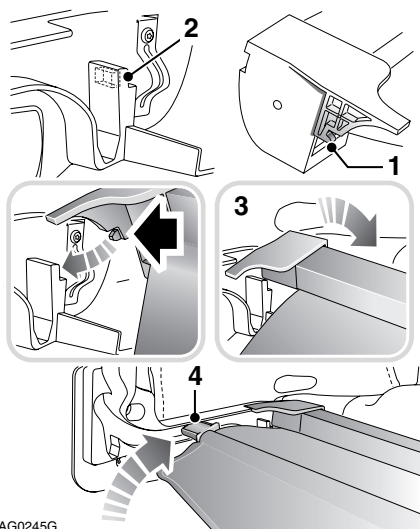

JAG0245G

With the partition slightly extracted, position the luggage separator up to the support brackets with the front edge raised. Ensuring, that for both sides, the catch **1** will engage in the locating slot **2**. Rotate the main body of the luggage separator **3** so that it sits down into the support brackets. Fit the partition lugs into the sliders **4** and retract the luggage separator partition into the normal stowage position.

CLOSING THE CONVERTIBLE TOP

1. Ensure that the ignition system is in the ON condition.
2. Press and hold the front of the overhead console switch, see page 147. (Do not release the switch until the convertible top is fully closed and latched, and if required the rear quarter windows and front door windows are fully closed.).
3. If the front windows are in any other position than fully down, they will retract to the fully down position on pressing the closure switch. As the convertible top starts to move the audible warning will sound.
4. When the top is fully closed and latched, the audible warning sounds again and the rear quarter windows will close followed by the front door windows returning to the fully closed position.

Note: *If at any period during the convertible top closure sequence the switch is released, all movement of the convertible top will cease.*

Convertible Top

Manual closure of the convertible top

If necessary, the convertible top can be closed manually, as follows:

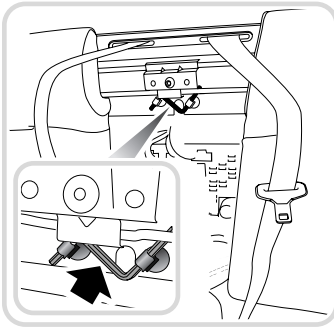
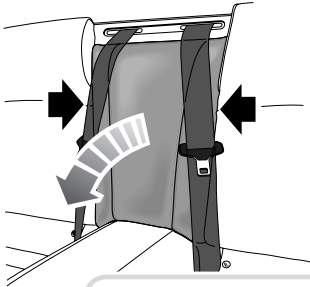

JAG0246G

Grasp the sides of the section, as shown, and pull sharply. Remove the Allen key from its stowed position.

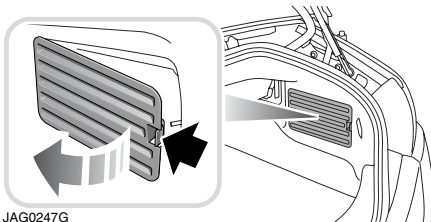

JAG0247G

From inside the luggage compartment, remove the vent screen to access the operating pump.

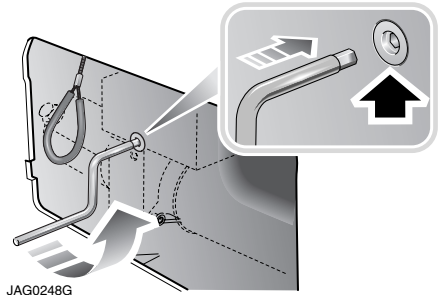

JAG0248G

Insert the Allen key into the pump and rotate counter clockwise (approximately one turn).

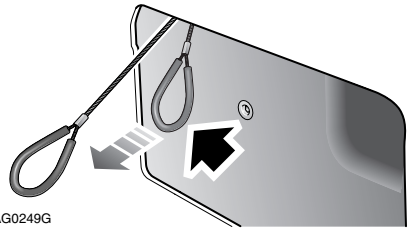

JAG0249G

Pull the tonneau release cable, until fully extended. Close the luggage compartment lid.

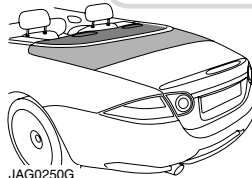
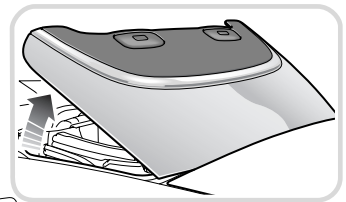

JAG0250G

Fully open the tonneau panel. It will self-support when fully opened.

Convertible Top

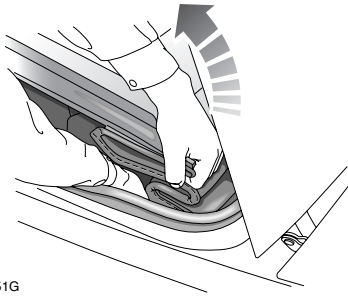

JAG0251G

From the left-hand side of the vehicle, place your right hand down the side of the folded convertible top. Ensure that the bottom of the convertible top, which includes the tension bow, is securely held. Securely hold the convertible top header assembly with your left hand. With both hands pull the whole of the convertible top up and forward.

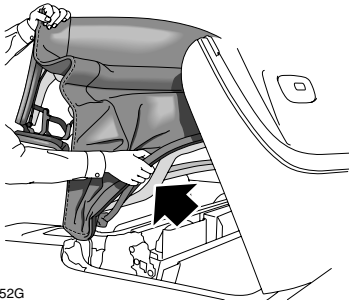

JAG0252G

Ensure that the tension bow is fully raised.

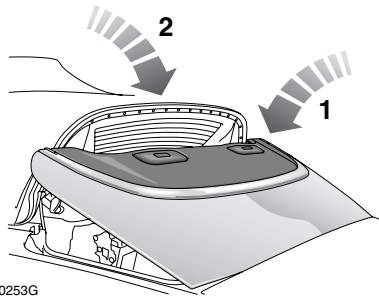

JAG0253G

Supporting the tension bow, lower the tonneau panel **1**. Then lower the tension bow **2** onto the tonneau panel.

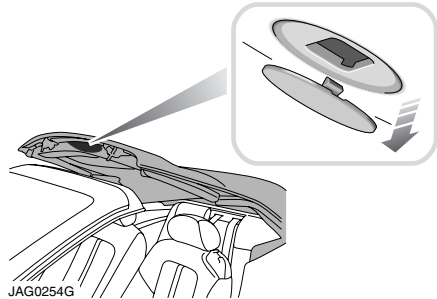

JAG0254G

Remove the plug from the convertible top header trim.

Convertible Top

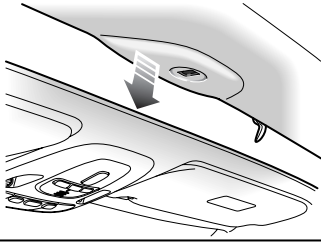

Support the front header. Insert the Allen key into the header panel key slot and turn clockwise until the top is securely latched and resistance is felt.

Return the Allen key to its stowed position, refit the rear seat centre section, luggage compartment vent screen and the plug into the convertible top header trim.

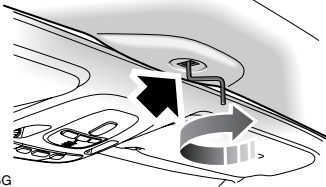

JAG0255G

Message centre information displays

Message	Warning Light	Priority Indicator	Meaning
HOOD NOT LATCHED	None	Red	The convertible roof is not latched, check for security.
HOOD OUT OF POSITION	None	Amber	The convertible roof is not correctly positioned. Open or close the convertible roof again and check for correct positioning.
LUGGAGE COVER OUT OF POSITION	None	Amber	The luggage separator is out of position and should be checked, see page 152.

Load Carrying

GENERAL INFORMATION



WARNING:

- (Coupe only): Extreme care must be taken when closing the luggage compartment lid when passengers are travelling in the rear seats.
- Locate heavy loads in the luggage compartment towards the front of the vehicle and secure them to stop them sliding. Loose items can be a hazard.
- Do not drive with the luggage compartment open as exhaust fumes can be drawn into the passenger compartment.

To prevent permanent damage to the luggage compartment trim, it is advisable to distribute luggage weight evenly over the entire luggage floor area.

LUGGAGE COVER

(Coupe only)

Caution: It is advisable that items are not placed on the luggage cover.

The luggage cover is removed by releasing the two latches **1** on either side of the luggage cover and sliding it downwards and forwards so that the rear locating pegs **2** are disengaged from the trim and body. This will allow the luggage cover to be completely removed.

To refit the luggage cover first locate the rear pegs **2**. Then from the side of the vehicle, support the luggage cover and fit the front catch **1**, by pressing it firmly through the cover and closing the catch, this will hold the luggage cover in place. Repeat this procedure on the other side of the vehicle.

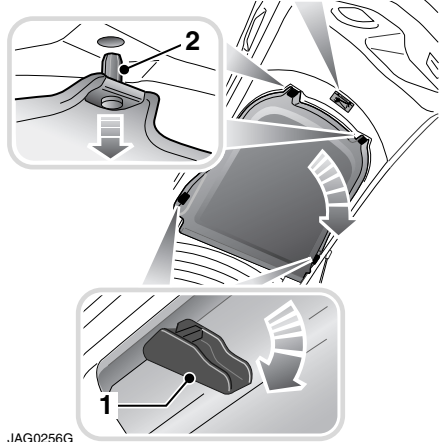
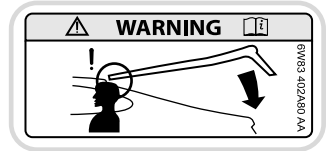

JAG0256G

Transmission

AUTOMATIC TRANSMISSION

The transmission system is designed to operate in two distinct modes, conventional automatic and **Jaguar Sequential Shift**.

The automatic modes are accessed by the gear selector:

- **D** - Drive - automatic shifting.
- **S** - Sport - sport automatic shifting.

The **Jaguar Sequential Shift** mode enables sequential manual gear selection in **D** (temporary) and **S** (permanent) modes via the steering wheel mounted paddles.

Note: In addition to the standard shift patterns available in **D** and **S**, the transmission will adapt to differing driving conditions by modifying shift points based upon vehicle sensor information for road gradient, cornering, braking pressure and driving style.

Gearshift interlock



WARNING:

The brake pedal must be applied before selecting forward or reverse drive from a stationary position.

A brake pedal and gearshift interlock system is incorporated in the automatic gear selector mechanism.

To move the gear selector from Park:

1. Ensure the ignition system is in the **convenience mode** or start the engine.
2. Press the brake pedal.

Gear selection and message centre indication

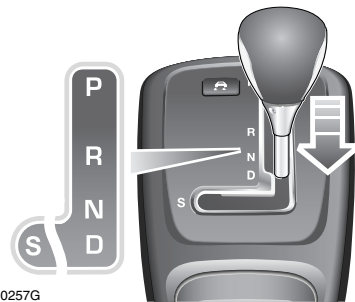

JAG0257G

The message centre indicates the position of the gear selector at the top of the message centre screen. When automatic selection is made the screen indicates either **P**, **R**, **N** or **D**, **1**. When **S** is selected the indication changes to **DS**, **2** and if manual selection is made the indication is from **1** to **6**, **3**.

P = Park – Use when parked. In this position the transmission is locked. Do not select if the vehicle is moving.

R = Reverse – Do not select if the vehicle is moving forward.

Transmission

N = Neutral – Disconnects drive to the wheels. Use the parkbrake when stopping temporarily.

D = Drive – All six forward gears are changed automatically.

S = Sport – All six forward gears are changed automatically with modified gear shift points.

Stationary vehicle

When the vehicle is stationary the gear selector may be left in **D**, or **S**, unless the vehicle is to be parked. When stopping for extended periods, either select **P** or apply the parkbrake and select **N**.

Shift inhibit

Reverse is inhibited when the vehicle is moving forward.

Note: Reverse inhibit will not function in limp-home mode.

Note:

- The engine is limited to a maximum speed of 4 500 rev/min. when **N** or **P** is selected.
- After selecting forward or reverse drive ranges from **N** or **P**, wait briefly for the transmission to engage before accelerating.

Automatic operating modes

There are two available automatic modes:

D - Drive: All six gears are changed automatically. The shift points are determined by accelerator pedal position and road speed to provide the best balance of performance, refinement and fuel economy for the large majority of driving conditions.

S - Sport: The transmission operates automatically, but the gearshift points are modified to maximise the vehicle response in demanding driving conditions. This mode is not suitable for town or highway cruising.

The automatic modes also offer additional features:

Kick-down: Is operated when the accelerator pedal is fully depressed beyond the normal operating spring pressure to provide maximum engine performance. Kick-down is used in circumstances where rapid acceleration is required, such as when overtaking.

Kick-down causes the transmission to change down to the lowest gear possible to achieve maximum acceleration. The gear engaged depends on the road speed at the time of kickdown.

Driver type recognition: The transmission monitors driving style and in combination with sensors in the vehicle, varies the shift schedule, fast-off, corner recognition and shift adapt under braking functions proportionally with driving style.

Note: This feature is only active in **S - Sport** mode.

Fast-off: Activated when rapidly lifting-off the accelerator pedal and takes account of road gradient. This feature inhibits up-shifts enhancing performance.

Note: This feature will vary its activation, dependant upon the driver type if **S - Sport** is selected.

Transmission

Shift adapt under braking: Under braking, the transmission will vary the down-shift point in proportion to braking effort and road gradient. This feature is realised in conjunction with positive torque, resulting in a smoother down-shift.

Note: *This feature will vary its activation, dependant upon the driver type if **S** - Sport is selected.*

Positive torque: Provides throttle blips on down-shifts under braking, improving shift feel.

Note: *This feature is only active in **S** - Sport mode.*

Corner recognition: Inhibits up-shifts during cornering to provide improved vehicle balance.

Note: *This feature will vary its activation, dependant upon the driver type if **S** - Sport is selected.*

Road gradient adaption: When the vehicle is being driven on roads with uphill gradients, the transmission adapts the shift pattern to make better use of engine power.

When driving on roads with long downhill gradients, the transmission may automatically select a lower gear to increase engine braking. Selecting **S** will increase the tendency of the transmission to select a lower gear in these conditions, further increasing engine braking.

Note: *It is also possible to manually select a lower gear to increase engine braking via use of the shift paddles.*

Cruise control: When cruise control is active, the transmission selects a shift pattern to suit cruise control operation, see page 169.

Dynamic stability control (DSC): When DSC is switched ON and the system is activated, the transmission selects a shift pattern to suit traction control conditions.

Manual operating modes - Jaguar Sequential Shift

Shifts in the **Jaguar Sequential Shift** manual mode are optimised to provide a rapid response to gear shift requests. Up-shift requests are optimised for performance via the short shift function, this will result in a firmer shift feel than in automatic modes. Down-shift requests realise a throttle blip during the shift event resulting in improved shift feel.

The **Jaguar Sequential Shift** modes can be accessed either temporarily or permanently.

Temporary manual gear selection:

When the gear selector is in the **D** position, manual mode may be directly accessed by the single action of operating the steering wheel mounted shift paddles.

This convenience feature allows immediate but temporary use of the shift paddles whilst the gear selector is in **D**.

If continued use of manual mode is required, the gear selector may be subsequently moved to the **S** position to enter permanent manual mode in the currently selected gear.

If the gear selector remains in the **D** position, temporary manual mode will be held whilst the driver is accelerating, decelerating, cornering or continuing to request shifts via the paddles.

Transmission

The transmission will revert to automatic operation after a short period of driving at steady speed; alternatively the shift-up (+) paddle may be held for a short period (approximately one second) to return directly to automatic operation in **D**.



Permanent manual gear selection:

Select the **S** position, permanent manual mode then is accessed by the operation of the steering wheel mounted shift paddles.

The message centre will highlight the currently selected gear.

To exit from the **Jaguar Sequential Shift** permanent manual mode, move the gear selector to the **D** position. The transmission will revert to the **D** automatic shift mode.

Manual operation

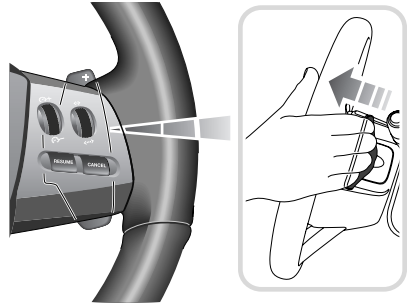

To shift-up, briefly pull the shift-up (+) paddle on the right-hand side of the steering wheel towards you.

To shift-down, briefly pull the shift-down (-) paddle on the left-hand side of the steering wheel towards you.

The message centre display will change to highlight the requested gear.

Note: The transmission will inhibit up-shifts and down-shifts if the requested shift would result in an engine speed outside the normal operating range of the engine. If this occurs, the message centre will briefly display the requested gear selection, but will return to displaying the current gear.

Transmission

The **Jaguar Sequential Shift** mode also has the following features:

Kick-down: Operation of kick-down in **Jaguar Sequential Shift** mode will over-ride the currently selected gear. The lowest available gear will be selected for maximum acceleration and will be highlighted in the message centre display. Subsequent manual shifts may then be selected as usual.

Positive torque: Provides throttle blips on down-shifts, improving shift feel and response.

Shift assist: The transmission will automatically up-shift at the engine speed redline in **Jaguar Sequential Shift** mode as if commanded manually.

The transmission will automatically down-shift when the engine rpm drops too low for the currently selected gear.

When the vehicle approaches, or comes to rest, second gear is automatically selected.

Subsequent pullaways will occur in second gear, unless the accelerator pedal demand is high or a down-shift is manually selected, in which case, first gear will be selected.

In all cases the message centre will display the current gear.

Note: *If a down-shift is requested which would normally result in an engine speed outside the normal operating range during **sustained braking** the transmission will indicate and hold the requested gear in the message centre display. The transmission will then commence the down-shift when the engine speed is within the normal operating speed.*

Limp-home mode



WARNING:

The driver should be aware that the vehicle's performance will be reduced and must take this into account when driving. Also the use of the Jaguar Sequential Shift paddles will be disabled. In this event consult a Jaguar Dealer immediately.

In the unlikely event of an electrical or mechanical failure, transmission operation will be limited. The vehicle gear selector ranges **P, R, N, D** can still be used to enable the vehicle to be driven to a safe area.

Message centre display

The message centre may display the following messages with associated warning indicators:

ENGINE SYSTEMS FAULT (Red)

RESTRICTED PERFORMANCE (Red or Amber)

TRANSMISSION FAULT (Amber)

If any of these messages are displayed it is likely that loss of power or driveability will be experienced. Seek qualified assistance as soon as possible.

Final drive unit

Caution: **Although the final drive unit is a fill for life unit, if your vehicle is used for a race event or test track day, then following the event the final drive unit lubricant should be changed. Contact your Jaguar Dealer.**

Brakes

PRINCIPLE OF OPERATION

Anti-lock braking system (ABS)



WARNING:

- **It remains the driver's responsibility to drive safely according to prevailing conditions.**
- **The fact that a vehicle is fitted with ABS must never allow the driver to be tempted into taking risks which could affect his or her safety or that of other road users.**
- **The addition of ABS cannot overcome the consequences of trying to stop in too short a distance, cornering at too high a speed, or the risk of aquaplaning.**
- **The driver should always take road conditions into account. A slippery road surface always requires more braking distance for a given speed, even with ABS. A possible increase in stopping distance compared to locked wheels may occur during ABS operation on slushy snow, gravel, sand, or some heavily corrugated or ridged warning sections of road surfaces.**

This system helps to prevent the road wheels from locking and skidding during emergency braking, assisting the driver to maintain full steering and directional stability.

The factor controlling ultimate stopping distance and cornering ability is tire and road adhesion.

ABS optimises tire to road adhesion under maximum braking conditions though it cannot provide increased cornering ability.

During normal braking the ABS will not be activated. However, if the braking force applied begins to exceed tire to road adhesion the ABS will automatically activate, preventing the road wheels from locking.

In these circumstances a pulsating effect will be felt from the brake pedal indicating that the system is functioning. The pulsating effect is due to small fluctuations in pressure supplied to the brakes by the system to maintain full tire and road adhesion.

Under severe braking on some road surfaces tire noise may be apparent even though the wheels will at no time become locked.

ABS monitoring

Caution: Consult a Jaguar Dealer immediately if the warning light comes on while driving, a system failure is indicated.

The ABS control module monitors the ABS electrical system from ignition switch ON to ignition system OFF. Any malfunction will be indicated by the anti-lock warning light coming on and a message **ABS FAULT** will be displayed by the message centre.

Should a fault develop in the ABS system, the brake system will still operate conventionally and with the same standard of performance as vehicles not equipped with ABS.

Brakes

Emergency Brake Assist (EBA)



WARNING:

The EBA system is an additional safety system; it is not intended to relieve the driver of his or her responsibility for exercising due care and attention when driving.

The EBA system measures the rate at which the brake pressure increases. If the system detects an emergency braking situation, EBA automatically initiates the full braking effect. This can reduce stopping distances in critical situations, which can help an inexperienced driver to stop in the same distance as an experienced driver.

Any malfunction will be indicated by the message **BRAKE ASSIST FAULT** displayed by the message centre. Increased brake pedal effort may be required to slow the vehicle. Seek qualified assistance as soon as possible.

HINTS ON DRIVING WITH ABS

For optimum ABS performance these instructions on braking techniques during ABS operation should be followed:

- Do not release brake pressure when the pulsating effect is felt. Maintain a constant pressure until the manoeuvre is completed.
- To familiarise yourself with the feel of the brake pedal during ABS braking, practise an emergency stop procedure, always making sure it is safe to do so. With the seat belts fitted to all occupants, drive the vehicle at 32 km/h (20 mph) and brake sharply.
- ABS enables the driver to steer around obstacles during emergency braking. However, the consequences of turning sharply at high speed cannot be overcome by the ABS.
- Do not attempt to pump the brakes to avoid skidding as this can interfere with the ABS operation. The ABS will not allow the wheels to skid under normal road conditions.
- The ABS will tend to keep the vehicle straight during braking. Because braking distances may increase under certain road conditions, it is necessary to plan and make turning manoeuvres as early as possible.

Brakes

ELECTRIC PARKING BRAKE (EPB)

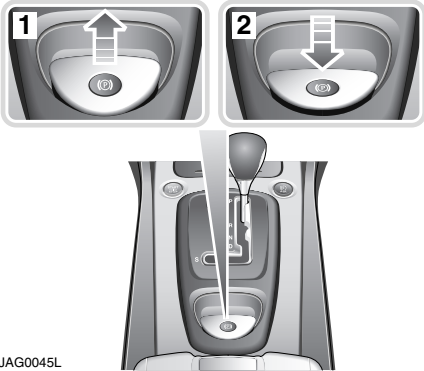

JAG0045L

The switch which operates the parkbrake is mounted on the centre console to the rear of the gear selector.

To engage the parkbrake 1: Pull the parkbrake switch upwards and release. The switch will return to the neutral position. The parkbrake warning/brake fluid low warning light on the instrument cluster will illuminate.

The Drive Away Release feature allows the parkbrake to release automatically as the vehicle is driven away.

To disengage the parkbrake 2: With the ignition system in the ON position or with the engine running, apply the foot brake and press the parkbrake switch down.

If the parkbrake is applied while the vehicle is stationary and **D** or **R** is selected, applying the throttle will automatically release the parkbrake.

The parkbrake is also automatically released when the gear selector is moved from the **P** position.

Inadvertent operation of the parkbrake whilst the vehicle is in motion, above 3 km/h (1.8 mph), will cause the message **PARK BRAKE APPLIED** to be displayed on the message centre, the warning light in the instrument cluster will be illuminated and a warning chime will sound.

If the parkbrake is applied whilst the vehicle is moving, releasing the switch will disengage the parkbrake. The parkbrake cannot be applied whilst the vehicle is moving and the throttle pressed.

Note: *If the vehicle is in motion, the parkbrake should only be used as an emergency brake.*

Caution: **Take care that the vehicle is safely parked to prevent it from rolling if you wish to leave the parkbrake off. However, it is advisable to always use the parkbrake.**

The warning light in the instrument cluster will remain on for a short time if the parkbrake is applied when the ignition system is reverted to the **convenience mode**, see page 42.

If a fault in the system is detected, a message **PARK BRAKE FAULT** or **CANNOT APPLY PARK BRAKE** will be displayed. Seek qualified assistance as soon as possible.

If the battery has been discharged or disconnected a message **APPLYFOOT AND PARKBRAKE** will be displayed when the ignition is next switched on. Depress the footbrake and pull the parkbrake switch up to apply the parkbrake. This is required to reset the parkbrake system. The parkbrake will now function correctly.

Stability Control

PRINCIPLE OF OPERATION

Dynamic stability control (DSC)



WARNING:

The fact that the vehicle is fitted with DSC must never allow the driver to be tempted into taking risks which could affect his/her safety or that of other road users. In all cases it remains the driver's responsibility to drive safely according to the prevailing conditions.

Dynamic stability control is operational whenever the engine is running, unless it has been switched off. When the system is operating, the warning light in the instrument cluster will flash.

The DSC system controls the anti-lock braking system (ABS), traction control and yaw control of the vehicle.

The DSC system assists the driver in retaining directional control of the vehicle in situations where the vehicle is sliding (understeer or oversteer). It must not encourage the driver to drive beyond the limit of adhesion or at speeds higher than those suitable for the prevailing road and traffic conditions.

It applies braking pressure to individual wheels if excessive variation is detected. This ensures that the vehicle follows the driver's intended direction of travel.

Traction control will intervene to prevent wheel spin by automatically reducing the power output from the engine and applying braking to individual wheels. This improves acceleration, particularly on surfaces with uneven friction, for example, one wheel on ice the other on tarmac.

Trac dynamic stability control (Trac DSC)

Trac DSC is an additional feature where DSC settings are optimised for maximum traction in difficult conditions, such as deep snow, sand or gravel. This makes greater traction possible, without having to completely lose the benefits of DSC, however, vehicle stability may be reduced.

Caution: Vehicle safety could be reduced by inappropriate use of Trac DSC. Trac DSC should only be used when necessary for the prevailing conditions:

- **In deep snow.**
- **To maintain the movement of the vehicle on soft or loose surfaces e.g. gravel, sand.**
- **When snow chains are fitted.**

Stability Control

USING STABILITY CONTROL

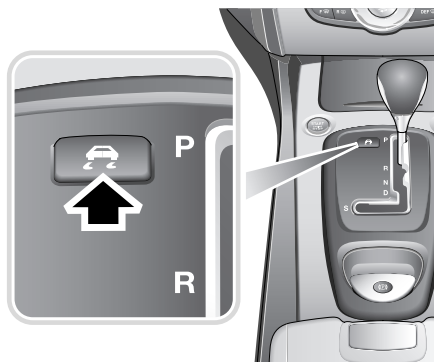

JAG0262L

Switching between DSC and Trac DSC - All vehicles

- Press and hold the DSC switch for less than three seconds.
- The message centre will temporarily display either **Trac DSC** or **DSC ON**.
- The warning light on the instrument cluster will illuminate while Trac DSC is selected.
- The warning light will flash when DSC or Trac DSC is active.

Note: If cruise control is engaged it will automatically disengage if stability control activates.

Switching between DSC OFF and ON - Normally aspirated engines only

Switching DSC OFF:

- Press and hold the DSC switch for more than three seconds.
- The message centre will temporarily display **DSC OFF** and a warning chime will sound.
- The warning light on the instrument cluster will illuminate.

Switching DSC ON:

If DSC is OFF:

- Press and release the DSC switch.
- The DSC system will switch on, the message centre will temporarily display **DSC ON**.
- The warning light on the instrument cluster will be extinguished.

Stability control indicator - All vehicles

A system malfunction is indicated by the message **DSC NOT AVAILABLE** in the message centre and the amber priority warning light. The instrument cluster warning light will also be lit.

It is safe to drive the vehicle but the DSC system will not activate under wheel spin or slide conditions. You should seek qualified assistance as soon as possible.

Computer active technology system (CATS)

If the message centre displays the message CATS SYSTEM FAULT, a fault has been detected in the adaptive damping system. Seek qualified assistance as soon as possible.

Parking Aid

PRINCIPLE OF OPERATION



WARNING:

- It remains the driver's responsibility to be vigilant when reversing. Small children or animals may not be detected by the system.
- It remains the driver's responsibility to detect obstacles and estimate the car's distance from them. Some overhanging objects, barriers, thin obstructions or painted surfaces which could possibly cause damage to the vehicle may not be detected by the system. Always be vigilant when reversing.

Caution:

- Once the system has been activated by selecting reverse or using the switch, the rear sensors are active when the gear selector is in neutral. Therefore, if an obstacle is detected a tone will sound.
- Objects moving away from the vehicle will be reported. However, whilst driving away, object warning may be temporarily reported due to ground reflection.

The Park Assist System is automatically in standby when the ignition is turned on.

USING THE PARKING AID

Touch-screen

To set the preferences of the parking assist, the settings are accessed via the touch-screen **Home** screen and **Veh. settings**.

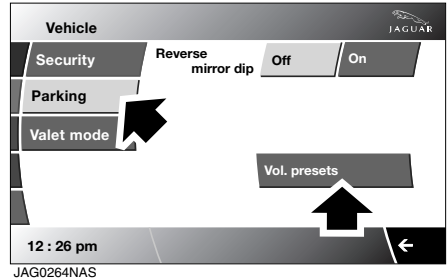

Select **Parking (1)**.

There is a link to **Vol. presets** in order that the volume of the parking assist warning beeps may be adjusted.

Note: *The volume adjusts both front and rear speaker volume.*

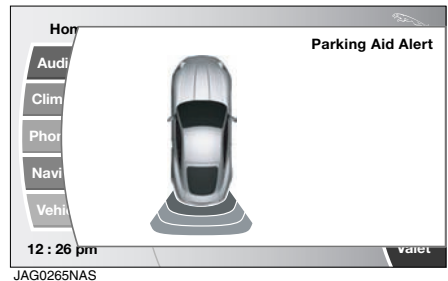

When the reverse parking aid is active, a pop-up screen is initiated displaying the area of the vehicle. This can be cancelled by touching the screen within the pop-up area.

Parking Aid

Rear parking aid

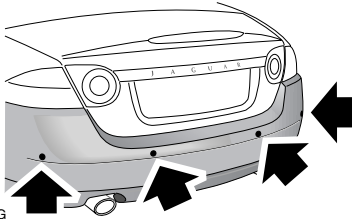

JAG0267G

When reverse gear is selected and the ignition is on, if obstacles are detected within operating range, as shown in the illustration below, the rear parking assist automatically provides an audible proximately warning to the nearest detected object.

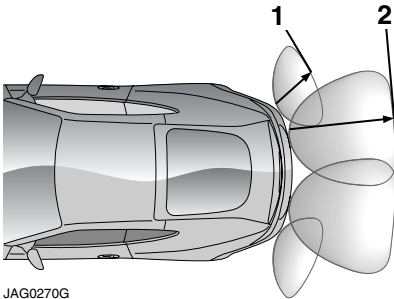

JAG0270G

1 is approximately 60 cm (24 inches).

2 is approximately 180 cm (71 inches).

The beep tone increases in rate as the vehicle approaches the obstacle.

The rear parking assist beep will become continuous when the obstacle is detected at or within 30 cm (12 inches) from the vehicle.

Note: The outer rear sensors **1** will show visual detection on the message centre before the audible warning is given.

Rear fitted accessories

Particular care must be taken when reversing with rear fitted accessories e.g. bicycle carrier, as the rear park assist will only indicate the distance from the bumper to the obstacle.

System Fault

The parking assist may sound spurious tones if it detects a frequency tone using the same band as the sensors.

Cleaning the Sensors

Do not clean the sensors with abrasive or sharp objects or materials.

For reliable operation, the sensors in the rear bumpers should be kept free from ice, frost and grime.

When using a high pressure spray the sensors should only be sprayed briefly and not from a distance of less than 20 cm (8 inches).

Cruise Control

PRINCIPLE OF OPERATION

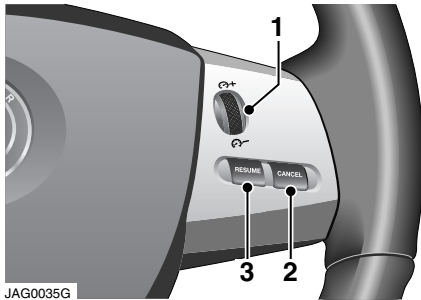

The cruise (speed) control system can be used by the driver to maintain a selected vehicle speed above 30 km/h (18mph) without the driver having to use the accelerator.

Adjustment controls on the steering wheel allow the driver manual control of the system. Brake and clutch operations also influence the cruise control system.

SPEED ADJUSTMENT CONTROL 1

thumb wheel is used to engage cruise control initially by rolling it upwards. It is also used to increase or decrease the set speed.

CANCEL 2 cancels cruise control but retains the set speed in memory.

RESUME 3 engages cruise control after it has been cancelled.

USING THE CRUISE CONTROL

Setting vehicle speed



WARNING:

Only use cruise control when conditions are favourable, for example, straight, dry, open roads with light traffic.

When you are travelling at the speed you require, which must be above 30 km/h (18 mph), roll the speed adjustment control 1 upwards or downwards to increase or decrease speed.

Cruise control will engage and maintain the set speed and you can remove your foot from the accelerator pedal.

Note: Cruise control will automatically disengage when the brake pedal is pressed or when the vehicle speed falls below 30 km/h (18 mph).

Changing the speed

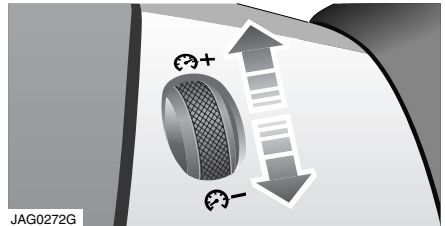

There are two ways to change the set speed:

- Accelerate or decelerate to the desired speed then roll the speed adjustment control upwards (+).
- Increase or decrease the speed by rolling the speed adjustment control upwards (+) or downwards (-) until the desired speed is obtained.

Cruise Control

Note: The set speed can be increase or decrease the speed in steps of 1 mph (2 km/h) by rolling the speed adjustment control upwards (+) or downwards (-) briefly until the desired speed is obtained.

Resuming the speed

If the vehicle is accelerated above the set speed, then the set speed will be resumed when the accelerator pedal is released.

If **CANCEL** is pressed, or the brake pedal is pressed, the cruise control will disengage but the set speed memory will be retained. Press **RESUME** and the vehicle will return to the set speed.

Note: *Cruise control will not resume at speeds below 30 km/h (18 mph).*

RESUME will not operate if the ignition has been turned OFF.

Caution:

- **RESUME should only be used if the driver is aware of the set speed and intends to return to it.**
- **It is not recommended to resume set speed when a low gear is selected as excessive engine speeds will occur.**

Cruise control will switch OFF and clear the memory when:

- The ignition system is switched OFF.
- A fault occurs. The cruise control system will switch OFF and cannot be used until the fault is cleared.

Automatic switch off

Cruise control will switch off but the set speed will remain in the memory when:

- The **CANCEL** button is pressed.
- The brake pedal is pressed.
- Speed falls below 30 km/h (18 mph).
- Neutral, Park or Reverse gear positions are selected.
- Dynamic stability control is operating.
- The difference between the actual and set speed is too great.
- When the vehicle reaches a maximum speed of 192 km/h (120 mph).
- The accelerator pedal is used to accelerate beyond the set speed for too long a period.

Cruise Control

Message centre information displays

Message	Warning Light	Priority Indicator	Meaning
CRUISE ENGAGED	None	None	Displayed when cruise control system is operating.
CRUISE OVERRIDE	None	None	Driver is pressing the accelerator pedal overriding cruise control function. Message will disappear when accelerator pedal is released and cruise control speed is resumed.
CRUISE CANCELLED	None	None	Driver has cancelled cruise control or is braking.
CRUISE NOT AVAILABLE	None	None	Cruise control or adaptive cruise control malfunction.

Automatic Speed Limiter (ASL)

PRINCIPLE OF OPERATION



WARNING:

Automatic Speed Limiter (ASL) set speeds must be within local speed restriction limits. The driver must always ensure that a safe speed is set, taking into account the prevailing traffic and road conditions.

ASL can be used in a situation where varying vehicle speed is likely but a maximum speed must not be exceeded.

For example, where a local speed limit is 80km/h (50mph), the set speed could be at that limit or just under. The driver is then safe in the knowledge that the local speed limit cannot be exceeded while ASL is operating.

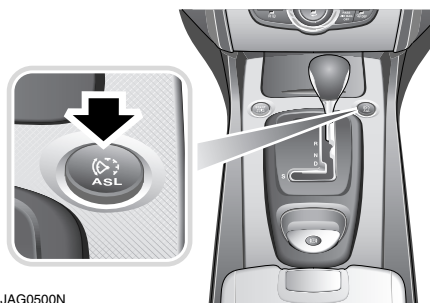

JAG0500N

If ASL is not selected, cruise control is always available by simply rotating the thumb wheel on the right hand side of the steering wheel to set a cruising speed. The **ASL** button allows the driver to select between cruise control and the automatic speed limiter. The ASL can be set to any speed between 30km/h (18mph) and 240 km/h (150 mph).

When ASL is selected, the instrument panel telltale status light will illuminate. When the ASL button is pressed again, the light will extinguish, ASL will be cancelled and cruise control will be available again.

USING THE ASL

Setting a speed limit

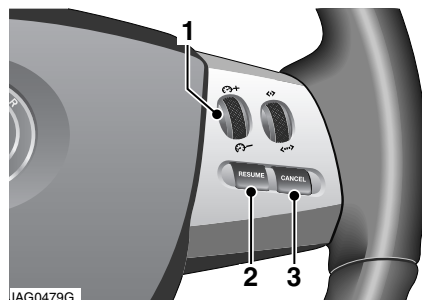

JAG0479G

1. Press the **ASL** button.
2. Use the thumb wheel **1** to set the required speed.
While a speed is being set or altered the message centre display in the instrument panel will show the selected speed.
3. The set speed can be adjusted at any time by rotating the thumb wheel **1**.

**LIMITER SET
XXX MPH**

Note: The message is also displayed at other times as an information display.

Automatic Speed Limiter (ASL)

When ASL is selected and a set speed inserted, the engine will respond normally up to the set speed. Further accelerator pedal pressure will not increase the vehicle speed beyond your set speed

Suspending ASL

ASL can be suspended by pressing the **CANCEL** button **3**. Applying sudden, rapid acceleration (kickdown) will also suspend ASL.

**LIMITER
CANCELLED**

Resuming ASL

If ASL has been suspended, it can be reinstated with a single press of the **RESUME** button **2**, however, ASL will only reinstate if the vehicle speed is less than the current speed set in memory and greater than 30km/h (18mph). The message centre will display an appropriate message if the vehicle speed is too fast to resume ASL.

**TOO FAST TO
RESUME**

Exceeding the set speed

If the set speed is exceeded, e.g. on a steep downhill section, the message centre will display an appropriate message along with an amber warning light.

**OVER LIMIT
XXX MPH**

There are three categories of over limit displays:

1. If the set speed is exceeded by up to 15km/h (9mph), the message centre will display the message along with an amber warning light
2. If the set speed is exceeded by more than 15km/h (9mph), the message centre will display the message along with a flashing amber warning light.
3. If the set speed is exceeded by more than 15km/h (9mph) for a duration of five seconds, the message centre will display the message along with a flashing amber warning light and also give an audible warning tone.

Use your brakes to rectify the situation.

ASL unavailable

If ASL is not available due to a fault, the message centre will display an appropriate message along with an amber warning light.

**LIMITER NOT
AVAILABLE**

The message and warning light will display continuously while ASL is selected. See Information Displays, page 118.

When the ignition is switched off, ASL is deactivated and any set speed is deleted from memory.

Audio

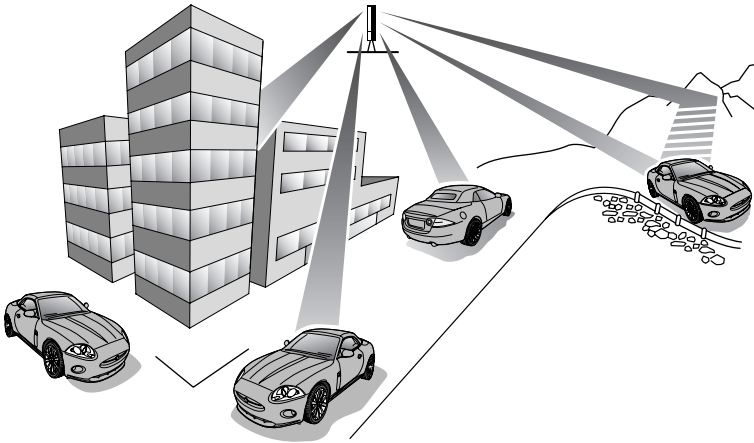

JAG0282G

RADIO RECEPTION

Your radio receives signals whilst on the move, and may experience widely differing reception characteristics. Because of this, some interference is to be expected from time to time during a journey.

FM transmitters can only broadcast over a limited range, and good clear signals will only be received in the immediate area of the transmitter. When travelling, occasionally it may be necessary to re-tune the radio to offset the effects of moving from one transmitter area to another.

While automatic re-tuning helps to reduce the effects of signal changes, some manual re-tuning may still be required (especially for local stations) in areas of weak reception.

The broadcast range for good stereo reception is within approximately 48 - 64 km (30 - 40 miles) of the transmitter.

FM Signals travel in a straight line, so large obstacles, such as tall buildings, can shield the car from the signal causing distortion or loss of reception (known as dead spots).

Distortion can also occur if FM signals received directly from the transmitter, mix with signals deflected by obstructions such as mountains, hills, and tall buildings. This is known as multi-path distortion.

Note: *Although distortion, interference and lack of signal clarity are sometimes attributed to a fault in the radio, this is rarely the case.*

Audio

GENERAL INFORMATION

The sound system is available in two versions:

The Jaguar Sound System comprises a radio and in-dash 6 compact disc (CD) player and door mounted speakers and additional speakers in rear quarters.

The Jaguar Premium Surround Sound System comprises a radio and in-dash 6 compact disc (CD) player, with upgraded speakers mounted in the doors and rear quarters, plus an additional speaker mounted in the fascia and a sub-woofer mounted in the passenger foot well under the carpet.

This speaker configuration allows the reproduction of audio in stereo, 3-channel or Dolby Pro Logic II Surround Sound.

The audio system can be controlled from the switches on the touch-screen console, the touch-screen buttons and from the multi-function controls on the left-hand side of the steering wheel. These controls are described in the **Steering Wheel** section on page 64.

Audio system care

Caution:

- **Care must be taken to avoid spilling or splashing drinks onto the audio unit. In the event of such an occurrence advise your Jaguar Dealer/Authorised Repairer.**
- **The audio unit may be damaged if unsuitable items like credit cards or coins are pushed inside the CD aperture.**

Compact discs (CDs)

When handling CDs, do not touch the playing surface. CDs should be stored in their cases away from direct sunlight, heat and dust. Scratches, finger marks or dust on the surface of a disc can cause the optical pick-up to skip tracks. If the surface of a CD is dirty, use an appropriate CD cleaner.

Do not attempt to play discs that are damaged, warped, cracked or of incorrect size. They can seriously damage the unit's play-back mechanism.

Aerial operation

Caution: When using an automatic car wash ensure that the audio system is turned OFF so that the aerial is retracted. Ensure that enough time is given for the aerial to fully retract.

The aerial automatically rises when the audio system is switched ON. The aerial will lower when the audio system is switched OFF.

Note: *The aerial will always be raised regardless of being in AM/FM or CD mode to enable RDS information (where available) to be received.*

It is important to clean the aerial periodically to maintain smooth operation and good reception, see page 228.

Caution: Do not attempt to raise the aerial manually.

Audio

AUDIO UNIT OVERVIEW

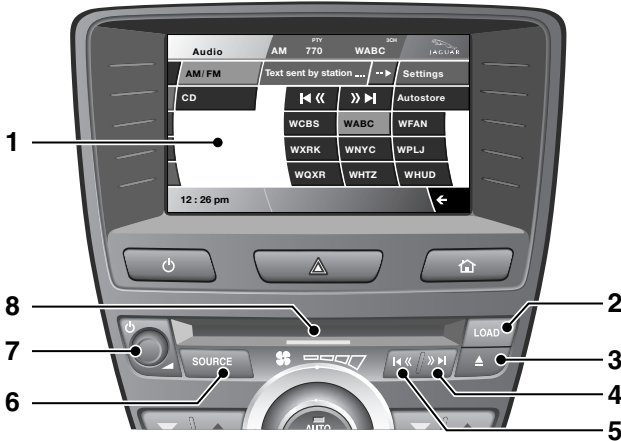

JAG0015NAS

The Audio Unit is located in the touch-screen console, and is controlled by **touch-screen buttons 1** and **hard buttons 2- 9)**.

- 1. Touch-screen:** See page 121.
- 2. Load:** Press to load CD, see page 195.
- 3. Eject:** Press to eject CD, see page 195.
- 4. Seek up:** Press arrow to seek radio frequency range up or to change CD track up.
- 5. Seek down:** Press arrow to seek radio frequency range down or to change CD track down.
- 6. Source:** Press to change radio band or to change the source media between radio or CD.
- 7. Audio system ON/OFF and volume:** Press the control knob to switch the system ON/OFF.

Volume control: Turn the control knob to increase or decrease volume. Any volume setting made whilst in audio, phone, navigation or voice activation mode, will be memorised for that system.

- 8. CD load and eject slot.**

Audio

USING THE AUDIO SYSTEM

The Audio system touch-screen structure flow charts are referenced at page 127.

To operate the audio system the ignition system must be ON (engine Start/Stop button pressed). When the engine is stopped, for the audio system to remain active, the START/STOP button must be pressed again without pressing the brake pedal.

The audio system can be turned ON in two ways:



Pressing the audio ON/OFF control knob on the touch-screen console, or

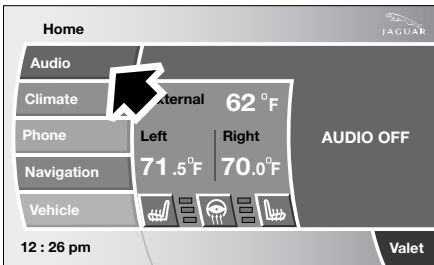

Pressing the **Audio** touch-screen button on the main **Home** touch-screen.

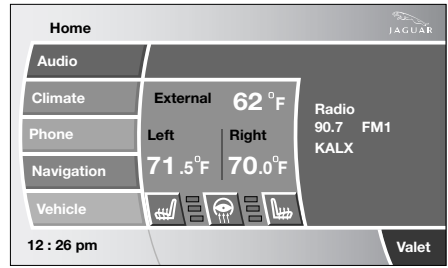

The touch-screen displays the current audio settings.

Radio broadcast system display panel (in AM/FM mode)

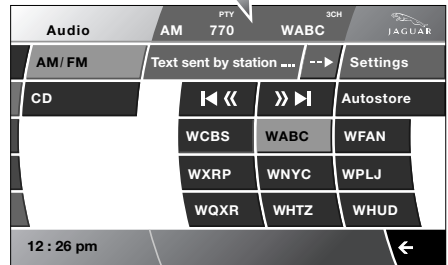

- PTY** Priority Programme Type selected.
- DPL II,** Surround mode - Dolby Pro
- 3CH** Logic II or 3CH.
- FM2** Frequency channel selected.
- 89.1** Frequency of selected station.
- WCBS** Radio station selected.

Audio

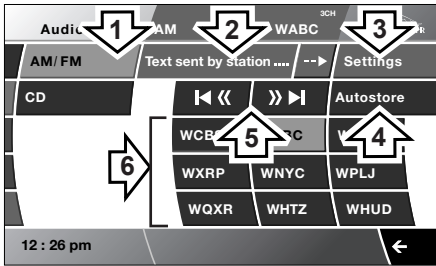

JAG0286NAS

1. **AM/FM band switching.**
2. **Radio text sent by radio station.**
3. **Settings.**
4. **Autostore.**
5. **Seek up and Seek down.**
6. **Preset memorised radio stations.**

RADIO SYSTEM OPERATION

AM/FM band switching

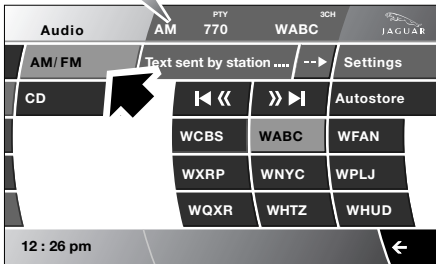

JAG0019NAS

Pressing **AM/FM** will cycle the radio through FM1, FM2 and AM. Band selection will be shown in the display panel. When a CD is being played, pressing the band switch will select radio operation.

Radio text sent by station

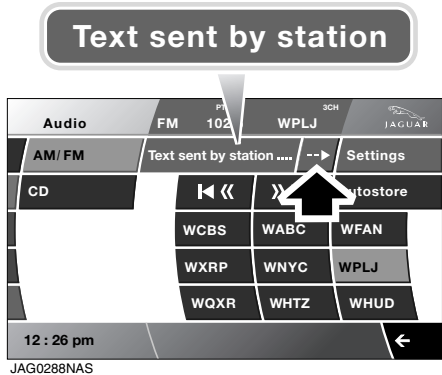

JAG0288NAS

Radio text messages sent out by the selected station.

To set the display to show radio text messages see **Settings - Options - FM text**.

A pop-up display screen is available, showing the whole of the message, by pressing the **continuation arrow**.

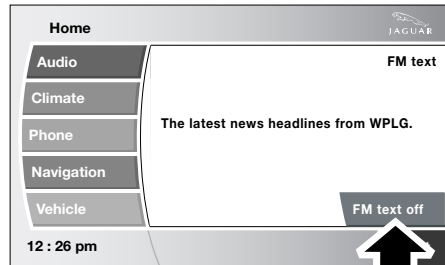

JAG0289NAS

The pop-up will time out after approximately 12 seconds, or can be cancelled by touching anywhere within the pop-up. Pressing the **FM text off** button will cancel the display for Radio text entirely.

Audio

Settings

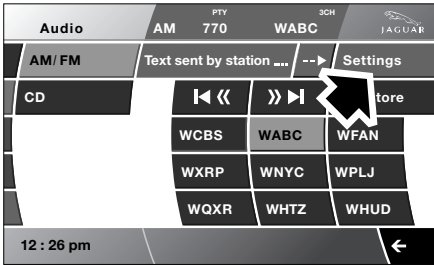

JAG0286NAS

When selected, displays the available audio system setting facilities.

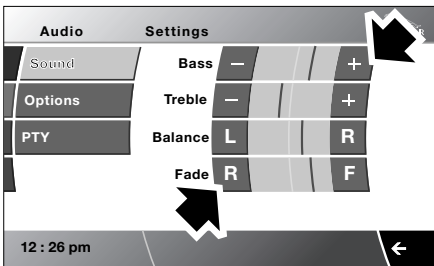

JAG0291NAS

Sound: **Bass**, **Treble** levels are increased or decreased by pressing the (+) or (-) buttons.

Balance, left to right, and **Fade**, rear to front, levels are optimised for a selected seating position by pressing the **L** or **R**, **R** or **F** buttons.

Options

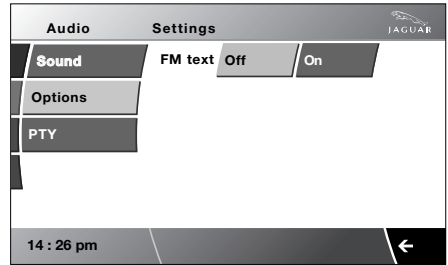

JAG0292NAS

Priority PTY interrupt skip: Interruptions for, **NEWS** or other selected priority **PTY**, can be skipped by pressing the **skip** button **1**. This will cancel the pop-up and the announcement. The radio will return to the previously selected audio source. Pressing anywhere within the pop-up **2** will cancel the pop-up but the announcement will continue.

Note:

- *Interrupt skip will not cancel activation of a priority **PTY** and it will remain ready for the next interrupt.*
- ***PTY** and priority **PTY** features are reliant upon the broadcast information from radio stations, and may be much better in some areas than others.*

FM text is selected either **ON** or **OFF**.

PTY (Programme type, where broadcast) This has two functions:

- to set a desired **priority programme type**
- to search for a programme type (**PTY Search**) and re-tune to it.

Audio

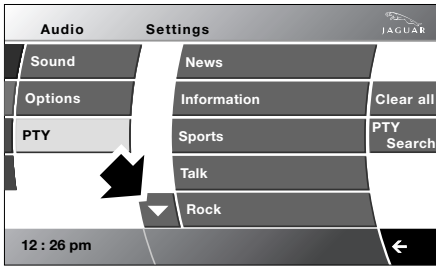

Use the scroll buttons to cycle through the available programme types (there are 30 types available), press the required menu buttons to select the desired programme types.

Priority programme type

Select the required priority programme, then select the previous screen button. The radio will now wait for RBDS information to indicate that a station has changed its programme type, e.g. to **NEWS**. The radio will now re-tune to the new station for the duration that it remains on that programme type.

If the current station is already on the selected priority programme type, then when this station is lost, the radio will attempt to find another with the correct programme type.

Note: *PTY interrupt feature is also active in the CD mode.*

PTY search

Once a desired programme type is selected press the **PTY search** button. If there is a station with the correct **PTY**, then the radio will re-tune to it. If not, the radio will indicate **NO PTY** and return to the current station.

While **PTY** is displayed, a search of the set **PTY** programmes can be carried out by pressing the **seek down** or **seek up** buttons.

Clear all will cancel ALL the selected priority settings, except for **PTY-Alarm**, and the **PTY** indicator will clear from the display,

PTY-Alarm (where broadcast)

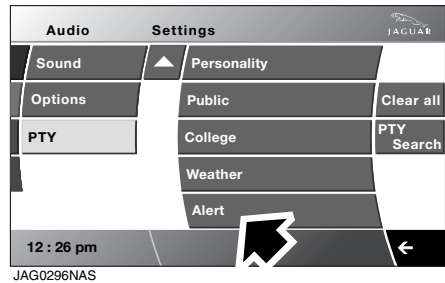

When using the radio with **RBDS** selected, a **PTY-Alert** service may be activated from the menu, to alert on any crises of major national importance. When such a broadcast is made, **ALERT** will appear in the audio display. The default setting is ON.

Audio

Seek tuning

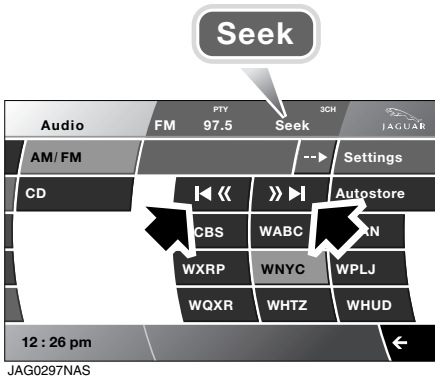

The **seek down** or **seek up** buttons on the touch-screen console and the touch-screen carry out the same function.

Short press: In AM or FM mode, pressing and releasing the **seek down** (left-hand) or **seek up** (right-hand) buttons 1 will activate the radio tuning through the frequency range, up or down, to the next available station.

The touch-screen will display **Seek** on the upper display until a station has been found, and will then display the station name, where available.

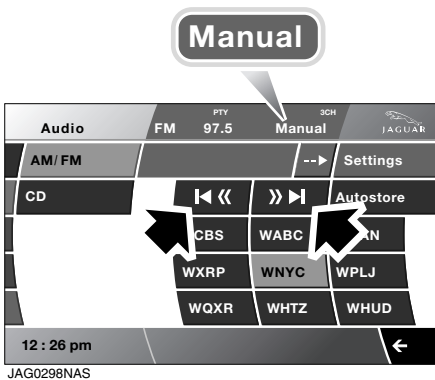

Long press: In AM or FM mode, for as long as the button is being pressed the frequencies will be scanned either up or down.

The touch-screen will display **manual** on the upper display for a short time. While this is displayed, a short press of the buttons will also allow the frequencies to be scanned.

Autostore

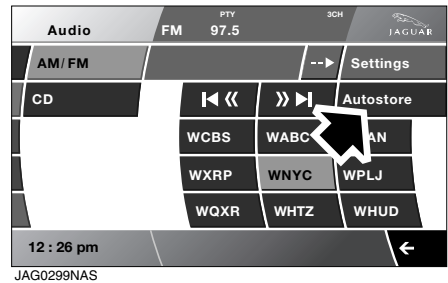

Autostore: The automatic memory function programmes up to nine strong stations on a selected waveband to presets 1 to 9.

To activate this function, press and hold **Autostore** button for at least two seconds.

The radio will be briefly muted while it searches the selected waveband (AM, FM) for up to nine strong stations.

When programming is completed the radio will default to preset number 1, and audio volume will be restored.

If stations cannot be located for all the preset positions, those that are found will be allocated positions commencing with number 1, leaving the remainder not programmed. The display will show ---- and be greyed out if unprogrammed preset are selected.

Audio

When programmes have been set: A short press of **Autostore** will allow the user to switch between the automatically stored stations and the manually stored stations.

Preset memorised radio stations (1 - 9)



WARNING:

In the interests of road safety, do not attempt to preset a station while driving.

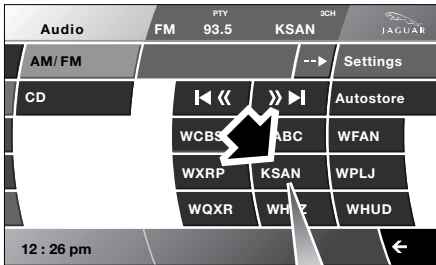

JAG0300NAS

On each waveband (AM, FM1, FM2), nine stations can be memorised using the touch-screen keypad buttons. After tuning to a station, press and hold the selected button until the station has been stored. A station can be recalled from the preset memory by pressing and immediately releasing the button.

A long press of the steering wheel preset selector button will cycle through the preset stations.

Automatic volume control (AVC)

This maintains radio volume at a level sufficient to overcome road noise as vehicle speed increases or decreases.

To activate the AVC:

- From the main **Home** touch-screen menu, select **Vehicle**.
- Select **Syst. settings**.
- Select **Vol. presets**.

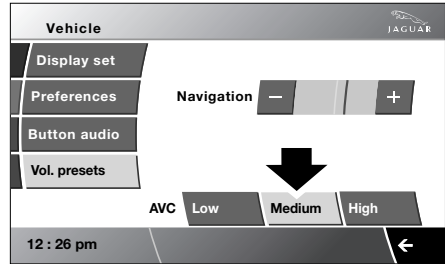

JAG0301NAS

- Select either Low, Medium or High for the **AVC**.

Jaguar Premium Surround Sound

This audio system has the facility of Digital Signal Processing (DSP) which optimises the sound for specific seating positions.

It also allows the user to select stereo, 3-channel stereo or Dolby Pro Logic II Surround Sound. It is recommended that Dolby Pro Logic II Surround Sound is used in CD mode and strong FM transmissions.

Note:

- *When various setting are altered in DSP, the sound will briefly fade while the settings are changing and will return to normal when the change has been completed.*
- *Convertible only: The sound will automatically change for when the convertible top is up or down.*

Audio

Settings

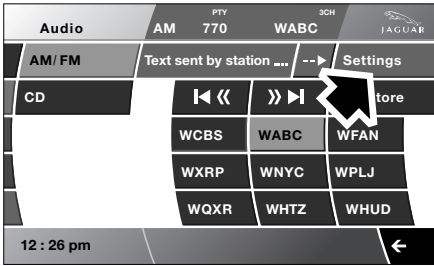

JAG0286NAS

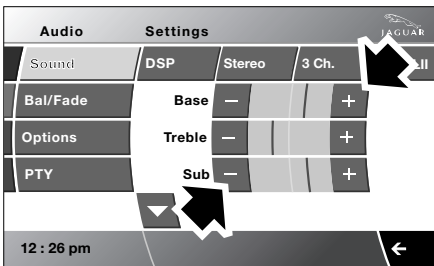

JAG0303NAS

When selected, defaults to **Sound** and displays the available premium audio system setting facilities.

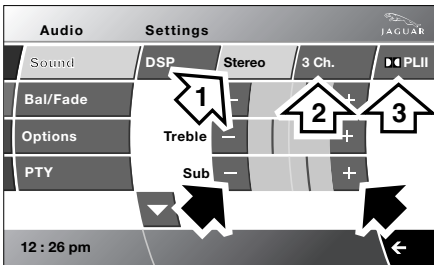

JAG0306NAS

- **Stereo, 1**
- **3 Ch, 2**
- **Dolby Pro Logic II Surround Sound, 3.**

These levels are altered by selecting the appropriate buttons.

Bass, Treble, Sub levels are increased or decreased by pressing the (+) or (-) buttons for the system facilities.

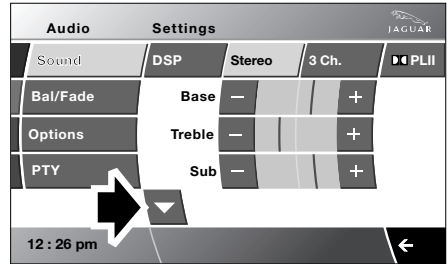

JAG0307NAS

To select further settings, use the scroll down button to access the next screen display.

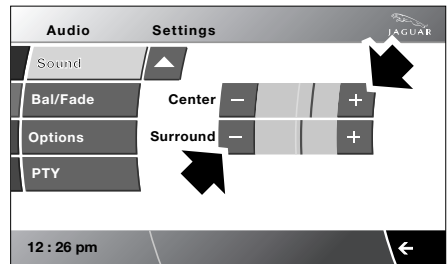

JAG0308NAS

Select either **Centre** or **Surround**.

Note: The number of available settings will depend on whether **Stereo, 3Ch** or **Dolby Pro Logic II Surround Sound** is selected.

Audio

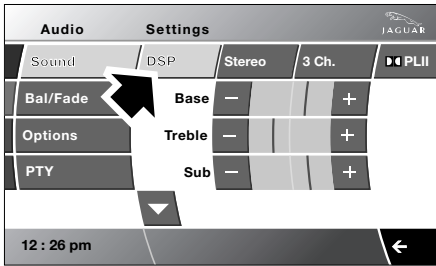

JAG0304NAS

DSP (Digital Signal Processing): To optimise the sound for specific seating positions select **DSP** and then select the required seating position.

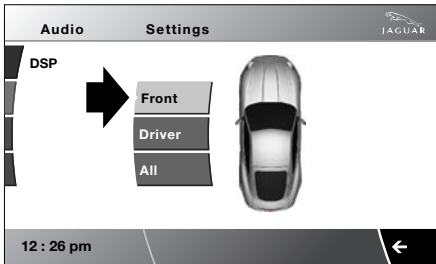

JAG0305NAS

Either **Front**, **Driver** or **All** may be selected.

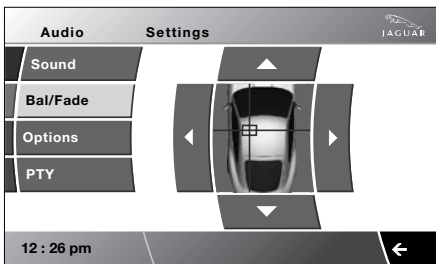

JAG0309NAS

Bal/Fade: The sound can be optimised by using the scrolling buttons to alter the Balance (left to right) and Fade (front to rear).

Options and **PTY** functions are the same as for the Jaguar Sound System, refer to **Settings** on page 187.

RADIO BROADCAST DATA SYSTEM (RBDS)

Your radio is equipped with RBDS, which enables the audio unit to receive additional information with normal radio signals.

When tuned to certain stations on the FM waveband the radio decodes signals transmitted to provide the following functions (dependent upon the service available from the broadcasters).

Note: Not all FM radio stations broadcast RBDS. If a non-RBDS station is received, RBDS features will not be available.

- **RBDS station name display:**
When RBDS is selected the station name is displayed.
- **RDS Priority programme type auto re-tuning (where broadcast):**
Can be selected to interrupt and switch to the selected programme type e.g. **News**, for its duration or can be used to search for specific **PTY** stations.

If the RBDS function does not respond correctly, see the trouble-shooting guide on the next page.

Audio

RBDS trouble-shooting guide

Incorrect response from RBDS	Reason and rectification
Radio does not display programme name.	RBDS name is not available from the broadcast.
Station name is lost and displays frequency only.	Radio has lost reception of the RBDS data due to vehicle moving out of transmitter range, loss of signal in a tunnel, under a garage forecourt canopy, or similar screening. If the latter is the case, when the vehicle is clear of the screening, the station name will return after a short delay.

Audio

COMPACT DISC (CD) SYSTEM OPERATION

Caution:

- Copyright laws vary in different countries; check the laws in your country if you want to record from copyright source material.
- Due to technical incompatibility, recordable (CD-R) discs and re-writable (CD-RW) discs may not function correctly.
- These CD units will play compact discs that conform to the international Red Book standard audio specification. Copy protected CDs from some manufacturers do not conform to this standard and playback cannot be guaranteed.
- Dual format, dual sided discs (DVD Plus, CD-DVD format), now being adopted by the music industry, are thicker than normal CDs and consequently playback cannot be guaranteed in Jaguar audio units, and jamming could occur. Warranty claims, where this type of disc is found to be inside an audio unit returned for repair, will not be accepted.
- Irregular shaped CDs and CDs with a scratch protection film or self adhesive labels attached should not be used.

Note: Some privately recorded CD-R discs may not have been acceptably formatted to be able to be played on this CD player.

An in-dash 6 compact disc (CD) player is installed in the touch-screen console, see page 184, and it will accommodate up to six discs. It will play Compact Disc Digital Audio (CDDA) discs (normal discs), MP3 and WMA files.

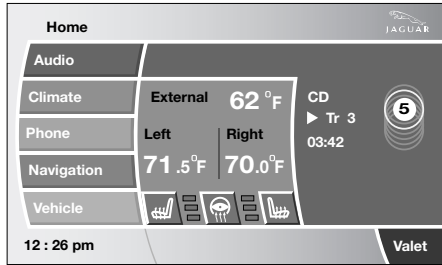

The main **Home** screen display will indicate which CD loaded and ready for playing. If no CDs have been loaded, the touch-screen indicates the unloaded state by displaying the six ghosted discs.

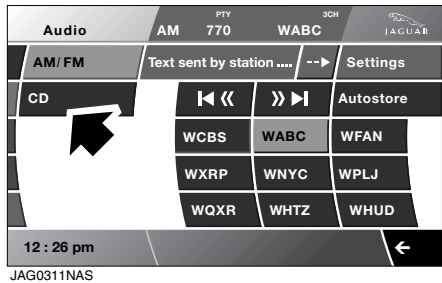

To access the CD player touch-screen:

- From the main **Home** touch-screen menu, select **Audio**.
- Select **CD**.

Audio

To load the CD player

Single CD - player empty:

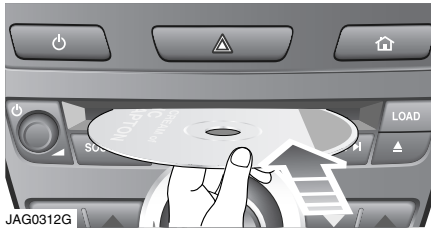

Load a CD into the loading slot. A CD loading message is displayed on the touch-screen.

Single CD - player partially loaded:

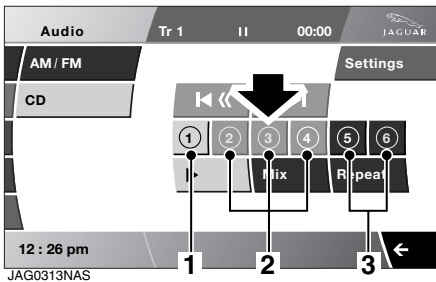

From the CD player touch-screen, select an empty slot **2**, **1** indicates the current playing CD, **3** indicates loaded slots. A message indicates to insert the CD into the empty slot. Load a CD into the slot.

More than one CD:

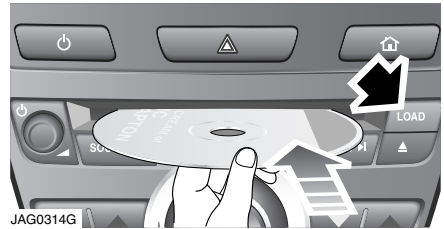

Press the **LOAD** button and insert each CD into an CD slot as requested by the displayed message. A pop-up message on the screen will indicate which slot is being selected until the unit is fully loaded.

When the CD player has been loaded, CD operation is via the CD touch-screen.

To unload the CD player



Press the eject button. A short press will eject a single CD, a long press will eject each loaded CD in turn.

Audio

CD Touch-screen display and operation

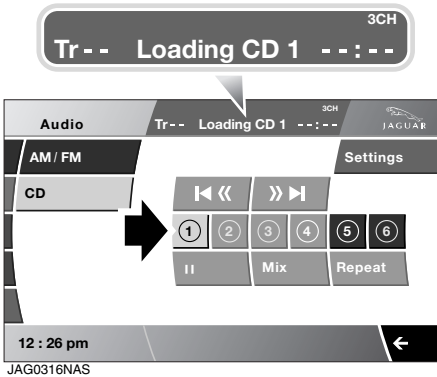

DPLII Surround mode - Dolby Pro
or Logic II selected or 3-channel.
3CH

When a CD has been selected, the upper display indicates which disc is being loaded and will commence playing when loading has been completed.

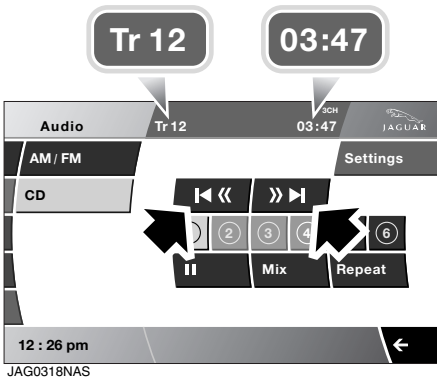

TR12 - Track number display of the track being played.

03:47 - Track elapsed time play.

Seek down and **seek up** buttons:

- **Short press:** Seeks down to previous track or up to next track.
- **Long press:** Press the **seek down** to play rapidly back through one or more tracks (review). Press the **seek up** to play rapidly forward through one or more tracks (cue). Normal playback will resume when either button is released.

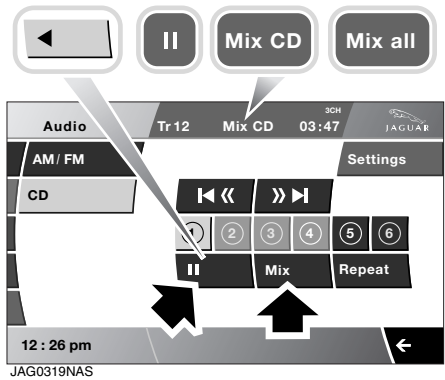

II - Pause button; Will pause the playing track until pressed again. To resume the CD, press again.

Mix CD: Short press: The track order of play from the current CD is randomly selected by the CD player, (on MP3 CDs a short press will mix the tracks from the current folder).

Mix all: Long press: The CD order of play is randomly selected, by the CD player, from all the loaded CDs, (on MP3 CDs a long press will mix the tracks from all the folders of the current MP3 disc).

Note: If the volume is turned down to zero, the CD is automatically paused. Play is resumed when the volume is increased.

Audio

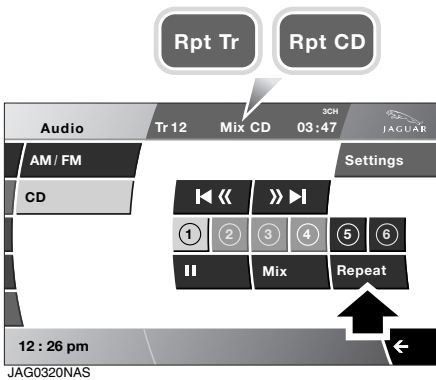

Repeat:

- **Short press: Rpt Tr:** Will repeat the playing of the track continuously until repeat is cancelled by pressing again.
- **Long press: Rpt CD:** Will repeat the playing of the whole CD continuously until repeat is cancelled by pressing again.

Settings

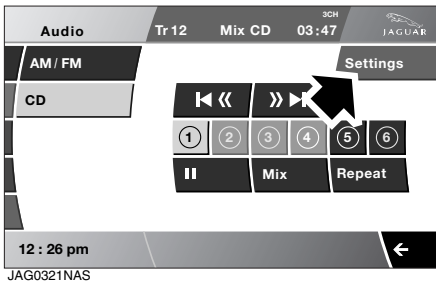

When selected, displays the available CD system setting facilities similar to the audio system, see pages 187 and 191.

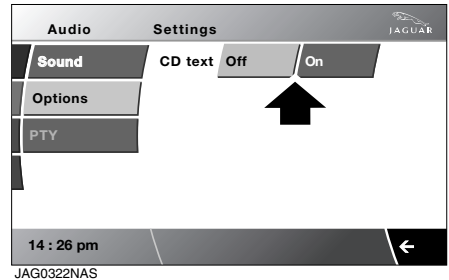

Options: CD text can be selected in the CD mode.

The **CD text** display is similar to the Radio text, but displays text that has been recorded onto the CD (not all CDs have CD text).

COMPACT DISC - RECORDABLE (CD-R)

Some pre-recorded and personally recorded discs, can contain additional information on the disc, e.g. CD titles, track titles and the artists name (ID 3 Tags).

Additional buttons allow you to select folders and tracks and display various items of information about the recordings. Typically, MP3 discs have the potential to hold a great deal more music than a conventional CD because each track can be compressed to a higher degree during recording.

If you record your own music, each session must be properly closed, but the whole disc does not have to be finalised.

Note:

- *A mixture of CDs and MP3 discs can be loaded into the CD player together.*

Audio

- The CD player is not guaranteed to play every disc available because of variations in the quality of discs.

Playing MP3 discs

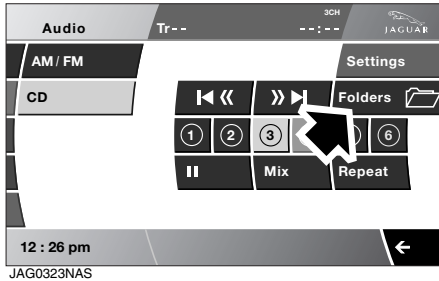

If the MP3 disc has been recorded with the music files contained within folders, additional information is available by selecting **Folders**.

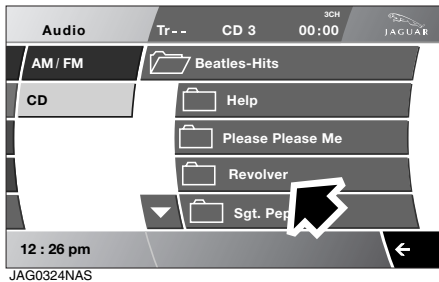

The titles of any tracks and folders recorded on the CD will be displayed in alphabetical order as the disc may be recorded in another order.

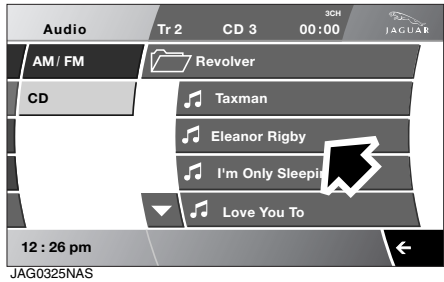

Select the folder to access the tracks contained within the folder.

MP3 folder and track format

A CD-R or CD-RW can have MP3 folders and tracks recorded in many different ways, with many layers of folders and with tracks distributed throughout the folder structure.

To minimise the loading on the system, a rigid folder structure is recommended.

Note:

- Any CD containing a mixture of MP3 and CDDA tracks will be treated as a CD (any MP3 tracks will be ignored).
- The CD player may take a long time (one minute or more) to load an MP3 disc owing to the number of tracks on it.

Satellite Radio

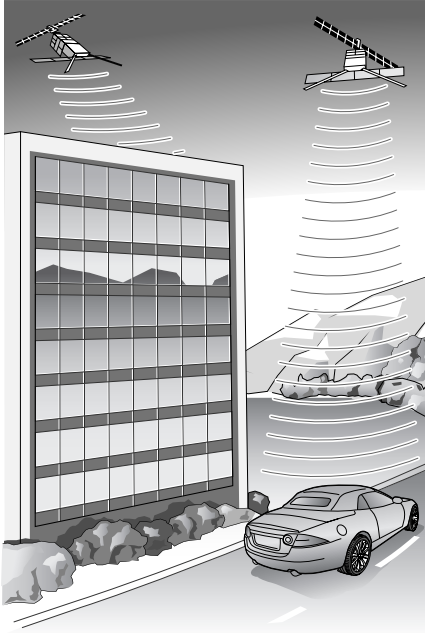

JOL4489

SATELLITE DIGITAL AUDIO RADIO SERVICE (SDARS)

Signals from a satellite broadcast radio service are encoded and a subscription to the broadcast operator (SIRIUS) is required to receive them.

The following features are inhibited when driving:

- Parental lock.
- Channel skip.
- Edit favourites - song seek list.

As a digital signal is used, satellite radio is able to provide output of radio broadcasts with the sound quality and clarity of CD playback.

RECEIVING SATELLITE RADIO BROADCASTS

To access satellite radio from the vehicle **Home** screen:

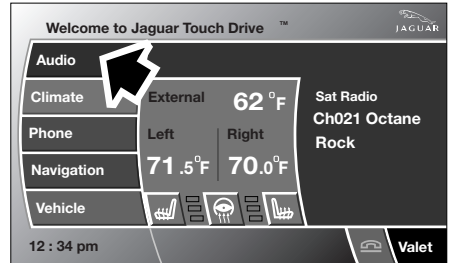

JOL4458

- Select **Audio** on the touch-screen.

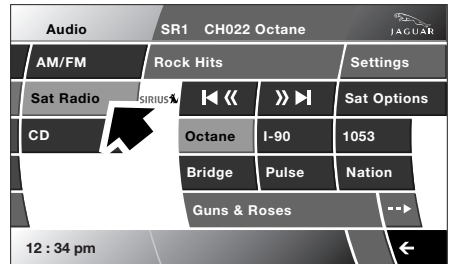

JOL4673

- Select **Sat Radio**.

If you are not currently subscribed to SIRIUS, **No Subscription** will be displayed below **Sat Radio** followed by a subscription screen, see page 209.

Satellite Radio

Satellite radio display panel

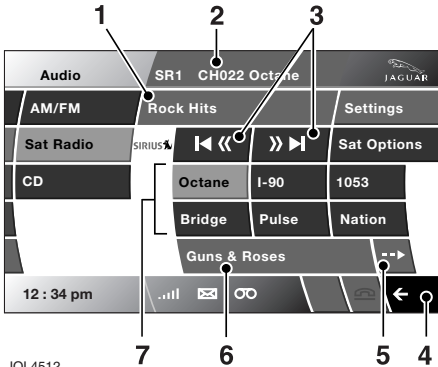

JOL4512

1. Category of music which is currently selected.
2. Channel which is currently selected.
3. **Seek up** and **seek down** buttons.
4. Back - to previous screen or setting.
5. Programme description text (PDT) description, which provides details (where available) of the artist's name, song title and the composer and subscription information.
6. PDT text display area - artist currently playing.
7. Six preset memorised radio channels. Press to select the required channel e.g. Octane preset is selected in the above example.

Note: If manual tuning is used and a channel is selected that is an existing preset, the preset will highlight. If the same channel is stored in more than one preset (on different screens for example)

Preset memorised radio channels

Three screens are available, listed as SR1, SR2 and SR3, each displayed on the top line of the screen. Each screen can display up to six preset channels, giving a total of 18 possible preset channels.

Selecting **Sat Radio** repeatedly, cycles through the three screens.

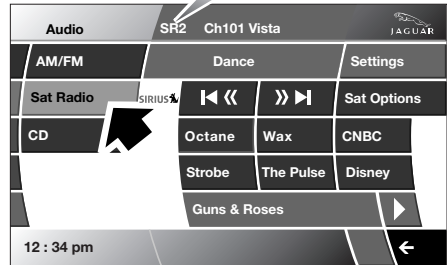

JOL4461

Preset memorised channel - setting

To save a channel as a preset, tune into the channel that is to be stored, then press and hold the desired preset button for approximately two seconds. Audio output is muted while the channel is being stored and returns once the operation is complete.

To change a preset, select the desired channel either via **Category lists**, see page 204 or manually, **Direct channel entry**, see page 205. Then press and hold the desired preset until the new channel is stored.

and manual tuning is performed, the first preset will highlight.

If required, repeat the procedure to store up to 17 other satellite channels.

Satellite Radio

Recalling a preset channel

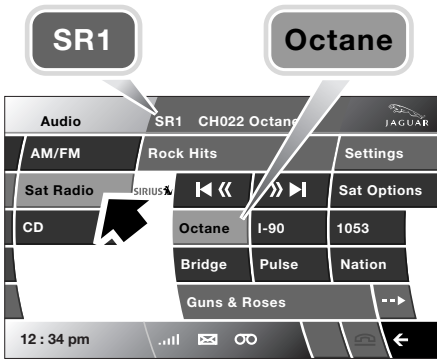

JOL4460

Select the appropriate source where the desired channel is located (SR1, SR2 or SR3) by pressing **Sat Radio** to cycle through the list.

Select the desired preset button, e.g. Octane. Audio output will switch to the satellite channel stored on the selected preset.

Seek Up and Seek Down

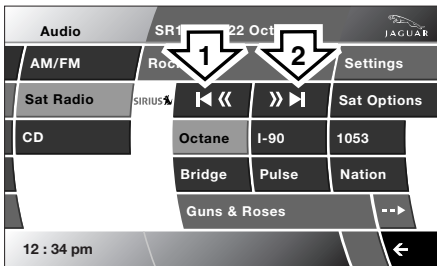

JOL4513

Short press: Either the seek down button (1) or seek up button (2) to step to the next numerical channel.

The channel which is displayed on release of either button will be the channel that satellite radio will tune to.

SONG SEEK

Song Seek can store up to 10 song titles along with the artist's name etc., if it is transmitted with the PDT (Programme Descriptive Text) information.

If, while listening to any satellite channel, one of the stored Song Seek Favourites is playing on any other satellite channel, the user will be alerted visually. The user can choose to tune to that channel.

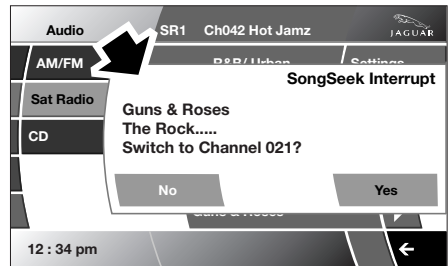

JOL4493

The display indicates that the user is currently listening to **Ch042** (Channel 42 Hot Jamz on SR1).

The Song Seek pop-up (Song Seek Interrupt) is giving the user the choice to listen instead, to a Favourites (Guns & Roses) which is currently playing on Channel 021.

Satellite Radio

Activating song seek

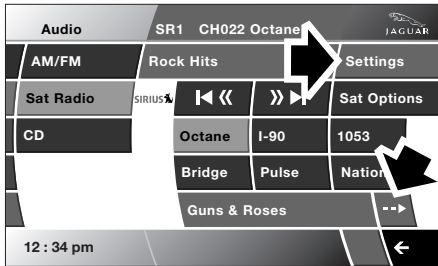

To activate Song Seek, select **Settings** and then select **Song Seek**.

When the feature is active, pressing the **PDT** button on the Settings display screen, will present the user with the Satellite Information display pop-up where the current favourite songs can be viewed and edited.

When the feature is not active, the user cannot add to or edit the favourite songs list. However, the **PDT** information can still be seen by selecting the **PDT** button.

Editing song seek favourites list

Note: *Editing of the favourites list cannot be carried out while the vehicle is in motion.*

To edit the list of songs in Song Seek, select **Edit Favourites** on the SAT Information pop-up.

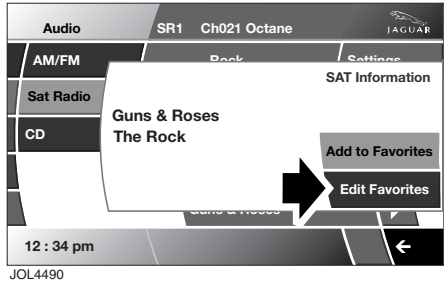

If Song Seek is not active, then both **Add to Favourites** and **Edit Favourites** will be inoperative.

If **Edit Favourites** is selected, then the following screen will be displayed.

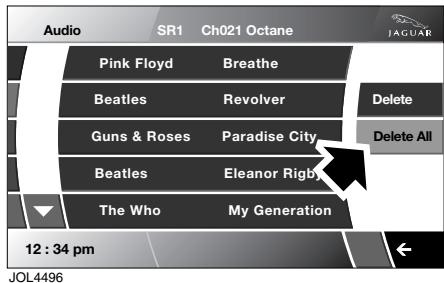

Delete All is highlighted and if selected, all songs in the Song Seek favourites list will be deleted.

Should only one song at a time be required to be deleted, select the particular song on the list.

Satellite Radio



JOL4495

Select **Delete** to delete that song only. Repeat the procedure for each song to be deleted.

In all cases the user will be asked to confirm that the song or songs should be deleted.

Adding a song to the favourites list

To add a song to the Song Seek favourites list, the following is necessary:

- The song should be currently playing.
- The user must select the **PDT** button; a right-hand facing arrow situated at the lower right hand side of the screens.

The following screen will provide the details of the song and give the user the choice to add it to the favourites list.

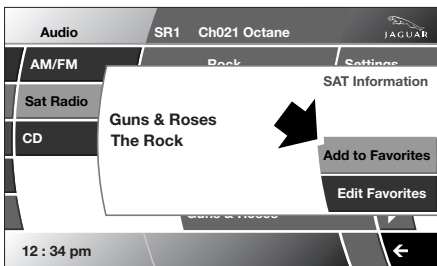

JOL4492

If the user adds the song to the favourites list, confirmation is as follows:

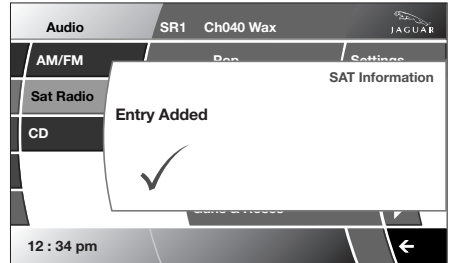

JOL4491

Favourites list is full

If the favourites list is full, the SAT Information pop-up will indicate **Entry List is full. Delete Entry?**

One or more songs must be deleted before another song can be entered.

All songs may be deleted if desired.

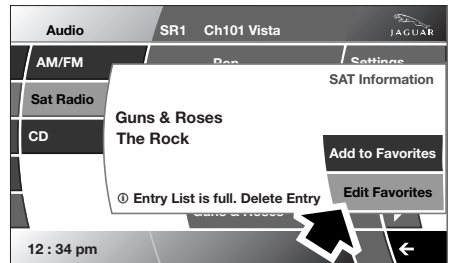

JOL4494

To be able to put the Guns & Roses example into the song seek favourites list, first **Edit Favourites** in order to make space.

Satellite Radio

SAT OPTIONS MENU

The Sat Options button on the satellite radio screen provides four other menu features plus a SAT information screen.

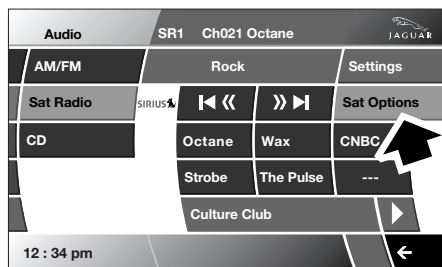

JOL4466

Select **Sat Options** to view the available options.

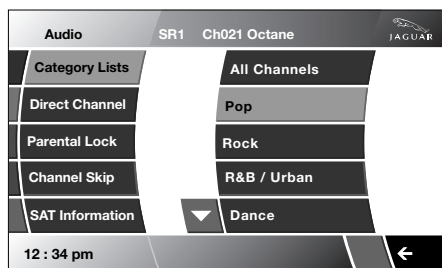

JOL4467

The options are:

- Category Lists.
- Direct Channel.
- Parental Lock.
- Channel Skip.
- SAT Information.

Category lists

The above screen shows that **Category Lists** has already been selected and that the **Pop** category has also been selected.

The following screen shows some of the various channels that play music within the **Pop** category.

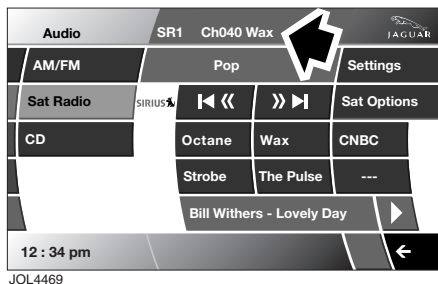

JOL4469

Once a channel within the Pop Category (or any other category) has been selected, the radio will re-tune to that channel and the display will return to the Sat Radio Home screen, but with the new channel information displayed.

The new channel is **Ch040 Wax**, whereas the previous channel was **Ch021 Octane**.

Browse PDT

The Browse feature allows the user to scan all available PDT (Programme Descriptive Text) within a given category without changing the current satellite channel.

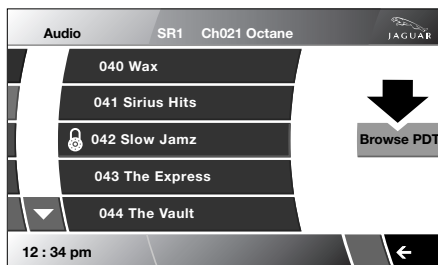

JOL4468

Satellite Radio

The Browse feature will update the PDT information as programme information changes within the SIRIUS broadcast.



JOL4470

This view can be maintained while listening to the audio on the current satellite channel. The user can scroll across all available channels using the up and down arrows to view broadcasted PDT information. At any time a new channel can be selected and the screen will return to the normal satellite view.

Direct channel entry

This option allows the user to input the channel number directly.

Select **Sat Options** on the satellite radio Home screen.

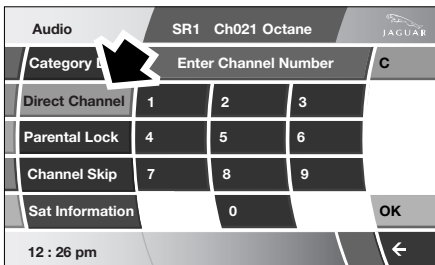

JOL4473

Select **Direct Channel** on the **Sat Options** screen, and a numerical keypad will be displayed. The user is asked to enter a channel number.

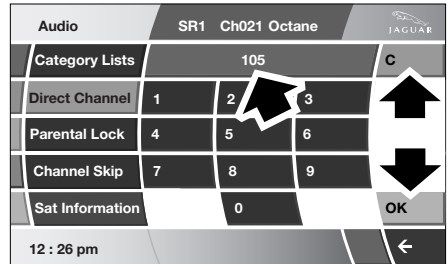

JOL4474

Channel number 105 has been entered.

A short press on the **C** (Clear) button will delete one digit at a time.

Select **OK** when the desired channel number has been entered correctly.

If an invalid channel number has been entered, this will be displayed on the screen.

If a valid channel has been entered, then the following screen (Sat Radio Home screen) will be displayed, but with the new channel information.

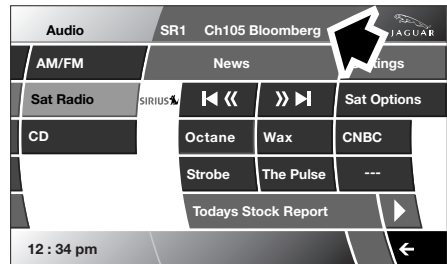

JOL4475

Parental lock

This option allows the user to lock any given channel or channels to prevent them from being accessed.

The locked channels will be skipped when navigating through the channels using the **seek up** or **seek down** buttons.

Satellite Radio

To set-up, select **Sat Options** on the satellite radio screen.

Note: Parental Lock cannot be performed while the vehicle is in motion.

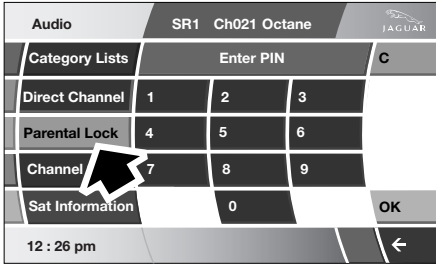

JOL4476

Select **Parental Lock** on the **Sat Options** screen, and a numerical keypad will be displayed. Enter a PIN number.

Number entry is identical to that for Direct Channel Selection, except that there must be four digits e.g. 125 must be entered as 0125 etc.

If the correct PIN is entered the following screen is displayed which shows the different Categories and **All Channels**.

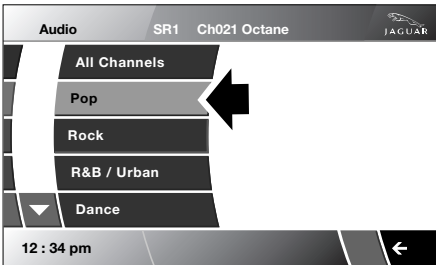

JOL4477

Pop category has been selected.

After selecting **Pop**, the following screen will be displayed:

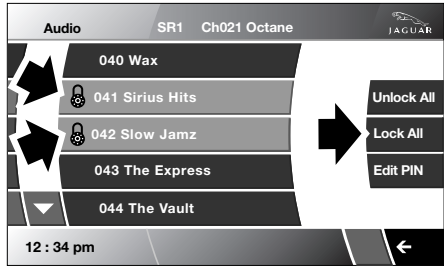

JOL4478

Two channels are shown with the Lock symbol.

There are three keys that the user can use to lock or unlock channels.

The user can lock or unlock an individual channel or lock them all within a Category. To lock an individual channel, just select the desired channel and select **Lock** or **Lock All** depending on what is displayed. The unlock procedure is the same.

Edit Personal Identification Number (PIN)

To edit the parental lock PIN, the user must first enter the existing PIN.

If the system confirms that the entered PIN is the correct one it will respond with **PIN Verified - Enter New PIN**.

Enter the desired PIN (four digits).

This new PIN will then be stored and over-write the previous one. A SAT Information pop-up will indicate **New PIN Accepted**.

Viewing a locked channel

When a locked channel is selected by Channel Navigation, Direct Channel Entry or Search by Category, it will not play and will give the message **Channel Locked Enter PIN**.

Satellite Radio

Enter the PIN via the keypad which will subsequently be displayed.

If the correct PIN is entered, the channel will play. However, the channel will play only for the current driving cycle and will again be locked the next time that the vehicle is started and used.

If the PIN that is entered is incorrect, the message **Entry Invalid - Please try again** will be displayed.

Lost PIN information

If the user loses or forgets the PIN, access may still be gained and a new PIN entered, as follows.

Select **Sat Options** on the satellite radio screen, to display the Options screen:

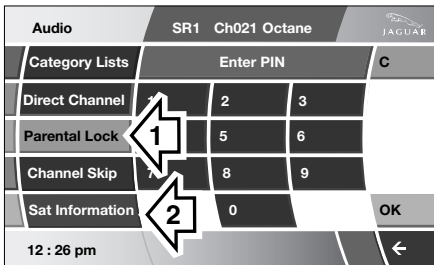

- Select **Parental Lock 1** on the **Sat Options** screen, and hold for 10 seconds - then release.
- Select **SAT Information 2** and hold for 10 seconds - then release.
- After a time-out period, the system will display **User PIN Has Been Reset**.

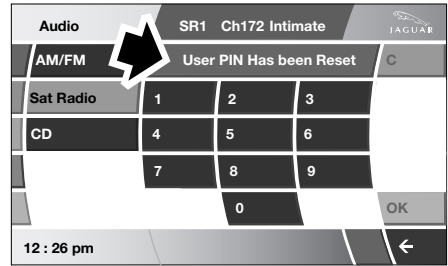

The PIN will have been reset to the system default of 1111.

Go to **Edit PIN** and enter a new number.

Channel Skip

Channel Skip can be used to hide channels from being selected when using the **seek up** and **seek down** buttons - the channels are actually skipped, not hidden.

Select **Sat Options** on the satellite radio screen, to display the **Options** screen:

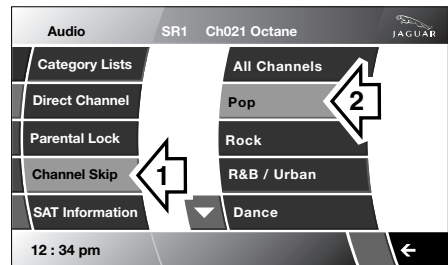

Select **Channel Skip 1** on the **Sat Options** screen and the Category List will be displayed.

Select the Category in which to view the channels e.g. **Pop 2**.

When **Pop** has been selected the channels within that category will be displayed.

Satellite Radio

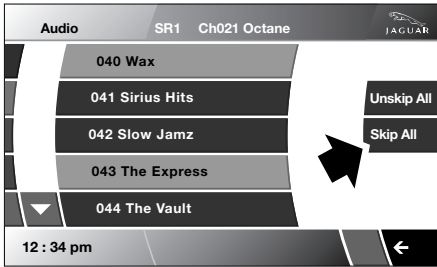

JOL4480

Individual channels within a category can be Skipped by selecting a channel and pressing **Skip**.

All channels within a category can be Skipped by pressing **Skip All** or unskipped by pressing **Unskip All**.

Hidden (skipped) channels are accessible by Direct Channel Entry.

Note: If same channel is locked and skipped, then when the channel is unlocked it will become unskipped.

SAT Information

The SAT Information screen contains the SIRIUS contact telephone number and the satellite radio Identification Number.

Select **Sat Options** on the satellite radio screen, to display the **Options** screen.

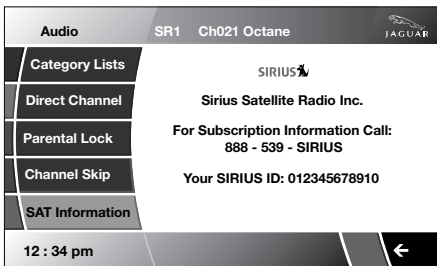

JOL4481

Select **SAT Information** on the **Sat Options** screen. This information is displayed automatically when the system is asking the user to subscribe to SIRIUS.

SUBSCRIPTION TO SIRIUS

When **Sat Radio** has been selected, but a subscription to the provider has not been made, a message will appear, showing the telephone number of the provider.

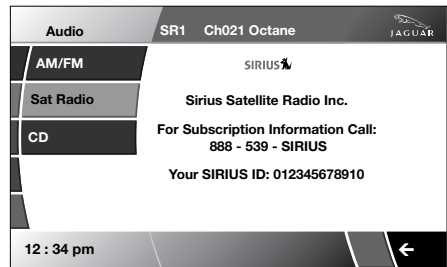

JOL4464

Also shown is the **SIRIUS ID** that identifies the receiver unit and is linked to the VIN of the vehicle.

To subscribe, call the number indicated and quote the **SIRIUS ID**, this would normally be done by your Jaguar Dealer.

If SIRIUS has not yet been subscribed to, the system will tune to the preview channel - currently number 184. This channel is accessible for a limited period only, for approximately 90 days after purchase of the vehicle.

The ignition system must be ON and the vehicle must be outdoors in plain view of the sky whilst authorisation takes place. This authorisation/activation can take up to 15 minutes.

Satellite Radio

Unsubscribed radio channels

If a channel is selected for which there is no valid subscription, **Unsubscribed Channel** is displayed.

Either subscribe to this selected channel or select an alternative channel that has already been subscribed to.

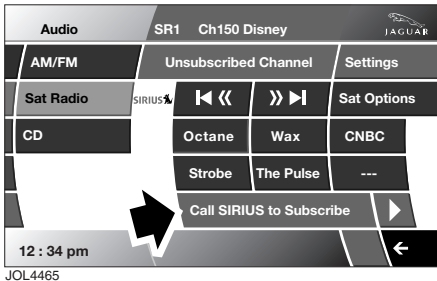

At the bottom of the screen **Call SIRIUS to Subscribe** is displayed. Select the right arrow button to display the Subscription Details Pop-up screen.

Automatic updates of channels

Occasionally the system will be updated automatically by SIRIUS.

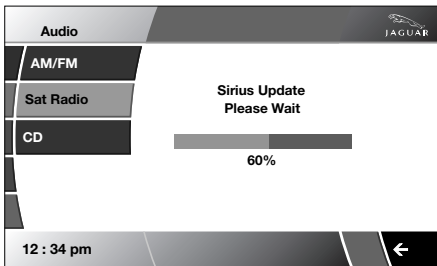

Whilst updating, the audio will be muted. When updating has been completed the update screen details cancel.

After the automatic update procedure, the following should be noted:

1. All locked channels will be unlocked.
2. All skipped channels will be unskipped.

Signal acquiring

If the satellite signal is lost, or not found, **Acquiring** will be shown on the display.

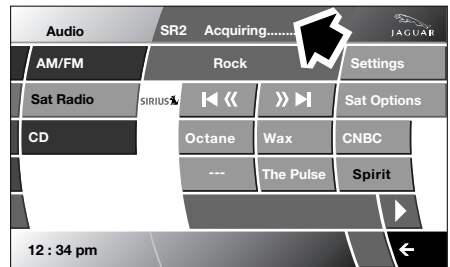

If the signal is not regained within a few seconds, all of the relevant soft buttons will be inhibited. The dotted line after **Acquiring** will flash until the channel is regained.

When the signal has been regained, the selected channel will again play.

Note: This is NOT the same as No Subscription. The system is only informing the driver that it cannot find the signal, perhaps because of very tall buildings or the vehicle is in a long tunnel.

Telephone

WHAT IS BLUETOOTH?



WARNING:

- **Using any hand-held appliance while driving can be dangerous and is illegal in certain countries.**
- **Always stop the vehicle before making a call and ensure that the telephone is switched off while you are driving.**

Bluetooth is an international standard that allows electronic devices to communicate with each other using a short-range radio link. Bluetooth eliminates the need for wires or cables. Typically, devices can communicate at a range of up to 10 metres (33 feet).

The Bluetooth in-car telephone system allows certain cell phones to be used hands free in your vehicle. There is no need to connect the cell phone to a cradle or cable.

Bluetooth is a registered trademark of Bluetooth SIG, Inc.

SYSTEM OVERVIEW

Note:

- *The vehicle ignition system must be ON and the touch-screen system must be active in order to use the phone.*



If your cellphone battery charge becomes low it may switch off its Bluetooth link to the vehicle. This is normal for cell telephones to help preserve remaining battery charge. In this event, the vehicle touch-screen will display a Phone connection message.



Whilst in a phone call, the phone uses its own antenna to communicate to the cellar network and therefore the phone reception is controlled by the cell telephone itself.

The vehicle's Bluetooth telephone system can be used with an appropriate, Bluetooth-equipped cell phone.

Please refer to your Jaguar Dealer for a list of compatible phones.

The cell phone must be paired and docked with the vehicle system before use, see **SETTING UP YOUR PHONE** on page -211. Once paired and docked, the phone can be operated via the steering wheel switches, the cell phone or the touch-screen.

The cell phone doesn't need to be physically connected to the vehicle, it can be left in a jacket pocket, for instance. Calls are routed through the vehicle's audio speakers, and a dedicated microphone is fitted behind the A post trim on the drivers side.

You can use the system to answer or reject incoming calls, make outgoing calls or alter the call volume. The system does not support SMS text messaging.

Call volume

The volume of the telephone call can be adjusted for hands-free operation. To adjust the volume, operate the audio system's volume control during a phone call, see page 184.

If the audio system is in use when the phone becomes active, the audio system source is suppressed for the duration of the call.

Telephone

The Jaguar telephone system is designed to function with a variety of Bluetooth equipped cell phones. The audio and echo characteristics vary between models of cell phones, as a result, it may take a few seconds for the vehicle system to adapt to provide optimal audio performance.

In order to achieve the best possible audio performance, it may be necessary to reduce the system volume slightly when using certain cell phones.

SETTING UP YOUR PHONE

Telephone pairing and docking

Before use, your cell phone must be connected or paired and docked with the vehicle's Bluetooth system.

Note: *Pairing is the process that uses a secure communication channel to allow two Bluetooth devices to recognise each other e.g. the vehicle and the cell phone.*

Docking means that a phone has been paired, recognised, and now requires to be connected to the vehicle

Follow these steps to pair/dock your phone:

1. Switch on your cell phone's Bluetooth connection, using the phone's menu. Make sure that your cell phone is in Bluetooth **discoverable** mode, sometimes referred to as **find me** mode. (See your phone's manual for more information.)
2. Switch the vehicle's ignition system ON, ensure that the touch-screen system is active.

3. From the home menu screen select **Phone**.

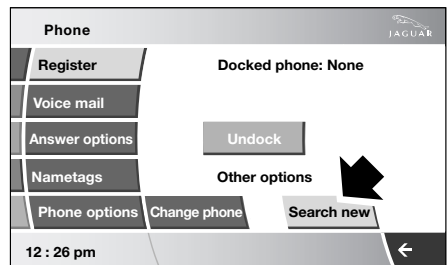
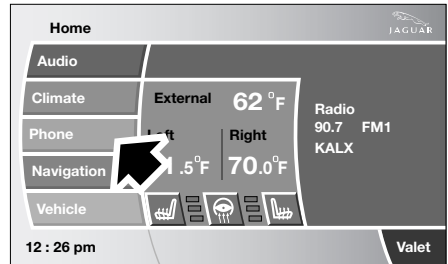

JAG0326NAS

4. If this is the first time that a phone has been paired to the vehicle select **Search new**. The system will search for all Bluetooth phones that are in range. If a phone is already docked it will be automatically undocked when a search is initiated.

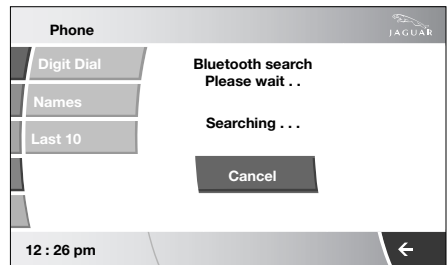

JAG0326NAS

Telephone

Note: Ensure that the **Timeout to home screen** is turned **Off** before starting a search sequence, see page 126.

5. If a phone has previously been paired to the vehicle select **Phone** then **Settings**.

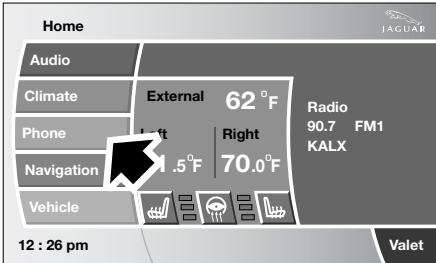

JAG0327NAS

6. Select your phone from displayed list.
7. Once you have selected your phone a pop-up window appears.

To pair and dock phone enter XXXX on the handset, XXXX being a random four digit code displayed on the touch screen.

Enter this into your phone (see your phone's handbook for more information).

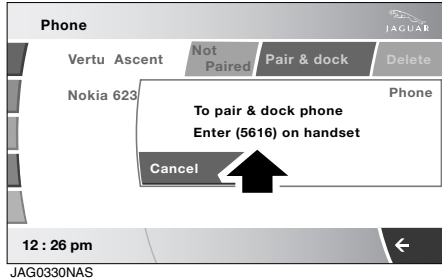

8. Your phone is now paired and docked ready for use, see **Making a Call** on page -217, see **Ending a Call** on page -217 and see **Receiving a call** on page -218.

Note:

- Once a cell phone has been paired and docked with the vehicle, the system will search for the last connected phone each time the ignition is switched ON. You do not need to manually pair and dock the phone with the vehicle every time you switch the ignition ON.
- If an incorrect code is entered, your cell phone should prompt you to enter the correct code.
- When the vehicle's entertainment system is active and the last connected phone comes into range of the vehicle, the system will attempt to connect to it.

If a phone call is ongoing when the phone is connected, the phone call will be automatically transferred to the vehicle's microphone and speakers.

Telephone

If you wish to avoid this occurring ensure that Bluetooth is turned off at the phone.

Pairing other phones

Up to five cell phones can be paired with the vehicle in the same way, however only one can be docked for use. For further information, see **SETTING UP YOUR PHONE** on page -211, see **Changing or deleting the phone** on page -213.

Changing or deleting the phone

Only one phone can be docked to the vehicle at any one time. To dock a different paired phone to the vehicle, follow these steps:

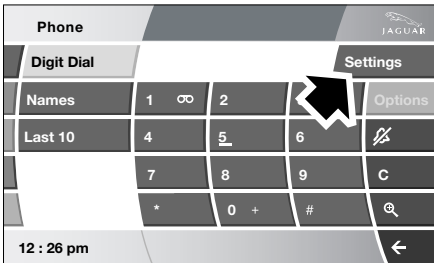
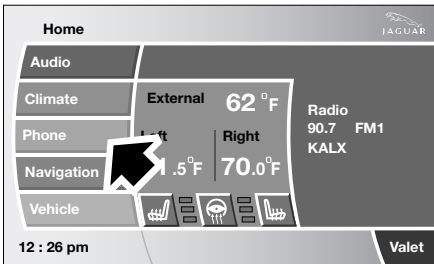

JAG0327NAS

From the home menu screen select **Phone**, then **Settings** then **Change phone**.

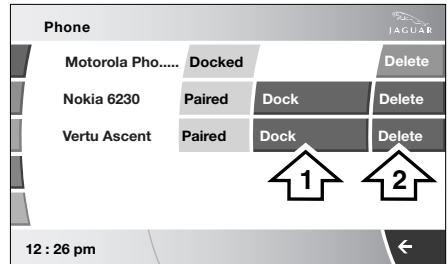
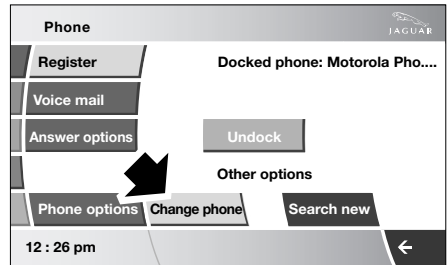

JAG0331NAS

1. Select **Dock** from the list of available phones.
2. Selecting **Delete** permanently removes the phone from the list. To use the phone again you have to pair and dock the phone to the vehicle, see **SETTING UP YOUR PHONE** on page -211.

Note: The phone does not need to be present to be deleted from the list.

Telephone

SETTINGS MENUS

Register

From the settings main menu selecting **Register** gives the options to **Undoct**, **Change phone** or **Search new**, for further information, see **SETTING UP YOUR PHONE** on page -211 see **Pairing other phones** on page -213 or see **Changing or deleting the phone** on page -213.

Voice mail

You can set up your voice mail to be accessed via the touch-screen. The voice mail (network service) option is an answering service where callers who are unable to reach you can leave you messages.

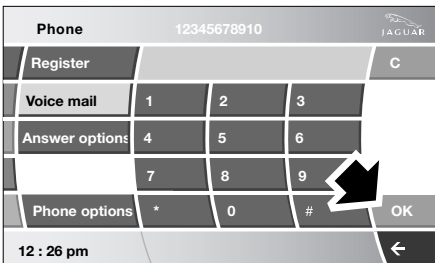
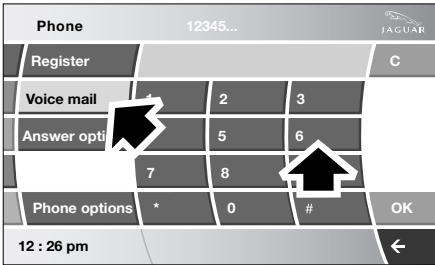

JAG0333NAS

Select **Voice mail** enter the number provided by your service provider and press **OK**. This number is stored in the system and used to retrieve any voice mail messages.

Retrieving voice mail

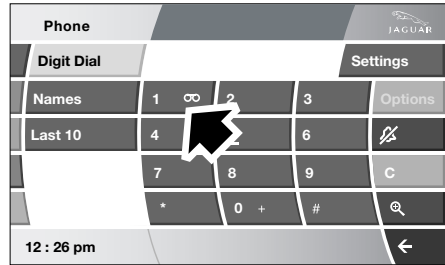

JAG0334NAS

To listen to your voice mail messages press and hold **1**.

The voice mail features can be used as if dialled from the cell phone.

Answer options

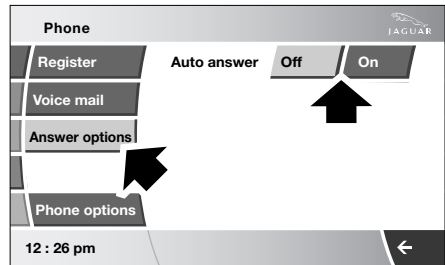

JAG0335NAS

1. Select **Answer options**.

2. Auto answer.

If automatic answer is on the call will automatically answer after a few seconds.

Select **Off** or **On**.

Telephone

Phone options

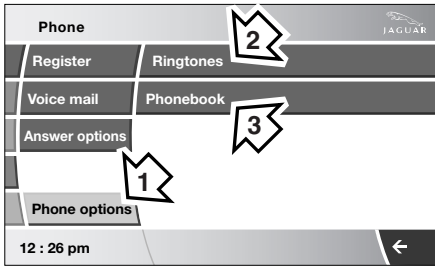

JAG0336NAS

1. Select **Phone options 1**.
2. **Ringtones** (Ringtone options).
3. **Phonebook** (Phonebook options).

Ringtones

Four ringtones are available (for in vehicle ringing) or you can use your cell phone's own ring tone:

Select **Ringtones 2**, Select **Portable's inband tone** to use your cell phones ringtone.

Note: *Not all phones support inband ringing.*

Note: *If the phone is set to silent or vibrate, inband ringing may not be available.*

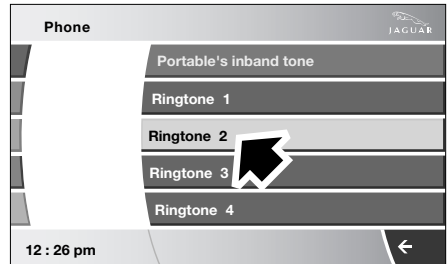
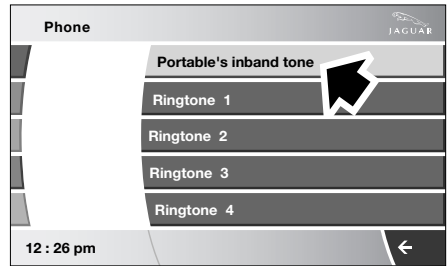

JAG0337NAS

Or select **Ringtone 1, 2, 3 or 4** to use a Jaguar preset ringtone.

Note:

The system will store the ring tone setting associated with each cell phone i.e. can be set for each paired cell phone.

Phonebook

The phone book option **3**, refer to the illustration on the previous page, allows you to automatically download your cell phones directory, erase it from the vehicle's memory or refresh it.

The system can store a maximum of 750 entries although this figure varies, depending on the type of cell phone used, see **Phonebook capacity** on page -217.

Telephone

Note: It may take several minutes to copy the phone book to the vehicle, depending on the phone and number of entries stored. The telephone system may not be operational during this period.

Auto download

Any phone numbers stored in your cell phone book can be copied to the vehicle's phone system.

If **auto download** is ON, the cell phone phonebook will be transferred to the vehicle every time the phone is connected (docked).

This feature will only work on phones that support AT Phonebook Profile, refer to your phone's handbook.

To change auto download: Select **Phone options 1**. Press **Phonebook 3**, see **Phone options**.

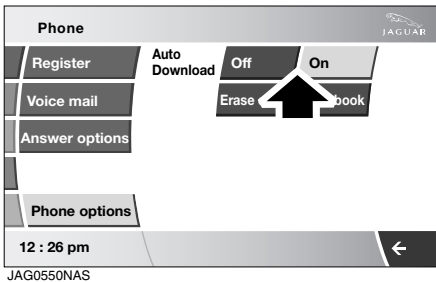

Select **Off** or **On**.

Erase entire phonebook

To erase the entire phone book directory:

Select **Phone options 1**, see page see **Phone options** on page -215. Press **Phonebook 3**.

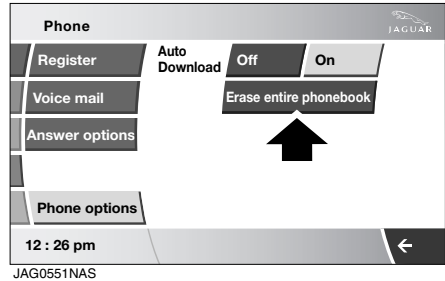

Select **Erase entire phonebook**.

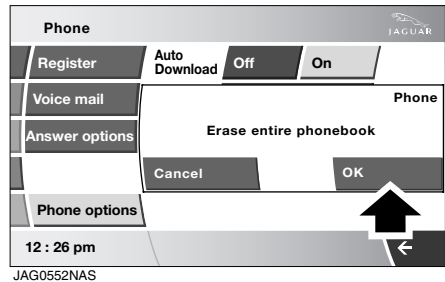

A pop-up window alerts you, that you are about to **Erase entire phonebook**. Select **OK** to remove all names from the vehicle directory.

To delete one or more names but not all, see **Names** on page -218.

Note:

This feature deletes phonebook entries stored in the vehicle memory and not those stored in the cell phone memory.

Telephone

Phonebook capacity

Certain cell phones store the phone book in two different areas, the SIM card and the phone memory. Where possible the vehicle will display both SIM card and phone memory entries up to a maximum of 750 entries. With some cell phones, the number of entries from one or both of these areas may be restricted, it is not always possible to transfer addresses stored in one or both of these areas.

The number of entries displayed is dependant upon the number of SIM and phone memory entries support by the cell phone.

Note: Certain cell phones do not allow phone book entries stored on the SIM card to be transferred via Bluetooth. However, it may be possible to transfer the SIM phone book to the cell phone's memory, before copying it to the vehicle phone book. Refer to your cell phone manual for more information. It is advisable to remove duplicate and blank entries from the cell phone before the phone book is downloaded.

USING YOUR PHONE

Making a Call

Before you make a call, your cell phone must be connected or paired and docked with the vehicle's Bluetooth system, see **SETTING UP YOUR PHONE** on page -211

From the Home menu screen select **Phone**.

Key in the phone number, including the area code, if applicable. The number will be displayed, press the **connect** icon.

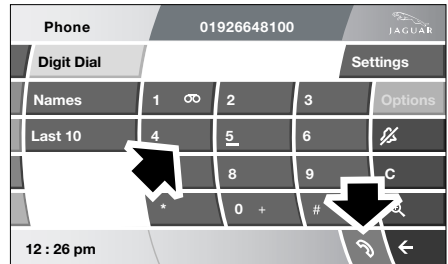
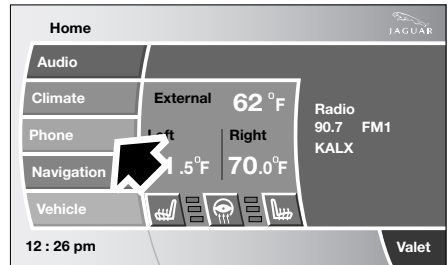

JAG0342NAS

Changing a phone number

When dialling a number, you can change the phone number shown on the touch screen display using the **C** button.

A momentary press erases any single digit, a long press erases the complete number.

Ending a Call

The preferred method to end a call is to use the hands-free controls on the steering wheel, see page 220.

Telephone

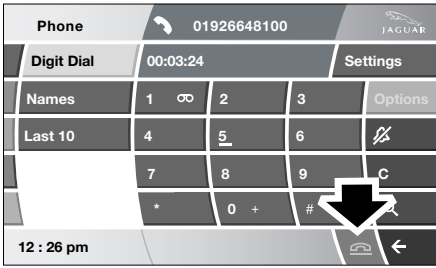

JAG0343NAS

Alternatively, to end a call press **end call** icon.

Receiving a call

If the audio system is in use when the phone becomes active, the audio system source is suppressed for the duration of the call.

If automatic answer has been programmed the call will automatically answer after a few seconds, see **Answer options** on page -214.

To answer

The preferred method to accept an incoming call, if **auto answer** is not active, is to use the hands-free controls on the steering wheel, see page 220. Alternatively, you can accept or reject the incoming call from the pop-up displayed on the touch-screen.

In-call options

When in a telephone call, **Options** may be selected to **Microphone mute** or **Privacy**.

Microphone mute: This will mute your telephone microphone so that the receiver of the call cannot hear you.

Privacy: Allows the use of the cell phone itself and only sends the audio to the cell phone speaker not the vehicle speakers.

Note: Some phones will switch off the Bluetooth link to the vehicle when in Privacy mode.

Ending a received call

To end the call, see **Ending a Call** on page -217 above.

Names

Directory name search and Deleting names

From the Home menu screen select **Phone**.

Select **Names**.

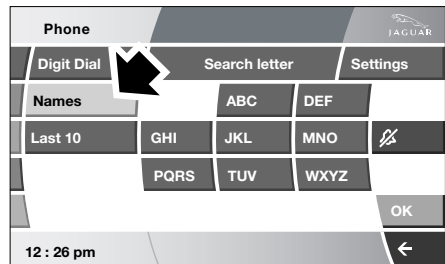
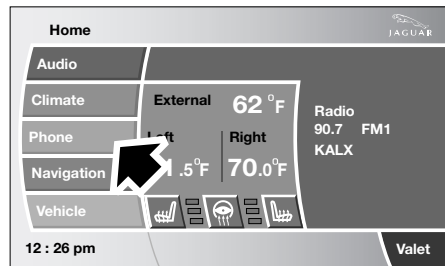

JAG0344NAS

Telephone

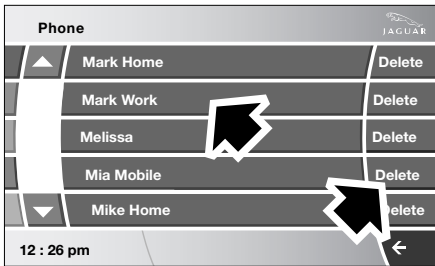
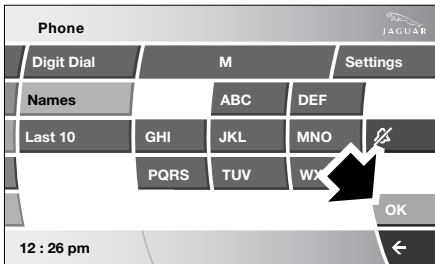
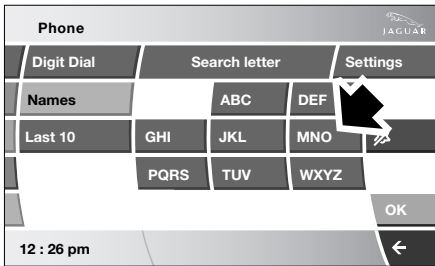

JAG0345NAS

1. Using the keyboard select the first letter of the contact name.
If name begins with the second or third letter on the button, press the button two or three time respectively.
For example, if the name required was Oliver, the **MNO** button should be pressed three times.
2. Select **OK**.
3. Select the desired name to make a call. Or select **Delete** to remove the name from the directory.

Last 10 option

The Last 10 option allows you to view the last 10 calls made, received or missed.

From the home menu screen select **Phone**.

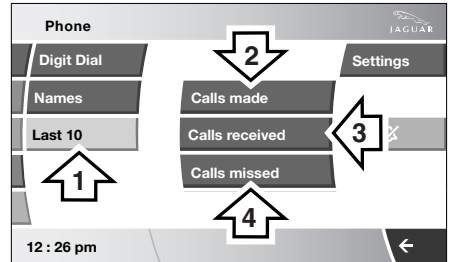

JAG0346NAS

1. Select **Last 10**.
2. Select **Calls made**.
3. Select **Calls received** or
4. Select **Calls missed**.

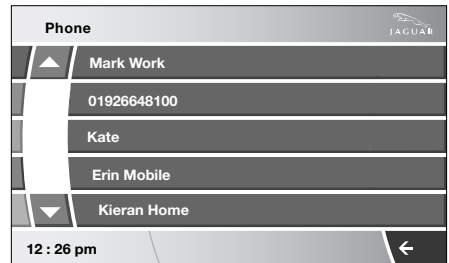

JAG0347NAS

The search fields are opened and a list of calls made, received or missed are listed, with the most recent at the top.

To make or return a call select the name from the list, your call will be routed automatically.

Telephone

Note:

The vehicle will display the list in the order that they are sent from the cell phone. Some phones may arrange the list in reverse or other order.

STEERING WHEEL CONTROLS

Four system adjustment controls are situated on the left-hand side of the steering wheel, duplicating functions of buttons on the touch screen. The preferred method of use is by these buttons to minimise driver distraction.

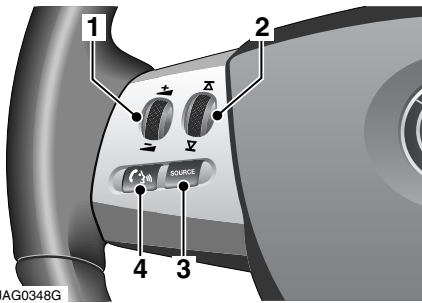

1. Scroll up/down to increase or decrease volume.
2. Scroll up/down to next/previous memory location.
3. SOURCE.
4. Press and hold to access phone mode.

Momentarily press and release to exit phone mode.

Making/Ending a call

To dial:

Key in the phone number, including the area code. The number will be displayed.

To connect press:



on the steering wheel or



on the touch screen.

To end the call press:



on the steering wheel or



on the touch screen.

Continuity of calls

Whilst in a call, the call remains connected if the vehicle is in **convenience mode**. When the call ends, another call cannot be made or received through the vehicle system unless the ignition system is ON and the touch-screen system active (START/STOP button pressed).

Telephone

Other features

Do not disturb mode

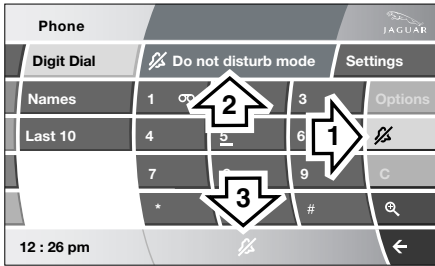

If you do not wish to be disturbed by incoming phone calls press the bell icon **1** on the touch screen. A visual representation will be displayed on the touch screen to advise the driver that Do not disturb mode is selected **3** and **Do not disturb mode** will be visible when in telephone mode (**2**). Any incoming calls will be rejected or diverted to voice mail, see 214.

Keyboard zoom

This option allows the user to increase the keyboard size.

When making a call using your numerical key pad displayed on the touch screen, the zoom icon becomes selectable.



JAG0353NAS

Select the zoom icon to enlarge the keypad size.

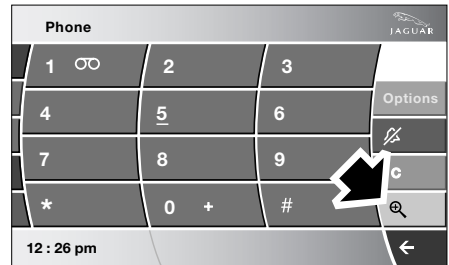

JAG0354NAS

Select the zoom icon again to reduce the size.

Emergency Equipment

FIRE EXTINGUISHER



WARNING:

Do not use a fire extinguisher closer than 2.4 m (8 feet) to the base of a liquid fire as the force may splatter the burning liquid to the surrounding area.

Dealer Fitted Fire Extinguisher

Your Jaguar Dealer can supply and fit one.

Factory Fitted Fire Extinguisher

Mexican vehicles have a factory fitted fire extinguisher which contains 1.0 kg (2.2 lb) of BC powder pressurised with nitrogen to a working pressure of 12 bar (180 psi) at 20°C (68°F).

This extinguisher can be used on liquid fires, electrical equipment fires and, if no explosion risk, gasoline fires.

To operate the fire extinguisher, follow the instructions as stated on the extinguisher.

Do not test the fire extinguisher prior to use. Partial discharge will render the extinguisher inoperative.

Maintenance

Every six months:

- Remove the extinguisher from its bracket and check that the nozzle is clear.
- Check that any fitted safety devices are secure.
- If fitted, check pressure gauge is reading within limits. If the gauge is indicating incorrect limits, the extinguisher may not work in an emergency. Seek qualified assistance immediately.

WARNING TRIANGLE

A warning triangle, designed to international standards, is standard equipment in certain countries.

Coupe: The warning triangle is stowed under the luggage compartment load floor.

Convertible: The warning triangle is stowed in the luggage compartment lid.

Mexico only: The two warning triangles are stored in a bag stowed in the luggage compartment.

In an emergency, remove the triangle(s) and unfold its stand legs. Place the triangle(s) in the road in accordance with local traffic regulations to give oncoming traffic warning of an immobilised vehicle.

Hazard warning lights must be used with the warning triangle.

FIRST AID KIT

Your Jaguar Dealer has first aid kits available.

Status After a Collision

DRIVING AFTER A COLLISION

If the vehicle is involved in a collision, the functionality of the vehicle could be reduced.

Depending upon the severity of the collision the following vehicle functions may come into effect:

- engine shut down
- inertia switch tripped, which cuts off the fuel pumps
- doors unlock
- hazard and interior lights come on (the hazard lights will remain on until the inertia switch is reset)
- the message centre will display **INERTIA SWITCH TRIPPED**
- exterior lights will maintain their state.

ATTEMPTING TO START THE VEHICLE



WARNING:

To reduce the risk of fire or personal injury, do not under any circumstances, attempt to start the vehicle if you see or smell fuel.

The inertia switch may have been tripped by the collision. This will cut off the fuel pumps. The switch must be reset before the engine will start.

Resetting the switch

If no fuel leak is apparent:

1. Press the engine START/STOP button, without pressing the brake pedal, to turn the ignition back to **convenience mode** (ignition OFF). Wait for approximately 10 seconds.

2. Press the engine START/STOP button again, without pressing the brake pedal, to turn the ignition ON. Wait 30 seconds.
3. Make a further check for fuel leaks.
4. Press the START/STOP button with the brake pedal depressed to start the engine as normal.

MOVING THE VEHICLE

If the engine starts, the vehicle may be moved carefully to a position of safety. Do not move the vehicle further than necessary.

Recovery

Even if the vehicle appears driveable after the collision, it should not be driven or towed. Concealed damage could make the vehicle impossible to manoeuvre. See page 224.

Vehicle Recovery

TRANSPORTING THE VEHICLE

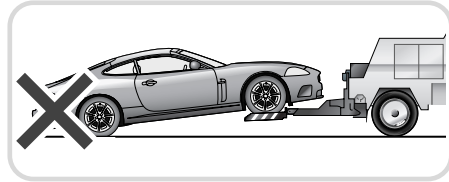
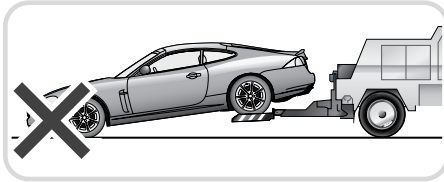
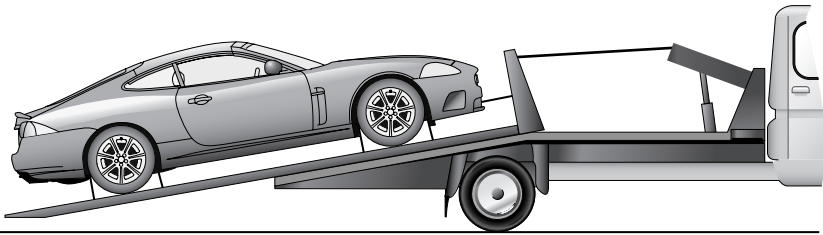

JAG0355G

Jaguar strongly recommend that the vehicle is recovered by use of a slide-bed recovery transporter only.

Caution:

- **Ensure that the recovery team do not tow with sling-type, spectacle-type or towing dolly equipment as damage to the front or rear underside bodywork may result.**
- **If the vehicle has an inoperable transmission, to prevent further damage, it must be towed with the rear wheels clear of the ground.**

Transporting

If the vehicle is being transported the parkbrake must be applied, the wheels chocked and the gear selector lever moved to position **N** or **D** but never to **P**.

While the vehicle is being loaded, the Jaguar Smart Key should be placed in the starter control unit. This will prevent the steering lock activating.

The vehicle must be securely tied down to the transporter or trailer. Use straps on the front wheels and tires to secure the vehicle for transportation.

The towing eye is not designed for securing the vehicle during transportation.

Vehicle Recovery

Vehicle failure



WARNING:

Without the engine running, the brake servo and power steering pump cannot provide assistance: greater effort will therefore be required to operate the brake pedal and turn the steering wheel. Longer stopping distances will also be experienced.

The removable towing eye is primarily for emergency use when towing for short distances, e.g. removing the vehicle if it is causing an obstruction or for winching the vehicle onto a recovery transporter. To prevent damage while the vehicle is being towed with the rear wheels on the ground, towing distance must be restricted to 0.8 kilometres (0.5 miles). Towing speed must not exceed 48 km/h (30 mph).

When being towed, the transmission must be in neutral (**N**) with the ignition system switched to **convenience mode** to release the steering lock and render the indicators, horn and brake lights operational.

Vehicle Recovery

TOWING POINTS

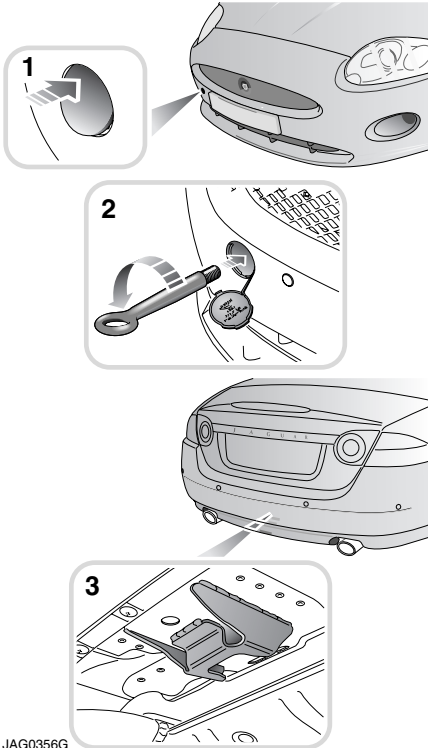

JAG0356G



WARNING:

Avoid body contact with a hot exhaust pipe when fitting any equipment to the rear towing points.

Caution:

- The towing eye is not suitable for solid bar towing.
- Care must be taken to avoid damaging the bumpers and front apron.

A screw-in front towing eye is provided in the luggage compartment with the jack. The towing eye has a left-hand thread and must be screwed in a counter-clockwise direction when fitting.

The front towing point is located behind a plastic cover on the left-hand side of the vehicle (as viewed from the front).

1. To access the towing point, press the plastic cover on the top to unclip. Remove the cover.
2. Screw the towing eye into the vehicle, right up to the shoulder.
3. The rear tie-down point is in the centre of the vehicle to the rear of the exhaust silencer.

Use this point only when the vehicle is to be towed rearwards on straight level ground for the least amount of distance possible or loading onto a recovery vehicle.

Vehicle Care



WARNING:

Many liquids and other substances used in vehicles are poisonous and should never be consumed and must be kept away from open wounds. These substances include antifreeze, brake fluid, fuel, windshield washer additives, lubricants and various adhesives.

Caution: Read individual product warnings before using any car cleaning or washing products.

CLEANING PRODUCTS



WARNING:

Dry cleaning fluids may be toxic or flammable. Take adequate precautions when handling these products.

Brush and clean the interior regularly. Use a vacuum cleaner where possible to remove all dust from the interior and trim.

CLEANING THE EXTERIOR

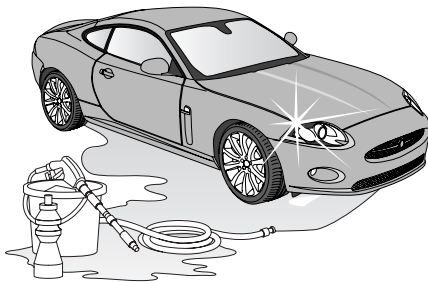

JAG0437G

Washing your vehicle

For best results, do not wash the vehicle under strong sunlight. Always allow the vehicle to cool down before washing.

Do not use a dry cloth to wipe dirty paintwork. Dust and gritty substances are abrasive and will scratch the paintwork. Remove dirt using a cellulose sponge and plenty of warm (never hot) water. Rinse off with clean water and dry using a clean, damp chamois leather.

Do not use household soaps or detergents. The use of Jaguar Vehicle Shampoo is recommended.

Using an automatic wash

Caution:

- Ensure that **AUTO**, wipers, is not selected when entering a car wash or damage to the wiper blades and arms can occur as they will operate in the car wash.
- Ensure that the audio system is turned **OFF** so that the aerial is retracted.

Note: Regular use of automatic car washes tends to dull the lustre of the paintwork.

After leaving the car wash, switch on the windshield wiper immediately to remove water and prevent a build up of wax.

Convertible top fabric

Caution:

- Do not use an automatic car wash that has rotating brushes. The action of the brushes may damage the exterior fabric or the seals of the convertible top.
- Do not use spot cleaners, chemical dilutants or any organic cleaners. If in doubt, contact your Jaguar Dealer.

Vehicle Care

To maintain the appearance and condition of the convertible top, the recommendations given below should be followed. This is of particular importance in the case of light coloured tops.

Do not leave the top in the open (folded) position for longer than is necessary, as in certain circumstances permanent soiling along the folds may occur.

Cleaning: Every 1 600 km (1 000 miles) vacuum clean and wash the convertible top using the Jaguar Soft Top Cleaning Kit, carefully following the instructions enclosed.

Reproofing: Every 8 000 km (5 000 miles) reproof the top using the solution in the cleaning kit, carefully following the instructions enclosed.

Preparation for Winter

Before the onset of Winter, it is advisable to coat the convertible top seals and respective body seals with a compound, such as Carbaflo KSP 105, to aid operation in freezing conditions.

This action will need to be repeated at the start of each Winter to maintain protection.

Care must be taken so that the compound does not come into contact with the convertible top material. For further advice you should contact your Jaguar Dealer.

Aerial care

Regular cleaning with a special aerial cleaner, will ensure smooth and reliable operation of the aerial.

In freezing conditions check that no ice has formed over the top of the aerial, which could prevent it being raised and cause damage to the motor.

The Jaguar Aerial Cleaning Kit contains the necessary maintenance items.

Using a high pressure washer

Caution: Some high pressure cleaning systems are sufficiently powerful to penetrate door and window seals and damage rubbing strips and locking mechanisms. Never aim the water jet directly at heater air intakes, body seals, the convertible top, or at any component that might easily be damaged.

When salt is used on the roads, wash the vehicle immediately after encountering such conditions. Clean undersides and wheel arches using a high pressure jet.

Underhood cleaning

Caution: Do not use a high pressure washer or steam cleaner in the engine compartment. Damage to components could occur.

Glass surfaces

Clean the rear window with a soft cloth to avoid damaging the heating element. DO NOT scrape the glass or use any abrasive cleaning fluid.

Mirror glass is particularly susceptible to damage. Wash with soapy water. DO NOT use abrasive cleaning compounds or metal scrapers to remove ice.

The following products will ensure glass surfaces and windshield wipers are kept in good condition:

Jaguar Screen Clean Paste – Apply to the exterior of the windshield only to ensure effective operation of the windshield wiper.

Jaguar Glass Cleaner – Interior and exterior of all other glass surfaces.

Vehicle Care

Jaguar Screen Wash – Washer reservoir additive.

Jaguar Winter Care Kit comprising de-icer, ice scraper, anti-mist wipe cloth and aerial cleaner – for use in adverse weather conditions.

Cleaning the rear screen

To avoid damaging the heating elements, when cleaning the inside of the rear screen use only a soft damp cloth or chamois leather. Do not use solvents or sharp objects to clean the glass.

Care of alloy road wheels

The alloy road wheels are covered with a protective anti-corrosion coating. To prevent corrosion it is essential that this coating is not damaged.

When removing or fitting tires always advise the tire fitter to treat the alloy wheels with great care. Tire levers must not be used.

Wash the wheels regularly with soap and water to avoid an accumulation of particles. In salty conditions the wheels should be cleaned more frequently.

Jaguar acid-free wheel cleaner can be used to remove heavy soiling. Do not use non-approved acid based cleaners.

Removing Grease and Tar

Remove grease or tar with Jaguar Tar Remover or methylated spirit (alcohol). White spirit is also effective, but must not be applied to rubber, particularly the windshield wiper blades.

Bird Droppings

Do not allow bird droppings or tree sap to harden. Remove from paintwork immediately with a lukewarm soap and water solution.

Polishing

For maximum protection against road dust, salts, industrial fall-out etc., it is recommended that the vehicle is polished regularly using Jaguar polish and a polishing cloth.

Note: *The vehicle's brightwork should be cleaned in the same way as the paintwork: Chrome polish or other abrasive cleaners must not be used.*

CLEANING THE INTERIOR

Caution: To prevent airbag damage, the steering wheel centre pad and other areas containing airbags should only be cleaned sparingly with a damp cloth, warm water and a non-detergent soap. Do not allow these areas to be flooded with chemical solvents, liquids, furniture cream or polishes.

Leather

Leather is an easy to maintain natural product, however, dust and substances can penetrate the pores and crease the leather, causing surface wear and brittleness.

To prevent ingrained dirt and staining, inspect the seat upholstery regularly and clean every one to two months as follows:

- Wipe off fine dust from the seat surfaces using a clean, damp, non-coloured cloth. Change frequently to a clean area of cloth to avoid abrasive action on the leather surface. Avoid over-wetting.
- If this is not sufficient, use a cloth which has been dampened with warm soapy water and then wrung out. Use only mild non-caustic soap.

Vehicle Care

- Use Jaguar Leather Cleaner for heavily soiled areas. Dry off and rub with a clean soft cloth, changing surfaces regularly.

When staining (e.g. from clothing) or spillage occurs, clean the affected area immediately as described above.

Use Jaguar Leather Cleaner several times a year to maintain its appearance and suppleness. The cleaner will nourish and moisturise and help to improve the surface protective film against dust and substances.

- Do not use solvents. Do not use detergents, furniture polish or household cleaners. While these products may initially give impressive results, their use will lead to rapid deterioration of the leather and will invalidate the warranty. Jaguar recommend a basic set of products that have been specially selected for the type of leather in your vehicle.
- Dark clothing may stain leather seats just like other upholstery products.
- Sharp objects such as belts, zip fasteners, rivets, etc. can leave permanent scratches and scratch marks on the leather surface.
- Unless spillages such as tea, coffee or ink are washed away immediately, permanent staining may have to be accepted.

If a valet service is used, ensure that the specialist concerned is aware of, and follows these instructions precisely.

Cloth and fabric

Caution:

- **Never use soap, ammonia, bleach or other cleaners intended for use on hard surfaces.**
- **Do not use upholstery cleaner on electrical equipment such as facia switches.**
- **When cleaning around electrical equipment such as switches, ensure that fluids do not leak into any gaps around the components or between panels or trim.**

Use Jaguar Upholstery Cleaner, following the instructions. Do not over wet.

Removing stains

Most stains on woollen fabric can be removed if treatment is carried out immediately, before the stain has a chance to dry-in.

Most stains can be treated with one of three cleaning fluids: Jaguar Upholstery Cleaner, dry cleaning fluid or clean water. Follow the instructions on the package.

Carpet and mats

Marks or stains can be removed by gentle scrubbing with a weak solution of soap and warm water.

For more stubborn stains a commercially available carpet cleaner should be used.

Vehicle Care

Floor mat retention

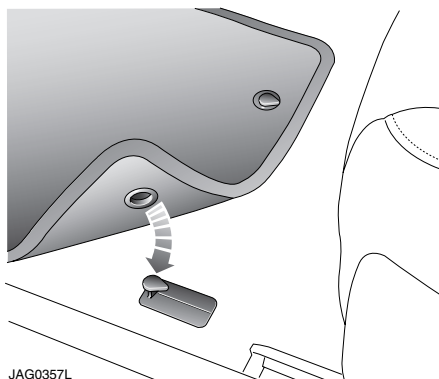

The driver's floor mat must be correctly positioned and secured under the tongues on the retention posts (only one post shown). Ensure that the mat does not interfere with the operation of the accelerator or brake pedal.

REPAIRING MINOR PAINT DAMAGE

Paint chips

Scratches and chips should be touched in before weathering action begins. Inspect the paintwork immediately after the vehicle has been washed.

Maintenance

GENERAL INFORMATION

Protect the environment

We must all play our part in protecting the environment. Correct vehicle usage and disposal of waste cleaning and lubrication materials are significant steps towards this aim.

Avoid using high engine speeds. This will protect your engine, reduce fuel consumption, lower the engine noise level and help towards reducing the environmental burden.

Dispose of used parts and fluids at your local authorised waste disposal facilities.

Regular Servicing

Caution: Severe damage to the electrical system and electronic components can occur if any attempt is made to diagnose faults in the electrical system using conventional diagnostic equipment (for example, the use of test lamps or low impedance voltmeters). The fitting of any electrical accessory should only be entrusted to a Jaguar Dealer.

Regular maintenance and servicing is the responsibility of the owner. Failure to implement maintenance at the recommended intervals could result in deterioration of vehicle performance and possible infringement of regulations.

Your Jaguar Dealer will be pleased to arrange periodic servicing in accordance with the Passport to Service (USA and Canada) or Service Portfolio (Mexico).

Warranty - USA and Canada

The Passport to Service contains warranties applicable to the vehicle, which include:

- The Limited Vehicle Warranty.
- The Emission Control System Warranty and covered parts list.
- The Corrosion Warranty.

Tires are not warranted by Jaguar Cars Limited, but by the specific manufacturer of the tires on the vehicle. Details of tire warranties are included in the vehicle literature pack.

Warranty - Mexico

The Warranty Benefits booklet contains warranties applicable to the vehicle, which include:

- The Limited Vehicle Warranty.
- The Emission Control System Warranty and covered parts list.
- The Corrosion Warranty.

Owner maintenance

In addition to the routine services and inspections, a number of simple checks must be carried out more frequently. You can carry out these checks yourself.

Any significant or sudden drop in fluid levels, or uneven tyre wear, should be reported to a Jaguar Dealer/Authorised Repairer without delay.

Daily checks

- Operation of lamps, horn, direction indicators, wipers, washers and warning indicators.
- Operation of seat belts and brakes.

Maintenance

- Look for fluid deposits underneath the vehicle that might indicate a leak.

Condensation drips from air conditioning is normal.

Weekly checks

- Engine oil level.

Note: *The engine oil level should be checked more frequently if the vehicle is driven for prolonged periods at high speeds.*

- Brake fluid level.
- Power steering fluid level.
- Screen washer fluid level.
- Tyre pressures and condition.
- Operate air conditioning.

Monthly

Wiper blades - Check the quality of the wipe. If smearing or juddering is evident, clean the windshield and renew the wiper blades.

Maintenance

OPENING AND CLOSING THE HOOD



WARNING:

When working within the engine compartment, take care to avoid contact with moving parts and hot components.

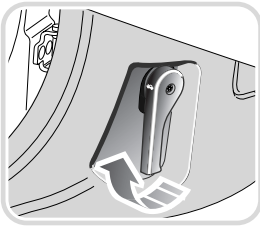
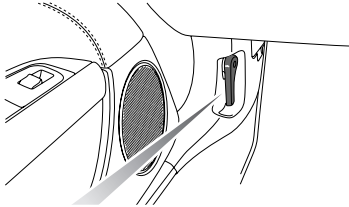

JAG0359G

The hood lock release control is below the fascia on the left-hand side of the vehicle.

To open: Release the hood lock by pulling the lever. Reach across to the centre rear edge of the hood and lift. The gas filled struts will assist raising the hood, and retain it in the fully open position.



WARNING:

Before closing the hood ensure that no one is obstructing the closing area and that hands and clothes are clear.

Caution: Do not press downward on the top of the hood to close it, especially within the final centimetres (inches) of closing, as this may damage the hood.

Hood latching: Close the hood to within a distance of 30 cm to 35 cm (12 to 14 inches) of the fully closed position, then let go to allow the hood to shut.

To check that the hood is closed, pull the hood upwards to ensure that both the right-hand and left-hand latches are engaged.

Maintenance

ENGINE COMPARTMENT OVERVIEW

Normally aspirated engine

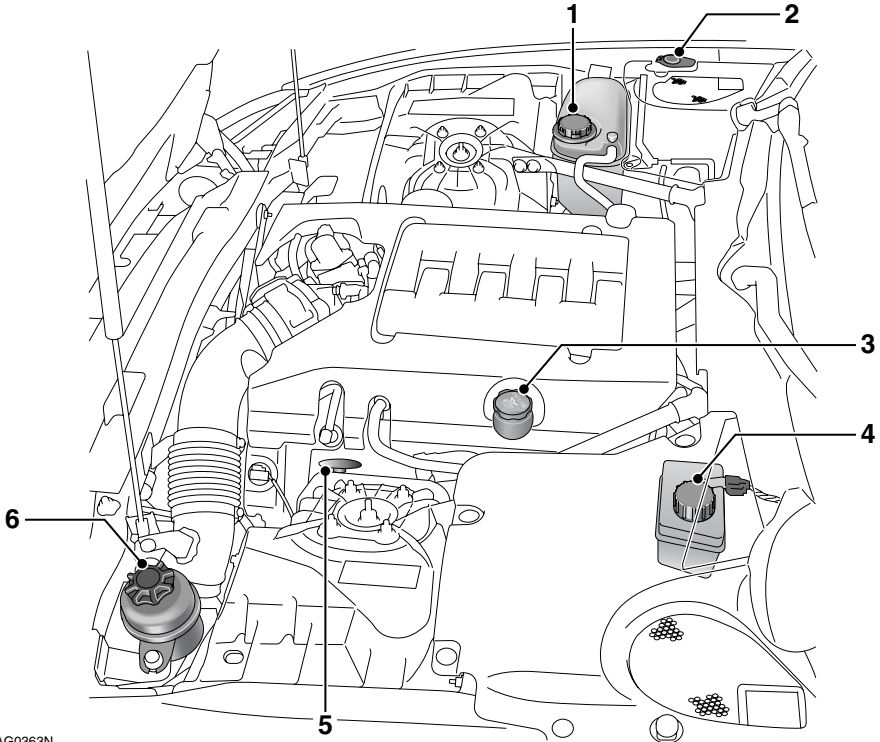

JAG0363N

1. Coolant reservoir.
2. Windshield and headlamp washer reservoir.
3. Engine oil filler.
4. Brake reservoir.
5. Engine oil dipstick.
6. Power steering reservoir.

Maintenance

Supercharged engine

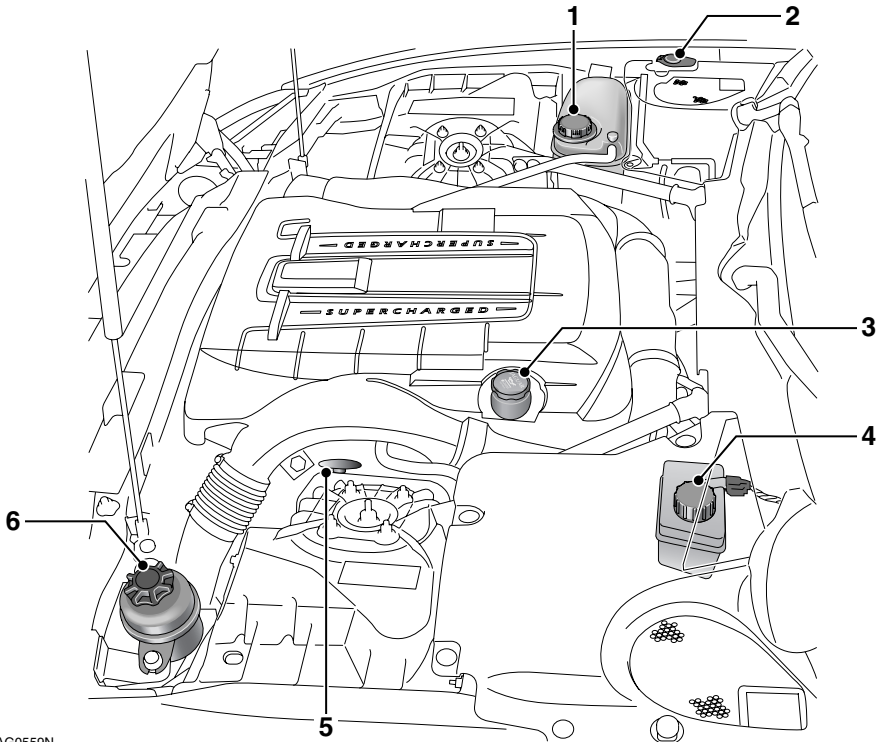

JAG0559N

1. Coolant reservoir.
2. Windshield and headlamp washer reservoir.
3. Engine oil filler.
4. Brake reservoir.
5. Engine oil dipstick.
6. Power steering reservoir.

Maintenance

ENGINE OIL CHECK

Caution:

- If the message **ENGINE OIL PRESSURE LOW** is displayed, stop the engine immediately and seek qualified assistance. Do not start the engine until the cause has been identified and rectified.
- Your vehicle's warranty may be invalidated if damage is caused by the use of improper engine oil. Low quality or obsolete oils do not provide the protection required by modern, high performance engines. Failure to use an oil that meets the required specification could cause excessive engine wear, a build up of sludge and deposits and increased pollution. It could also lead to engine failure.
- Do not use oil additives of any type as engine damage could occur. Use only specified lubricants.

Engine oil consumption

A certain amount of oil consumption is normal. The rate of consumption will depend on the following:

- the quality and viscosity of the oil
- climatic conditions
- the speed at which the engine is being operated
- road conditions.

Drivers should expect above normal consumption when the engine is new.

Check the oil level regularly with the vehicle on flat, level ground.

Check the oil level with the engine completely cold.

To check engine oil level

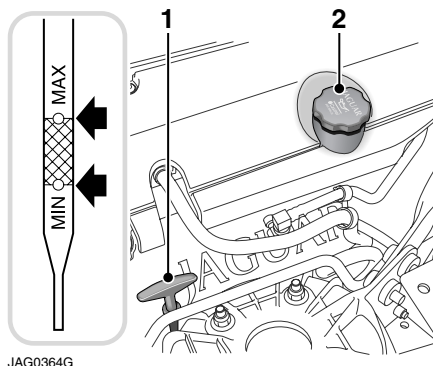

JAG0364G

Remove the dipstick **1** and wipe clean with a lint free cloth. Replace fully, then withdraw the dipstick. If the oil level is above the lower of the two dots on the dipstick then no additional oil is required.

If the oil level is at or below the lower of the two dots, remove the oil filler cap **2** and add oil, to the quantity and specification shown on page 238.

Refit the filler cap and hand tighten securely until one click is heard.

Maintenance

Recommended engine oil
Jaguar recommends



When the oil level is at the lower dipstick mark, add 1litres (1.1 US quart) of oil.

Oil specification



API SM and ILSAC GF-4.

When topping up between oil changes, make sure that you use oil that has the correct quality level (API service) and viscosity grade.

Note: For maximum fuel economy, 5W-30 oil is recommended.

Engine oil temperature ranges

For climates ranging from -35°C (-31°F) to $+50^{\circ}\text{C}$ ($+122^{\circ}\text{F}$), the following oil viscosities may be used:

0W-30 will protect from -35°C (-31°F) to $+35^{\circ}\text{C}$ ($+95^{\circ}\text{F}$).

5W-30 (preferred) will protect from -30°C (-22°F) to $+35^{\circ}\text{C}$ ($+95^{\circ}\text{F}$).

0W-40 will protect from -35°C (-31°F) to $+50^{\circ}\text{C}$ ($+122^{\circ}\text{F}$).

5W-40 will protect from -30°C (-22°F) to $+50^{\circ}\text{C}$ ($+122^{\circ}\text{F}$).

ENGINE COOLANT CHECK



WARNING:

- It is unsafe to run the engine in an overheated condition.
- The radiator cooling fans may continue to run after the ignition has been switched off but will automatically switch off when the engine has cooled sufficiently.
- Do not remove the coolant reservoir filler cap while the engine is hot. If it is essential, then protect your hands against escaping steam. Slowly turn the cap counter clockwise to allow the steam pressure to escape completely before removing the cap.

Caution: If persistent coolant loss is noticed, seek qualified assistance immediately.

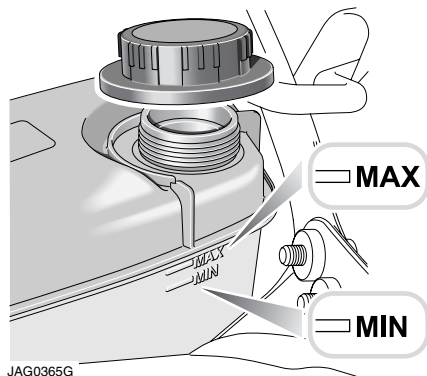

Check the level only when the engine is cold. The coolant level should be between the **MAX** and **MIN** indicators. If persistent coolant loss is noticed, seek qualified assistance immediately.

Maintenance

If the message centre displays the message **ENGINE OVERHEATING**, pull over and allow the engine to idle for five minutes and then switch off for ten minutes. Switch on and provided that the warning does not recur, continue your journey avoiding harsh acceleration. Seek qualified assistance as soon as possible.

Topping up



WARNING:

- **Do not allow antifreeze to make contact with skin or eyes. If this should happen, rinse the affected area immediately with plenty of water.**
- **Coolant fluid is toxic and in concentrated form is flammable. Observe all warnings indicated on the container.**

Caution: Antifreeze will damage paintwork. Wash off immediately if spillage occurs.

Top up with a mixture of 50% water and 50% antifreeze until the coolant is between the **MAX** and **MIN**. This 50/50% mixture gives frost protection for temperatures down to -40°C (-40°F). Use antifreeze to specification WSS M97B44, coloured orange, Extended Life Coolant.

Refit the filler cap and hand-tighten securely until one click is heard.

WASHER FLUID CHECK



WARNING:

- **Windshield washer fluid is toxic and in concentrated form is flammable. Observe all warnings on the washer solution container.**
- **Under no circumstances must cooling system antifreeze be used, since this will damage the paintwork.**

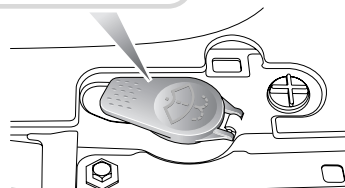
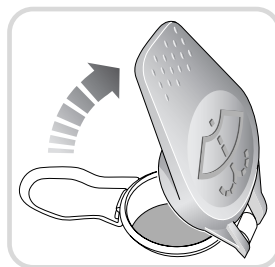

JAG0366G

The washer reservoir contains the fluid for the windshield washers and the headlamp powerwash system.

Fill with Jaguar Windshield Washer Fluid diluted with clean soft water as specified in the instructions on the bottle. Do not over fill.

Using a non-approved fluid may adversely affect the wiper blade rubber, resulting in ineffectual and noisy wiping.

Maintenance

Cold weather precautions

To prevent damage to the pump during freezing conditions, use Jaguar Windshield Washer Fluid at the strength shown on the bottle, for the anticipated ambient temperature.

Caution: State or local regulations on volatile organic compounds may restrict the use of methanol, a common windshield washer anti-freeze additive. Washer fluids containing non-methanol anti-freeze agents should be used only if they provide cold weather protection without damaging the vehicle's paint finish, wiper blades or washer system.

BRAKE FLUID CHECK



WARNING:

The fluid level will drop as the brake pads wear. If the level is very low the brake warning indicator will illuminate and a message **BRAKE FLUID LOW** will be displayed. Seek qualified assistance immediately. Do not drive the vehicle until the cause is rectified as driving under such conditions could result in extended stopping distances or complete brake failure.

Caution:

- While handling brake fluid, take extreme care; brake fluid can damage the vehicle paintwork.
- Always use fresh, clean fluid from a new container. Never introduce used brake fluid into the system.

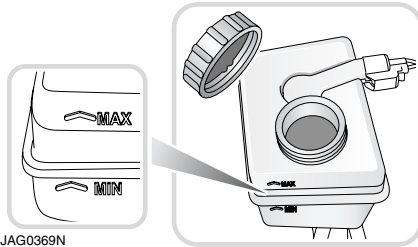
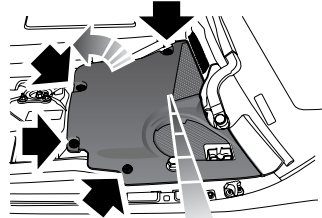
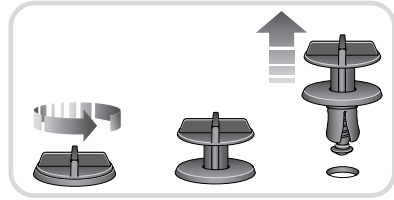

JAG0369N

The fluid is visible through the translucent casing of the reservoir and must be maintained at the **MAX** mark.

Topping up:

1. Remove the reservoir top cover.
2. Clean the reservoir and cap thoroughly with a lint free cloth to ensure that no foreign matter enters the reservoir.
3. Unscrew the filler cap and top up to the **MAX** level using brake fluid to specification **Shell DOT 4 ESL** or low viscosity DOT 4 brake fluid that meets ISO 4925 class 6 specification. Only fluid of this type and standard may be used.

Maintenance

4. Refit the filler cap securely and refit the cover.

If the level be very low, seek qualified assistance as soon as possible.

POWER STEERING FLUID CHECK

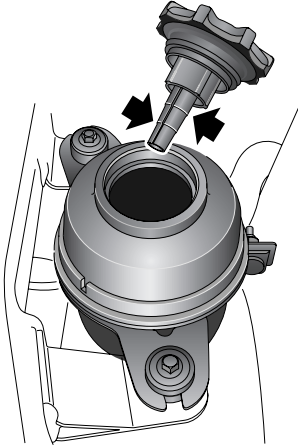

JAG0370G

Caution: It is imperative that the power steering system does not become contaminated in any way. Always use new fluid and clean the area around the reservoir neck both before and after topping up.

1. Check the fluid level when the engine is COLD and the vehicle is on a flat, level surface.
2. Wipe clean and remove the filler cap from the reservoir; take great care to prevent any foreign matter from entering.
3. Check that the fluid level is between the marks on the reservoir dipstick.
4. If necessary, top up with DEXRON III power steering fluid, DO NOT OVERFILL.
5. Refit the filler cap.

Vehicle Battery

BATTERY WARNING SYMBOLS

There is a label on the battery depicting a number of warning signs. The warning signs are as follows:



No smoking, no flames, no sparks (Red).



Shield eyes (Blue).



Keep away from children (Red).



Explosive gas (Yellow).



Battery acid (Yellow).

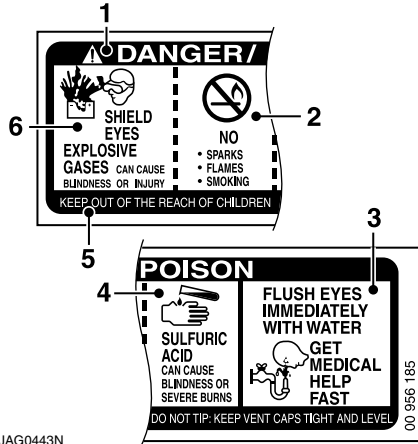

JAG0443N

1. DANGER/POISON
2. NO
 - SPARKS
 - FLAMES
 - SMOKING
3. FLUSH EYES IMMEDIATELY
GET MEDICAL HELP FAST
4. SULFURIC ACID can cause blindness
or severe burns
5. KEEP OUT OF THE REACH OF
CHILDREN
DO NOT TIP
KEEP VENT CAP TIGHT AND LEVEL
6. SHIELD EYES
EXPLOSIVE GASES CAN CAUSE
BLINDNESS OR INJURY

Vehicle Battery

BATTERY CARE



WARNING:

- The cell plugs and vent pipe must be in place at all times when the battery is in the vehicle. Failure to fit, or incorrect fitting of these items is potentially hazardous. Ensure that the vent pipe is free from kinks or damage.
- If battery acid comes into contact with skin or eyes immediately rinse with cold water and consult a doctor.
- Never charge or boost a frozen battery.
- Switch off ignition before disconnecting battery terminals. Always disconnect the ground terminal first and reconnect last.
- Do not let battery acid come into contact with painted surfaces or fabric.
- California Proposition 65: Battery posts, terminals and related accessories, contain lead and lead compounds. Wash hands after handling.

A low maintenance battery specifically designed for use with this vehicle is fitted in the luggage compartment.

In hot climates more frequent checks of the battery electrolyte level are required. If necessary, the battery cells can be topped up with distilled water.

The exterior of the battery should be occasionally wiped clean to remove any dirt or grease.

Note: Do not connect any 12 volt equipment, (for example, a 12 volt lamp), directly to the battery terminals. Use the accessory socket located in the glove box for connecting Jaguar approved accessories.

Replacement batteries



WARNING:

Only fit a replacement battery of the same type and specification as the original - other batteries may vary in size or have different terminal positions which could cause a fire hazard when connected to the vehicle's electrical system.

Battery disposal

Used batteries should be recycled. However, batteries are hazardous - you should seek advice about disposal from a Jaguar Dealer or your local authority.

USING BOOSTER CABLES



WARNING:

- Always wear appropriate eye protection when working with batteries.
- During normal use, batteries emit explosive hydrogen gas - ensure sparks and naked lights are kept away from the engine compartment.
- Do not attempt to start the vehicle if the electrolyte in the battery is suspected of being frozen.

Vehicle Battery

- **Make sure both batteries are of the same voltage (12 volts), and that the booster cables have insulated clamps and are approved for use with 12 volt batteries.**
- **Do not disconnect the discharged battery.**
- **Do not connect positive (+) terminals to negative (-) terminals, and ensure booster cables are kept away from any moving parts in the engine compartment.**
- **Take care when working near rotating parts of the engine.**

Caution:

- **If using a boost start vehicle, under no circumstances should the vehicles come into contact with each other. This could establish an earth connection, which may cause sparks and damage.**
- **Do not run the boost start vehicle's engine when boost starting a Jaguar vehicle. If the boost start vehicle's engine is running and the jump leads are disconnected, damage to the Jaguar vehicle's electrical system will result.**

This vehicle is fitted with automatic transmission. In the event of a discharged battery preventing a normal engine start, the vehicle cannot be started by pushing or towing. Either use booster cables connected to a booster battery (e.g. on another vehicle) or fit a fully charged battery.

Using booster cables (jump leads) from a donor battery, or a battery fitted to a donor vehicle, is the only approved method of starting a vehicle with a discharged battery. This procedure differs to that used to charge a battery, which should not be attempted with the battery connected to the vehicle.

Boosting from another vehicle



WARNING:

Do not use a 24 volt booster start system. These produce excessive voltage and can damage the vehicle's electrical system.

If a donor vehicle is to be used, both vehicles should be parked with their battery locations adjacent to each other. Ensure that the two vehicles do not touch.

Apply the parkbrakes and ensure that the transmission of both vehicles is set in neutral (**P** - park for vehicles with automatic transmission).

Ensure that both vehicles have all electrical services OFF.

Where the booster cables are of a different colour, e.g. red and black, use red for positive (+). This aids identification and helps to avoid crossing positive (+) to negative (-). Take extra care to avoid crossing the polarity when using cables of the same colour.

Vehicle Battery

Procedure for using booster cables

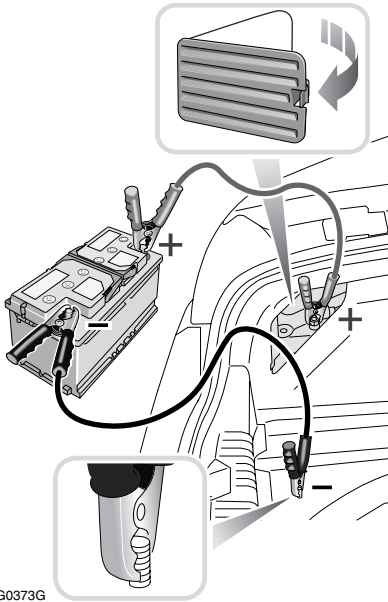

JAG0373G

The following procedure must be followed exactly:

1. Remove the left-hand side luggage compartment trim panel cover to access the vehicle battery positive (+) remote charge terminal, remove the protective cap from the terminal.
2. Attach one end of the red jump lead to the positive (+) terminal of the booster battery and the other end to the positive (+) remote charge terminal of the vehicle battery.
3. Lift the luggage compartment floor panel to reveal the spare wheel. Remove the protective cap from the negative (-) terminal of the vehicle battery remote charge terminal.
4. Attach one end of the black jump lead to the negative (-) terminal of the booster battery and the other end to the negative (-) terminal of the vehicle battery remote charge terminal.
5. Start the disabled vehicle. Allow the engine to idle for five minutes before disconnecting the cables.
6. Disconnect the black jump lead from the negative (-) terminal of the vehicle battery remote charge terminal and the booster battery negative (-) terminal.
7. Disconnect the red jump lead from the positive (+) remote charge terminal of the vehicle and the booster battery positive (+) terminal.
8. Refit the terminal covers, trim panel and luggage compartment floor panel.

It may be necessary to reset the electric parkbrake, see page 164. See also 246.

CHARGING THE VEHICLE BATTERY



WARNING:

Batteries produce combustible gas (hydrogen) when being charged. The battery must be removed from the vehicle before charging commences.

Due to the restricted accessibility of the centrally located battery, charging of the battery should be assigned to qualified assistance.

Vehicle Battery

If the message **BATTERY NOT CHARGING** is displayed there is either a generator or battery fault. Turn off all electrical accessories, radio, climate control etc. Try to use minimum electrical load as possible such as power windows, convertible top etc. Seek qualified assistance as soon as possible.

Effects of battery disconnection

After reconnecting the battery:

- Reset the electric parkbrake; see page 164.
- Reset the electrically operated windows anti-trap function; see page 87.
- The trip computer will lose all recorded trip data and all trip functions will be reset to zero. The vehicle total odometer reading is retained.
- If the battery is disconnected for more than 72 hours the radio preset channels will need to be reset.
- Reset the clock to the correct time, see page 142.
- Recalibrate the seat memory positions; see page 139.

The engine electronic control system automatically adapts to certain characteristics of the vehicle. When the battery is disconnected, these adaptations are lost.

On reconnection, therefore, some slightly abnormal drive symptoms may occur and the vehicle may need to be driven 16 kilometers (10 miles) or more while the control system re-adapts.

When the vehicle main battery is disconnected and then reconnected, the security system immediately returns to the state that it was when the battery was disconnected.

Note: *Ensure that a remote handset is available to disarm the system when reconnecting the battery. Either press the unlock button on the transmitter, or press the START/STOP button for **convenience mode**.*

Wheels and Tires

TIRE CARE

Tire glossary

Refer to page 278 for a glossary of terms and definitions associated with tire pressures and vehicle weights.

Tire pressures



WARNING:

Improperly inflated tires can affect vehicle handling and can fail suddenly, possibly resulting in loss of vehicle control.

Caution: Never exceed the maximum pressure stated on the sidewall. Over inflation could cause the tire to fail suddenly.

In the interest of safety, reliability and fuel efficiency, check the tires, including the spare, for condition and pressure on a weekly basis and before long journeys.

Pressure checks must be carried out when the tires are cold and the vehicle has been standing in ambient local conditions for at least one hour.

Do not check tire pressures immediately after the vehicle has travelled in excess of 1.6 km (1 mile). Tire temperatures and pressures increase when running. Deflating a warm tire to the recommended pressure will result in under inflation.

If tire pressures are checked while the vehicle is inside a protected covered area, e.g. a garage, and subsequently driven in lower outdoor temperatures, tire under inflation could occur.

A slight pressure loss occurs naturally with time. If this exceeds 0.14 bar (2 lbf/in², 14 kPa) per week, have the cause investigated and rectified by a qualified assistance.

If winter tires are fitted, please refer to the winter tire pressure information on page 265.

Tire pressure label (Canada and Mexico only)

A tire recommendation label is located on the end of driver's door, giving information specific to the vehicle's wheel and tire equipment.

These pressures provide optimum ride and handling characteristics for all normal operating conditions.

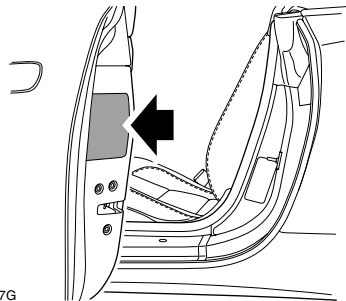

JAG0057G

Wheels and Tires

Tire pressure label/placard (USA only)

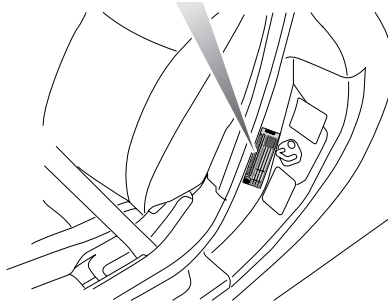
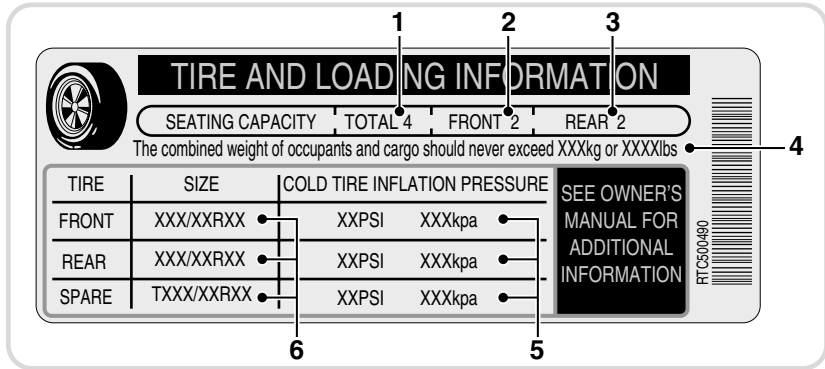

JAG0394N

A tire information label is visible on the pillar behind the driver's door (also known as the B pillar), giving information specific to the wheel and tire equipment fitted to the vehicle when it was built.

These pressures provide optimum ride and handling characteristics for all normal operating conditions.

The label contains the following information:

- The maximum number of occupants **1**, divided between the front **2** and rear **3** of the vehicle.
- The vehicle capacity weight **4**, which includes the weight of the driver, passengers and cargo.

- Cold inflation pressures for the front, rear and spare tire **5**.
- The size of the tires **6** with which the vehicle was originally equipped.

Note: The label must not be changed, even if different wheels are fitted at a later stage.

Wheels and Tires

Recommended tire pressures

The following table gives the tire pressures for all recommended tire sizes:

Tire Size	Tire Pressure	
	Front	Rear
245/45ZR18 100Z	210 k Pa (30 lb/in ²)	-
275/40ZR18 103Z	-	227.5 kPa (33 lb/in ²)
245/40ZR19 94Y	210 kPa (30 lb/in ²)	-
275/35ZR19 96Y	-	227.5 kPa (33 lb/in ²)
255/35ZR20 97Y	210 kPa (30 lb/in ²)	-
285/30ZR20 99Y	-	227.5 kPa (33 lb/in ²)
19 inch run-flat:	-	-
245/40R19 RSC 94Y	210 kPa (30 lb/in ²)	-
275/35R19 RSC 96Y	-	227.5 kPa (33 lb/in ²)
Temporary use spare wheel (front or rear)		420 kPa (60 lb/in ²)

Checking tire pressures

The following procedure should be used to check and adjust the tire pressures when cold:

1. Remove the valve cover.
2. Firmly attach a tire pressure gauge or inflator to the valve.
3. Read the tire pressure from the gauge. If required, add air to the tire.
4. If air is added to the tire, remove the gauge from the valve and re-attach it before checking that the pressure is correct. Failure to remove and re-attach the gauge could cause the gauge to show an incorrect reading.
5. If too much air is added, remove the gauge from the valve and allow air out of the tire by pressing the centre of the valve. Reconnect the gauge to the valve, and check that the air pressure is correct.
6. Refit the valve cover.

A slight natural pressure loss occurs with time. If this exceeds 14 kPa (2 lbf/in²) per week, the cause should be investigated and rectified.

Note: *It is an offence in certain countries to drive a vehicle with tires that are not inflated in accordance with the vehicle's proper use.*

Wheels and Tires

Ambient temperature pressure compensation

If the intended journey will take the vehicle into an area where the ambient local temperature is known to be lower than the journey start point, tire pressure under inflation could occur.

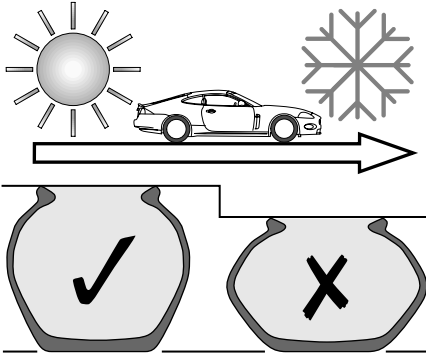

JAG0480G

A colder ambient local temperature will reduce pressure within the tire. An effect is to decrease sidewall height and to increase tire shoulder wear with the potential for tire failure. Vehicle dynamics could also be adversely affected.

In order to minimise this effect, tire pressures can be adjusted to compensate before the start of the journey. Alternatively, tire pressures can be adjusted when the area of lower ambient temperature is reached.

In this situation the vehicle must be left in the ambient local temperature for a least one hour before tire pressure is adjusted.

To compensate for colder ambient temperatures, tire pressures should be increased by 0.14 bar (2 lbf/in², 14 kPa) for each 10°C (20°F) decrease.

Note: Ensure that correct tire pressures are maintained when moving to areas of differing ambient temperature.

The Tire Pressure Monitoring system (TPMS) may issue a warning if the under inflation becomes significant. When driving through variable climatic conditions the TPMS warnings may be intermittent.

In areas of extended high ambient temperature, vehicle tires can be affected by a softening of the tire sidewall. If the vehicle is stationary for long periods, the effect is to slightly deform the tire at the point where the tire meets the standing surface. This is known as a flat spot.

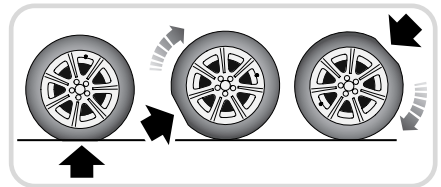
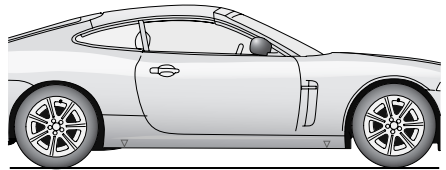

JAG0481G

This is normal tire behaviour, however, when the vehicle is subsequently driven vibration may be experienced from the flat spot. The condition will steadily improve with additional mileage.

In order to minimise this effect, tire pressures can be adjusted to compensate.

Wheels and Tires

For each 10°C (20°F) increase in temperature above 20°C (68°F), tire pressure should be increased by 14 kPa (2 lbf/in²).

Tire pressure compensation chart - high ambient temperatures

Tire Pressure Temperature Compensation	
Ambient Temperature ° C (° F)	Pressure Compensation bar (lbf/in² /kPa)
20 (68)	use placard label
30 (86)	+ 0.14 (2 / 14)
40 (104)	+ 0.28 (4 / 28)
50 (122)	+ 0.41 (6 / 41)

Wheels and Tires

Tire Markings

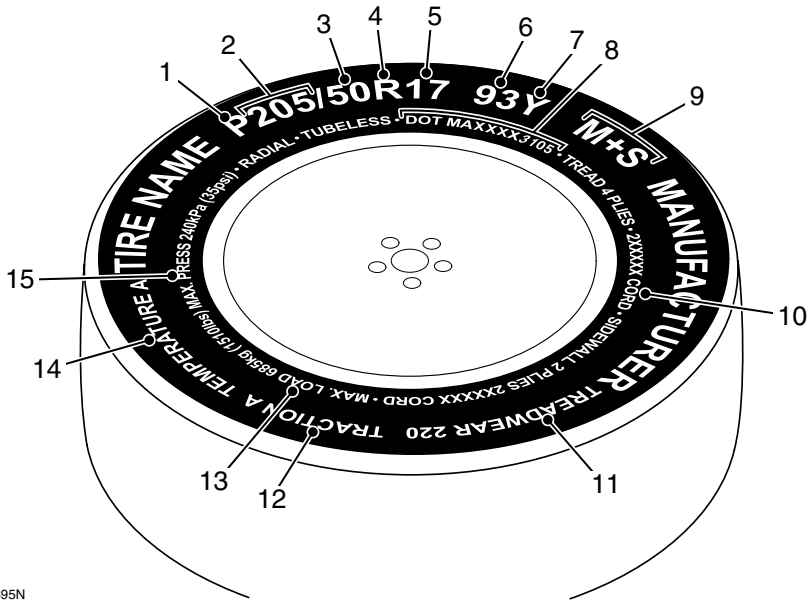

JAG0395N

P, 1

The **P** indicates the tire is for passenger vehicles.

Tire width, 2

This three-digit number gives the width in millimetres of the tire from sidewall edge to sidewall edge. In general, the larger the number, the wider the tire.

Aspect ratio, 3

This two-digit number, known as the aspect ratio, gives the tire's ratio of height to width (this is also known as the tire profile). The lower the number, the shorter the tire's sidewall.

R, 4

The **R** stands for radial. Radial ply construction of tires has been the industry standard for the past 20 years.

Wheel diameter, 5

This two-digit number is the wheel or rim diameter in inches. If you change your wheel size, you will have to purchase new tires to match the new wheel diameter.

Load index, 6

This two- or three-digit number is the tire's load index. It is a measurement of how much weight each tire can support.

Note: You may not find this information on all tires because it is not required by law.

Wheels and Tires

Speed rating, 7

The speed rating denotes the speed at which a tire is designed to be driven for extended periods of time. The ratings range from 99 mph to 186 mph. These ratings are listed in the following table.

Note: *You may not find this information on all tires because it is not required by law.*

Letter Rating	Speed Rating
Q	99 mph
R	106 mph
S	112 mph
T	118 mph
U	124 mph
H	130 mph
V	149 mph
W	168 mph
Y	186 mph*

* For tires with a maximum speed capability over 149 mph, tire manufacturers sometimes use the letters ZR. For those with a maximum speed capability over 186 mph, tire manufacturers always use the letters ZR.

U.S DOT Tire Identification Number (TIN), 8

This begins with the letters **DOT** and indicates that the tire meets all federal standards. The next two numbers or letters are the plant code where it was manufactured, and the last four numbers represent the week and year the tire was built. For example, the numbers 3197 means the 31st week of 1997. The other numbers are marketing codes used at the manufacturer's discretion. This information can be used to contact consumers if a tire defect requires a recall.

M+S and all season icon, 9

The **M+S** or **M/S** indicates that the tire has some mud and snow capability. Most radial tires have these markings.



Tires with all season icon have a level of winter performance.

Tire ply composition and materials used, 10

The number of plies indicates the number of layers of rubber-coated fabric in the tire. In general, the greater the number of plies, the more weight a tire can support. Tire manufacturers also must indicate the materials in the tire, which include steel, nylon, polyester, and others.

Wheels and Tires

Treadwear number, 11

This number indicates the tire's wear rate. The higher the treadwear number is, the longer it should take for the tread to wear down. For example, a tire graded 400 should last twice as long as a tire graded 200.

Traction letter, 12

This letter indicates a tire's ability to stop on wet pavement. A higher graded tire should allow you to stop your car on wet roads in a shorter distance than a tire with a lower grade. Traction is graded from highest to lowest as **AA**, **A**, **B**, and **C**.

Maximum load rating, 13

This number indicates the maximum load in kilograms and pounds that can be carried by the tire.

Temperature letter, 14

This letter indicates a tire's resistance to heat. The temperature grade is for a tire that is inflated properly and not overloaded. Excessive speed, underinflation or excessive loading, either separately or in combination, can cause heat build-up and possible tire failure. From highest to lowest, a tire's resistance to heat is graded as **A**, **B**, or **C**.

Maximum permissible inflation pressure, 15

This number is the greatest amount of air pressure that should ever be put in the tire under normal driving conditions.

Tire pressures during long term vehicle storage

To minimise the possibility and effects of flat spots during storage, the tires may be inflated to the maximum pressure indicated on the tire sidewall.

Note: *Before using the stored vehicle on the road again, ensure that correct tire pressures are restored.*

Wear



All tires fitted as original equipment include Tread Wear Indicators (TWI) in their tread pattern.

When the tread has worn to a remaining depth of 1.6 mm the indicators appear at the surface as bars which connect the tread pattern across the full width of the tire.

It is illegal, in certain countries, to continue to use tires after the tread has worn to less than 1.6 mm over three quarters of the width and the entire circumference of the tire.

It should be noted that the properties of many tires alter progressively with wear. In particular the wet grip and aquaplaning resistance are gradually but substantially reduced. Extra care and speed restriction should therefore be exercised on wet roads as the effective tread depth diminishes.

Wheels and Tires

Incorrect wheel alignment will accelerate tire wear. If there is wear on the inner or outer edges of the tread pattern it will be advantageous to have the cause detected by having the wheel alignment checked.

Do not interchange tires from side to side, front to rear or vice versa.

Note:

- 1. On all models the rear wheel and tire assemblies are larger than the front. These larger assemblies must never be fitted to the front of the vehicle.*
- 2. On certain models the tires may be directional type. These tires must be fitted so that when viewed from the side of the vehicle, direction of rotation arrow, on the tire wall, points in the vehicle forward direction of travel when positioned at the top of the tire.*

Damage

Caution: Do not use paraffin (kerosene), because this has a detrimental effect on rubber.

Excessive local distortion can cause the casing of a tire to fracture and may lead to premature failure. Tires should be examined especially for cracked walls, exposed cords, etc. Flints and other sharp objects must be removed from the tire tread; if left in they may work through the cover. Clean off any oil or grease contamination by using a suitable cleaner.

Tire repair

Damaged tires should be replaced with new tires fitted. They must not be repaired in view of the high performance capability of the vehicle.

Tire replacement

When replacing tires, it is preferable to fit a complete vehicle set. If either front or rear tires only need to be renewed, new tires must be fitted as axle sets.

After new tires have been fitted the wheels need to be dynamically balanced.

Do not fit tires with a different tread pattern, size or speed rating.

The installation of replacement tires with steel cord body plies in the tire sidewall may cause malfunction of the Tire Pressure Monitoring System (TPMS) and is not recommended (cord material information is moulded on the tire sidewall).

Additionally, if your vehicle was equipped with run-flat tires, replacing them with tires that are not identical to those originally fitted may cause malfunction of the TPMS, and is not recommended.

Always check your TPMS indicator after replacing one or more tires on your vehicle. See TPMS, page 267.

Tire ageing



WARNING:

Tires degrade over time, even when they are not being used. It is recommended that tires generally be replaced after six years of normal service. Heat caused by hot climates or frequent high loading conditions can accelerate the ageing process.

You should replace the spare tire when you replace the other road tires due to the ageing of the spare tire.

Wheels and Tires

USING WINTER TIRES

Winter tires are more suitable during extremes of low temperatures, snow and ice and will considerably improve the vehicle's handling during these conditions.

Do not exceed 240 km/h (150 mph) when using Jaguar approved winter tires.

Winter tires must be fitted on all four wheels.

Approved Winter tire sizes

Front: 245/45R18, Dunlop Wintersport M3 96V.

Rear: 265/40R18, Dunlop Wintersport M3 97V.

Winter tire pressures:

	Up to 240 km/h (150 mph)
Front (245)	2.0 bar (30 lbf/in ² , 207 ka)
Rear (265)	2.3 bar (33 lbf/in ² , 230 kPa)

USING SNOW CHAINS



WARNING:

Trac DSC must be switched ON when using snow chains. DSC would reduce the deep snow traction capability as it would limit wheel spin to a level below that which is required to generate maximum traction.

Caution: Do not fit snow chains to 20 inch tires.

Snow chains, of the recommended type, can only be fitted to rear wheels. They should not be used on temporary use spare wheels.

You should contact your Jaguar Dealer for details and availability of approved snow chains.

The maximum speed when using snow chains is 48 km/h (30 mph).

Remove the snow chains immediately the roads are clear of snow.

Ensure the fitting instructions supplied with the snow chains are kept in a safe place, for example, with this literature pack.

Wheels and Tires

TECHNICAL SPECIFICATIONS

Recommended tire fitment

The following chart details the tires recommended for use in USA, Canada, Mexico and the Dominican Republic:

	Tire size	Pattern
Front	245/45ZR18 100Z	Continental Sport Contact 2 Asymmetric
Rear	275/40ZR18 103Z	Continental Sport Contact 2 Asymmetric
Front	245/40ZR19 94Y	Dunlop Sport 01 Asymmetric
Rear	275/35ZR19 96Y	Dunlop Sport 01 Asymmetric
Front	255/35ZR20 97Y	Dunlop Sportmaxx Directional
Rear	285/30ZR20 99Y	Dunlop Sportmaxx Directional
19 inch Run-flat		
Front	245/40R19 RSC 94Y	Dunlop Sport 01 DSST
Rear	275/35R19 RSC 96Y	Dunlop Sport 01 DSST
Temporary use spare wheel		
Front and Rear:		
Alloy 4 x 18	T135/80 R18	Pirelli

For all other countries refer to your local Jaguar Dealer for specific tire fitment.

Wheels and Tires

TIRE PRESSURE MONITORING SYSTEM (TPMS)



WARNING:

- The TPMS is not a substitute for manually checking tire pressures. Tire pressures should be checked regularly using an accurate pressure gauge when cold. Failure to properly maintain your tire pressures could increase the risk of tire failure, with consequential loss of vehicle control and personal injury.
- The TPMS cannot register damage to a tire. Regularly check the condition of your tires, especially if the vehicle is driven off road.

Note:

1. *Non-approved accessories may interfere with the system. If this occurs, **TIRE PRESSURE SYSTEM FAULT** is displayed in the message centre.*
2. *Tires may affect the performance of the TPMS. Always replace tires in accordance with recommendations, see page 266.*

Your vehicle may be equipped with a TPMS which monitors pressure in each tire (temporary use spare tires are not fitted with sensors and are consequently not monitored).

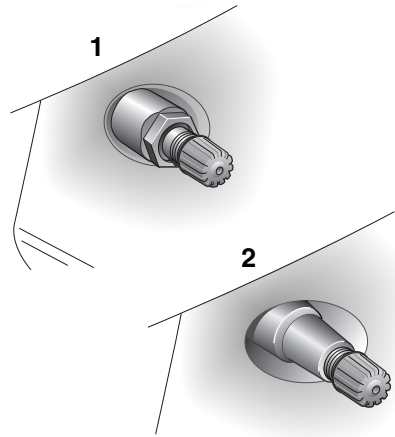

JAG0389G

Wheels fitted with a TPMS can be easily visually identified by the external metal lock nut and valve **1**. All Jaguar non-TPMS wheels have a rubber valve fitted **2**.

TPMS operation

The TPMS monitors the pressure of the tires via sensors located in each wheel and a receiver located within the vehicle. Communication between sensor and receiver is via Radio Frequency (RF) signals.



The tire pressure warning comprises a yellow warning telltale within the instrument cluster and an associated message within the message centre.

Wheels and Tires

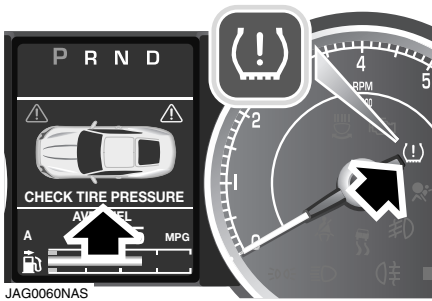

Each tire, including the spare (if provided), should be checked monthly when cold and inflated to the inflation pressure recommended by the vehicle manufacturer on the vehicle placard or tire inflation pressure label. (If your vehicle has tires of a different size than the size indicated on the vehicle placard or tire inflation pressure label, you should determine the proper tire inflation pressure for those tires).

As an added safety feature, your vehicle has been equipped with a tire pressure monitoring system (TPMS) that illuminates a low tire pressure telltale when one or more of your tires is significantly under-inflated.

Accordingly, when the low tire pressure telltale illuminates, you should stop and check your tires as soon as possible, and inflate them to the proper pressure. Driving on a significantly under-inflated tire causes the tire to overheat and can lead to tire failure. Under-inflation also reduces fuel efficiency and tire tread life, and may affect the vehicle's handling and stopping ability.

Please note that the TPMS is not a substitute for proper tire maintenance, and it is the driver's responsibility to maintain correct tire pressure, even if under-inflation has not reached the level to trigger illumination of the TPMS low tire pressure telltale.

The TPMS may issue a warning if the under inflation becomes significant. When driving through variable climatic conditions the TPMS warnings may be intermittent.

Caution: When inflating tires, care should be taken to avoid bending or damage to the TPMS valves. Always ensure correct alignment of the inflation head to the valve stem.

Your vehicle has also been equipped with a TPMS malfunction indicator to indicate when the system is not operating properly.

The TPMS malfunction indicator is combined with the low tire pressure telltale. When the system detects a malfunction, the telltale will flash for approximately one minute and then remain continuously illuminated. This sequence will continue upon subsequent vehicle start-ups as long as the malfunction exists

When the malfunction indicator is illuminated, the system may not be able to detect or signal low tire pressure as intended. TPMS malfunctions may occur for a variety of reasons, including the installation of replacement or alternate tires or wheels on the vehicle that prevent the TPMS from functioning properly.

Wheels and Tires

Always check the TPMS malfunction telltale after replacing one or more tires or wheels on your vehicle to ensure that the replacement or alternate tires and wheels allow the TPMS to continue to function properly.

A supplementary text message will accompany the system indicator and will display **TIRE PRESSURE SYSTEM FAULT**.

Temporary use spare wheel and tire change

Should it be necessary to change a wheel and tire with the temporary use spare, then the system will automatically recognise the change in wheel positions. Then after approximately ten minutes of driving above 25 km/h (18 mph), a text message **TIRE NOT MONITORED** will be displayed accompanied by illumination of the warning telltale and the corresponding block in the vehicle graphic.

The warning telltale will initially flash and will subsequently revert to continuous illumination. Extended use of the temporary use spare wheel will produce an additional text message **TIRE PRESSURE SYSTEM FAULT**.

The TPMS display sequence will be activated at every ignition cycle until the temporary use spare wheel is replaced by a fully operational full size wheel and tire assembly.

Always replace the temporary use spare wheel before having TPMS faults investigated. The fault may well be rectified with the fitment of a fully operational full size running tire in lieu of the temporary use wheel and tire assembly.

If a tire needs to be changed

It is recommended that you should always have your tires serviced by a Jaguar Dealer.

If a TPMS is fitted, each wheel and tire assembly, with the exception of a temporary use spare is equipped with a tire pressure sensor connected to the tire valve stem.

In order to avoid damage to the sensor the tires must be removed and refitted to the road wheel in a specific manner. Care must be taken to avoid contact between the bead of the tire and the sensor during removal and refitting of the tire, otherwise the sensor may become damaged and or inoperable.

Caution: Valve stem seal, washer, nut, valve core and cap should be replaced at every tire change. Valve stem seal, washer and nut must be replaced if valve retention nut is loosened. Sensor units and nuts must be refitted using correct torques and associated torque profile. Damage to the vehicle may result if these precautions are not taken.

Sensors can be removed from the wheel by the unscrewing of the valve retention nut.

Replacement sensor fitment procedure

A replacement sensor must be fitted to a running wheel in order to be recognised by the system. Recognition only occurs when the vehicle is driven above 25 km/h (18 mph) for approximately ten minutes.

Wheels and Tires

Should the TPMS warning for any wheel not clear, even after ensuring correct inflation pressures and driving for more than ten minutes above 25 km/h (18 mph), contact your Jaguar Dealer.

TPMS information messages

Message	Warning Light	Priority Indicator	Meaning
CHECK TIRE PRESSURE (Graphic indication displays which tire is under inflated.)	TPMS	Amber	You should as soon as possible stop, check your tire and inflate them to the recommended pressure.
CHECK ALL TIRE PRESSURES	TPMS	Amber	One or more tire is significantly under-inflated. You stop as soon as possible, check your tires and inflate them to the recommended pressure. This message may be displayed when the vehicle is learning a new sensor to vehicle and one or more tires has low pressure.
TIRE PRESSURE SYSTEM FAULT	TPMS	Amber	<ol style="list-style-type: none">1. You have fitted wheels and tires which do not have TPMS sensors. You should as soon as possible have TPMS sensors fitted to wheels and tires.2. TPMS sensors have become defective, an unapproved accessory is interfering with the TPMS or a general fault has been detected in the TPMS. Contact a Jaguar Dealer as soon as possible.

Wheels and Tires

TPMS information messages

Message	Warning Light	Priority Indicator	Meaning
TIRE NOT MONITORED (Graphic indication displays which tire is not monitored.)	TPMS	Amber	<ol style="list-style-type: none">1. You have a temporary use spare wheel fitted at the corresponding position. You should limit your vehicle speed to 80 km/h (50 mph) and as soon as possible replace the temporary use spare wheel with a correctly inflated full size tire.2. The TPMS sensor, at the corresponding position, has become defective, an unapproved accessory is interfering with the TPMS or you have fitted a wheel and tire which does not have a sensor. Contact a Jaguar Dealer as soon as possible.

Wheels and Tires

WHEEL CHANGING



WARNING:

- Always ensure replacement tires have the correct rating and specifications (e.g. load index, size, speed rating) for your vehicle.
- When using tires other than those recommended by Jaguar, do not exceed the speed capacity recommended by the manufacturer.
- Wheels are extremely heavy. Take care when lifting and particularly when removing and replacing a wheel in its storage position in the luggage compartment.

If a wheel change is required, pull off the road completely. Park on ground which is as level and solid as possible. Ensure that the vehicle is clear of any objects that will obstruct the safe removal of the wheel. Switch on hazard warning lights and, where legally required, display the warning triangle.

Regular maintenance of tires contributes not only to safety, but to the designed function of the vehicle. Road-holding, steering and braking are especially vulnerable to incorrectly pressurised, badly fitted or worn tires.

Tires of the correct size and type, but of different make can vary in characteristics. It is therefore recommended that Jaguar approved tires are fitted to all wheels.

Caution: Ultra high performance tires.

This vehicle is equipped with an Ultra High Performance (UHP) tire and wheel combination designed to give maximum dry road performance with consideration for aquaplaning resistance. UHP tires have performance enhancing soft rubber tread compound. If driven aggressively they may suffer rapid tread wear and a shorter life than can be expected from other tire types. This wheel and tire combination is more susceptible to damage from road hazards.

Do not use this combination for driving on snow or ice. High performance tires must be replaced with winter tires when weather conditions dictate.

Temporary use spare wheel

IMPORTANT - USE OF SPARE TIRE

Observe the following warnings before using the wheel:



WARNING:

- Please note temporary use spare wheel warning label. Adhere to instructions on the label. Failure to comply can be dangerous.
- When a temporary use spare wheel is fitted, drive with caution and replace with the specified wheel and tire as soon as possible.
- Do not fit more than one temporary use spare wheel and tire assembly at one time.
- The temporary use spare wheel must be inflated to 4.2 bar (60 lb/in², 420 kPa) and cannot be repaired.

Wheels and Tires

- **Temporary use spare wheel, maximum speed is 80 km/h (50 mph).**
- **If the vehicle is fitted with Tire Pressure Monitoring System (TPMS) refer to page 267.**
- **DSC must be ON when the temporary use spare wheel is in use.**

Run-flat tires



WARNING:

If a run-flat is deflated maximum vehicle speed must not exceed 80 km/h (50 mph).



Run-flat tires can be identified by the lettering **RSC** on the sidewall. The tire construction utilises a specially reinforced sidewall which allows the vehicle to be driven at restricted speeds even when the tire is depressurised. Run-flat tires can only be fitted to special rims constructed for run-flat tire use.

A tire pressure monitoring system is mandatory when the vehicle is fitted with run-flat tires, see page 267.

If the tire in a deflated the vehicle should be driven with caution, as handling characteristics will be different compared to a fully inflated tire.

If the vehicle is fully laden with passengers and luggage, the maximum distance that can be completed on a fully deflated tire is approximately 80 kilometres (50 miles).

Stop immediately if the tire construction begins to break down, or if the tire dislodges from the wheel rim. Typically, this will be accompanied with excessive vibration.

A tire driven in a deflated condition it must be replaced.

Vehicles fitted with run-flat tires are not fitted with a spare wheel or jacking equipment. Therefore, run-flat tires should be replaced with the same type of tire.

Wheels and Tires

Locking wheel nuts

Vehicles may be equipped with a locking wheel nut on each wheel. These are similar to standard wheel nuts, and can only be removed using the special adaptor provided with the jacking equipment.

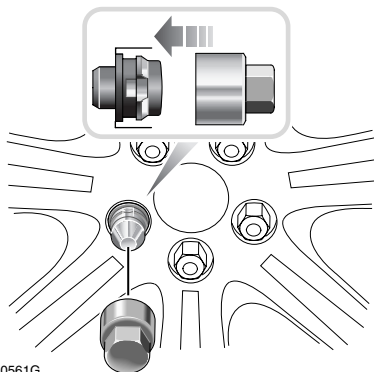

1. Insert the adaptor firmly onto the locking wheel nut.
2. Using the wheel brace, unscrew the wheel nut and adaptor.
3. Return the locking wheel nut adaptor to the correct storage position.

Note: A code number is stamped on the side of the locking nut. Ensure the number is recorded on the Security Card supplied with the literature pack. Quote this number if a replacement is required. Do not keep the Security Card in the vehicle.

Spare wheel location

The spare wheel and jacking equipment are stored under the luggage compartment floor panel.

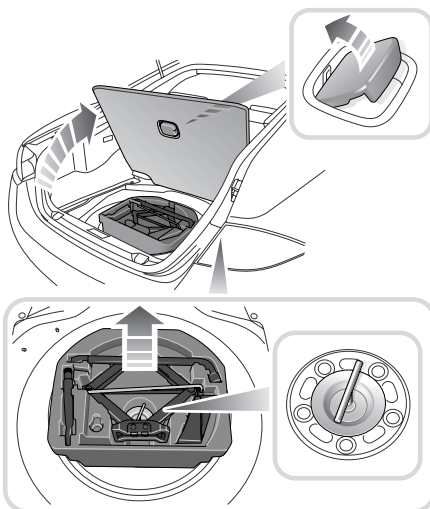

To remove the spare wheel, remove the luggage compartment floor panel and the tray containing the jacking equipment. Unscrew the spare wheel retaining Tee bolt and remove the spare wheel.

Remove the jack and wheel nut wrench from the stowage tray.

Note: Examine the jack occasionally and clean and grease the threads to ensure it is always ready for an emergency.

Wheels and Tires

Wheel changing procedure



WARNING:

- Before attempting to lift the vehicle with the jack, chock the wheel diagonally opposite to the wheel being replaced to prevent the vehicle from rolling when jacked up. A wheel chock is supplied with the jacking equipment for this purpose.
- Never work under the vehicle using only the jack as a support, always use axle stands or suitable supports under the jacking points.

Note: When one rear wheel is lifted off the ground the selection **P** (Park) position will not prevent the vehicle from moving and possibly slipping off the jack as the parkbrake only operates on the rear wheels.

1. Ensure that all passengers are in a safe place, clear of the vehicle.
2. Apply the parkbrake and select gear position **P** (Park).
3. Ensure that the jack is placed on firm and level ground.

Observe the instructions printed on the jack.

Use the jack only for lifting the vehicle during wheel changing and only use the jack which is stored in the vehicle.

Before raising the vehicle slacken but do not remove the wheel nuts.

Do not start or run the engine while the vehicle is supported only by a jack.

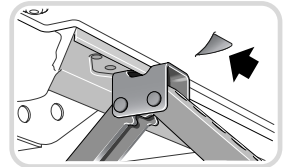
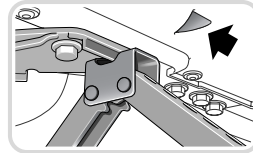
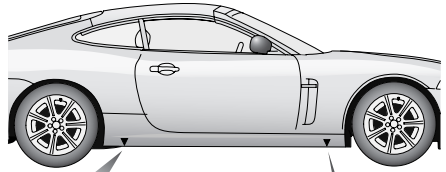

JAG0387G

There are four jacking points on the underside of the floor. Two indented, triangular indicators are provided on each sill cover. These indicate the location for the jack.

The simplest way to correctly locate the jacking point is to feel along the sill panel to the triangular indentation and then fit the jack to the body, not to the sill panel.

Wheels and Tires

Raising the vehicle



WARNING:

- Do not attempt to lift the vehicle unless the jack head is fully engaged in the jacking point.
- Ensure that the parkbrake is applied.

Caution: Ensure before raising the vehicle that the jack is correctly positioned to avoid any damage to the vehicle sills or sill panels.

Carefully raise the vehicle by turning the jack handle. Stop jacking the vehicle when the tire just clears the ground. Minimum tire lift gives maximum vehicle stability.

Remove the wheel nuts and the wheel.

To remove the centre badge use the plastic tipped end of the wheel nut wrench handle, push the centre badge from its housing from the inside of the wheel.

Push the centre badge into the replacement wheel. If the temporary use spare wheel is to be fitted, keep the centre badge safely and fit it to the repaired full size wheel when it has been refitted.

Fit the spare wheel and loosely secure with the wheel nuts.

Using the wheel nut wrench, lightly tighten the wheel nuts alternately using the sequence shown in the illustration.

Tightening the wheel nuts

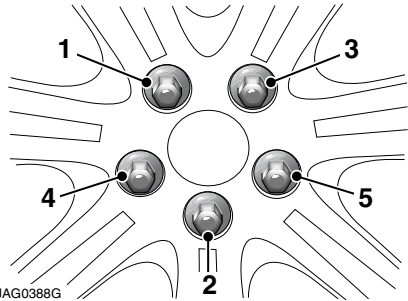

Lower the jack and tighten the wheel nuts alternately. Do not over tighten by using foot pressure or extension bars on the wheel nut wrench.

At the earliest opportunity have the wheel nuts tightened with a torque wrench to 125 Nm (92 lb.ft).

This torque must not be exceeded.

Stowing the equipment

Place the storage tray with the jack and wrench in the wheel well.

Reposition the luggage compartment floor panel.

Place the removed road wheel in the luggage compartment. The full size road wheel will not be able to be completely stowed in the wheel well.

Caution: Convertible only. The luggage separator will required to be removed before stowing the wheel in the luggage compartment, see page 151.

Wheels and Tires

UNITED STATES DEPARTMENT OF TRANSPORTATION/ UNIFORM TIRE QUALITY GRADES

The following information relates to the tire grading system developed by the National Highway Traffic Safety Administration which will grade tires by tread wear, traction and temperature performance.

Tread wear

The tread wear grade is a comparative rating based on the wear rate of the tire when tested under controlled conditions on a specified government test course. For example, a tire graded 150 would wear one and a half (1.5) times as well on the government course as a tire graded 100.

The relative performance of tires depends upon the actual conditions of their use, however, and may depart significantly from the norm due to variations in driving habits, service practices and differences in road characteristics and climate.

Traction

The traction grades, from the highest to the lowest are **AA**, **A**, **B** and **C**. The grades represent the tire's ability to stop on wet pavement as measured under controlled conditions on specified government test surfaces of asphalt and concrete. A tire marked **C** may have poor traction performance.



WARNING:

The traction grade assigned to this tire is based on straight-ahead braking traction tests and does not include cornering (turning) traction tests and does not include acceleration, cornering, hydroplaning, or peak traction characteristics.

Temperature – A, B, C

The temperature grades are **A** (the highest), **B** and **C** representing the tire's resistance to the generation of heat and its ability to dissipate heat when tested under controlled conditions on a specified indoor laboratory test wheel.

Sustained high temperature can cause the material of the tire to degenerate and reduce tire life, and excessive temperature can lead to sudden tire failure.

The grade **C** corresponds to a level of performance which all passenger car tires must meet under the Federal Motor Vehicle Safety Standard No. 109.

Grades **B** and **A** represent higher levels of performance on the laboratory test wheel than the minimum required by law.



WARNING:

The temperature grade for this tire is established for a tire that is properly inflated and not over loaded. Excessive speed, under-inflation or excessive loading, either separately or in combination, can cause heat build-up and possible tire failure.

Wheels and Tires

TIRE GLOSSARY

Cold tire pressure:

Pressure in a tire that has been driven for less than one mile or has been standing for three hours or more.

Maximum inflation pressure:

Maximum air pressure, to which a cold tire may be inflated, this figure (in kPa and psi) is moulded onto the sidewall of a tire.

Curb weight:

The weight of a motor vehicle with standard equipment including the maximum capacity of fuel, oil, coolant and if so equipped, air conditioning and additional weight optional engine.

Accessory weight:

The combined weight (in excess of those standard items which may be replaced) of automatic transmission, power steering, power brakes, power windows, power seats, radio and heater, to the extent that these items are available as factory-installed equipment (whether installed or not).

Production options weight:

The combined weight of those installed production options weighing over 1.4 kg (3 lb) in excess of those standard items which they replace, not previously considered in curb weight or accessory weight, including heavy duty brakes, ride levellers, roof rack, heavy duty battery and special trim.

Vehicle capacity weight:

The rated cargo and luggage load plus 68.0 kg (150.0 lb) times the vehicle's designated seating capacity.

Maximum loaded vehicle weight:

This is the sum of:

- Curb weight.
- Accessory weight.
- Vehicle capacity weight.
- Production options weight.

Rim:

A metal support for a tire or a tire and tube assembly upon which the tire beads are seated.

Bead:

The part of the tire that is made of steel wires, wrapped or reinforced by ply cords and that is shaped to fit the rim.

Wheels and Tires

PRODUCTION OPTIONS WEIGHTS

(USA only)

This table lists the production options weights. To calculate the curbweight of your vehicle, add the weight of all production options, including optional alloy wheels and spare wheel, to the basic curbweight for your vehicle.

Note: *The table only lists optional equipment that weigh more than 3.0 lb (1.4 kg).*



WARNING:

Do not exceed the weight limits specified on the TIRE LOADING INFORMATION label (see page 257).

To calculate the cargo and luggage load capacity of your vehicle, refer to page 280.

	Weight	
	lb	kg
Curb weight, no options fitted		
See Technical Specification Weight Tables pages 283 and 284.		
Production options		
Jaguar Premium Surround Sound System	13.23	6.0
Sirius Satellite Radio	2.87	1.3
Navigation	4.9	2.2
16 way luxury sport seats	7.72	3.5
Adaptive Front Lighting System	3.31	1.5
Wheels and tires		
18 inch wheels (Venus)	0	0
19 inch wheels (Carelia)	16.54	7.5
20 inch wheels (Senta), supercharged available	18.96	8.6
20 inch wheels (Senta), normally aspirated, if available	26.46	12.0
19 inch Run-flat tires (Sabre) deletes Temporary use spare wheel, supercharged.	- 4.0	- 8.82
19 inch Run-flat tires (Sabre) deletes Temporary use spare wheel, normally aspirated.	- 5.51	- 2.5

Note:

*The weights listed under **Wheels and tires** give the increase in weight over a standard set of four wheels: the figure only needs to be added to the curbweight once. The **Spare wheel and tire** weight must also be added, where applicable.*

Wheels and Tires

Steps for determining correct load limit



WARNING:

Do not exceed the vehicle capacity weight (the total weight of driver, passengers and cargo) given on the tire information label (see page 257).

1. Locate the statement, The combined weight of occupants and cargo should never exceed XXXX kg or XXXX lb on your vehicle's placard (see page 257).
2. Determine the combined weight of the driver and passengers that will be riding in your vehicle.
3. Subtract the combined weight of the driver and passengers from XXXX kg or XXXX lb (weight given on placard).
4. The resulting figure equals the available amount of cargo and luggage load capacity. For example, if the XXXX amount equals 1400 lb, and there will be five 150 lb passengers in your vehicle, the amount of available cargo and luggage load capacity is 650 lb:
 $1400 - 750 (5 \times 150) = 650 \text{ lb}$.
5. Determine the combined weight of luggage and cargo being loaded on the vehicle. That weight may not safely exceed the available cargo and luggage load capacity calculated in Step 4.
6. If your vehicle will be towing a trailer, load from your trailer will be transferred to your vehicle. Consult this manual to determine how this reduces the available cargo and luggage load capacity of your vehicle.

The number and weight of passengers will affect the cargo and luggage load capacity. In the example above, the cargo and luggage load capacity is 650 lb. However, if fewer passengers ride in the vehicle, the luggage load capacity will increase. If this vehicle carries three 150 lb passengers, the cargo and luggage load capacity will increase to 950 lb:
 $(3 \times 150 = 450 \text{ lb, and } 1400 - 450 = 950 \text{ lb})$.

If the passengers weigh more, the cargo and luggage load capacity will decrease.



WARNING:

- **The weight of accessories must also be subtracted from the available cargo and luggage load capacity. If you are unsure of the weight of any accessories fitted to your vehicle, contact your Jaguar Dealer.**
- **Overloading the vehicle will have an adverse affect on braking and handling characteristics, which could compromise your safety. Overloading a vehicle may also cause tire damage or failure. Never overload your vehicle.**
- **TOWING: The XK has not been designed as a towing vehicle and Jaguar Cars does not manufacture a tow bar for the vehicle.**

Vehicle Identification

VEHICLE IDENTIFICATION NUMBER (VIN)

It is essential that the Vehicle Identification Number (VIN) is quoted in all correspondence and when ordering replacement parts.

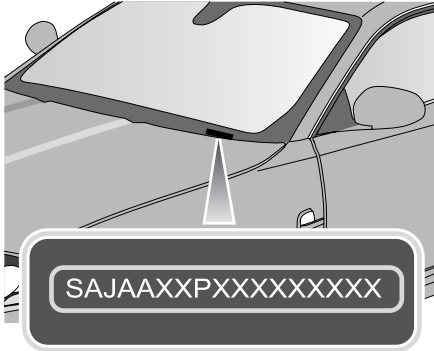

JAG0396G

The number is visible from outside the vehicle, on a plate in the lower left-hand edge of the windshield.

VEHICLE CERTIFICATION LABEL

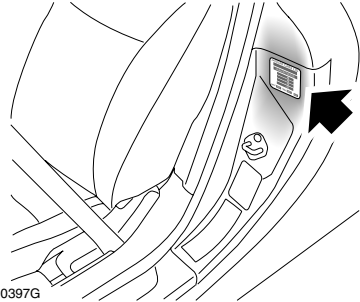

JAG0397G

Vehicles have the Certification Label adhered to the left-hand door rear post. Vehicle weights, paint code, manufacture date and the VIN are shown on this plate.

ENGINE NUMBER

The number is located on the rear left-hand side of the engine below the rectangular block.

TRANSMISSION NUMBER

The number is etched on a plinth on the side of the transmission casing.

Technical Specifications

ENGINE SPECIFICATIONS

Engine 4.2 litre V8

Capacity	4196 cm ³ (255 inch ³)	Stroke	90.3 mm (3.555 inch)
Bore	86.0 mm (3.385 inch)	Compression ratio	11.0:1 (9.1:1 supercharged)

DIMENSIONS

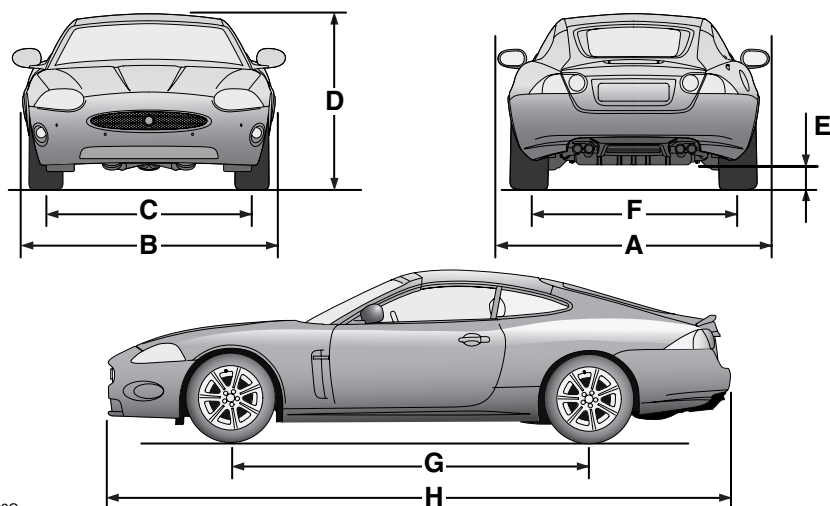

JAG0398G

A	Overall width, mirrors extended	2070 mm	81.5 in.
B	Overall width, mirrors folded	1892 mm	74.5 in.
B	Overall width, mirrors folded, rear arch extensions fitted	1912 mm	75.3 in.
C	Track: Front (maximum)	1560 mm	61.0 in.
D	Overall height at gross vehicle weight (nominal) - Coupe	1287mm	50.6 in.
D	Overall height at gross vehicle weight (nominal) - Convertible	1294 mm	51.0 in.
E	Minimum ground clearance (at gross vehicle weight)	100 mm	4.0 in.
F	Track: Rear (maximum)	1608 mm	63.3 in.
G	Wheelbase	2752 mm	108 in.
H	Overall length	4791 mm	187 in.
	Turning circle (curb to curb)	10.97 m	36.0 ft.

Technical Specifications

WEIGHTS (AVERAGE/APPROXIMATE)

V8 4.2 litre normally aspirated engine

	Coupe		Convertible	
	kg	lb	kg	lb
Curb weight (no options fitted)	1665	3671	1705	3759
Front axle Curb weight	887	1956	888	1958
Rear axle Curb weight	778	1715	817	1801
Gross Vehicle Weight (G.V.W.)	2035	4486	2075	4575
Gross front axle weight	1015	2238	1020	2249
Gross rear axle weight	1090	2403	1125	2480
Maximum recommended luggage compartment load with passenger and driver	28	62	28	62

Note: Loads greater than 28 kg (62 lb) may be carried in the luggage compartment provided the maximum technically permissible axle weights shown on the vehicle identification plate are not exceeded and the tires are inflated to the normal pressures.

Technical Specifications

V8 4.2 litre supercharged engine

	Coupe		Convertible	
	kg	lb	kg	lb
Curb weight (no options fitted)	1730	3814	1780	3924
Front axle Curb weight	935	2061	943	2079
Rear axle Curb weight	795	1753	837	1845
Gross Vehicle Weight (G.V.W.)	2080	4586	2120	4674
Gross front axle weight	1050	2315	1050	2315
Gross rear axle weight	1095	2414	1130	2491
Maximum recommended luggage compartment load with passenger and driver	28	62	28	62

Note: Loads greater than 28 kg (62 lb) may be carried in the luggage compartment provided the maximum technically permissible axle weights shown on the vehicle identification plate are not exceeded and the tires are inflated to the normal pressures.

Technical Specifications

CAPACITIES

V8 4.2 litre normally aspirated engine		
	Litres	Pints
Engine oil, including oil filter.	7.0	14.8
Cooling system, including reservoir and climate control.	10.4	22.0
Windshield and headlamp washer reservoir:	6.3	13.3

V8 4.2 litre supercharged engine		
	Litres	Pints
Engine oil, including oil filter.	7.0	14.8
Cooling system, including reservoir and climate control.	10.0	21.1
Windshield and headlamp washer reservoir:	6.6	14.0

Fuel capacity

Total tank capacity	71.1 litres (18.8 Gallons)
Fill capacity (when the fuel gauge indicates empty)	65.5 litres (17.2 Gallons)
Reserve capacity (when the fuel gauge indicates empty)	6.0 litres (1.6 Gallons)

Type Approvals

SMART KEY REMOTE CONTROL RADIO FREQUENCY

The radio frequency remote system operates on a frequency subject to USA Federal Communications Commission (FCC) rules.

The device complies with Part 15 of the FCC rules and RSS-210 of the Industry Canada. Operation is subject to the two following conditions:

- The device may not cause harmful interference.
- This device must accept any interference received, including interference that may cause undesired operation.

The key transmitter radio frequency approval numbers for the USA and Canada are shown below:

USA - CWTWB1U243

Canada - 1788A-1U243

Note: *The manufacturer is not responsible for any radio interference or TV interference caused by unauthorised modifications to this equipment. Changes or modifications not expressly approved by the party responsible for compliance could void the user's authority to operate the equipment.*

Caution: The Jaguar Smart Key may suffer interference from other legal users of this radio frequency band, such as radio amateurs, medical equipment, remote controls or alarm systems. To lock or unlock the vehicle in such a situation, either use a key or operate the key transmitter as close to the security antenna on the front screen as possible.

DECLARATION OF CONFORMITY FOR THE TELEPHONE SYSTEM

Export controls

This product contains commodities, technology or software exported from the United States in accordance with the Export Administration regulations. Diversion contrary to U.S. or Canadian law is prohibited.

FCC/Industry Canada Notice

This device complies with Part 15 of the FCC rules. Operation is subject to the following two conditions: (1) this device may not cause harmful interference, and (2) this device must accept any interference received, including interference that may cause undesired operation.

FCC ID: AZ489FT7024

Canada IC: 109U-89FT7024

Changes or modifications not expressly approved by the party responsible for compliance could void the user's authority to operate the equipment.

Note: *This equipment has been tested and found to comply with the limits for a Class B digital device, pursuant to Part 15 of the FCC Rules. These limits are designed to provide reasonable protection against harmful interference in a residential installation.*

Type Approvals

This equipment generates, uses and can radiate radio frequency energy and, if not installed and used in accordance with the instructions, may cause harmful interference to radio communications. However, there is no guarantee that interference will not occur in a particular installation.

If this equipment does cause harmful interference to radio or television reception, which can be determined by turning the equipment off and on, the user is encouraged to try to correct the interference by one or more of the following measures:

- *Reorient or relocate the receiving antenna.*
- *Increase the separation between the equipment and receiver.*
- *Connect the equipment into an outlet on a circuit different from that to which the receiver is connected.*
- *Consult the dealer or an experienced radio/TV technician for help.*

DOLBY LICENSING



Dolby Pro Logic Surround and the double-D are registered trademark

of Dolby Laboratories. Manufacturing rights for Dolby Pro Logic Surround System are licensed from Dolby Laboratories Licensing Corporation.

TIRE PRESSURE MONITORING SYSTEM (TPMS)

The TPMS devices comply with part 15 of the FCC Rules and RSS-210. Operation is subject to the following two conditions: (1) This device may not cause interference, and (2) this device must accept interference received, including interference that may cause undesired operation.

Note: *Changes or modifications not expressly approved by the manufacture could void the users' authority to operate the equipment.*

The TPMS radio frequency approval numbers for the USA and Canada are shown below:

USA FCC ID: KR5S120123,
TX KR55WK47594, RX 5WK4887.

Canada IC: 267T-S120123,
267T-5WK47594, CAN2671032336A.

Index

Accessory socket	142	Automatic transmission	157
Active headlamps	69	gear selector positions	157
Adaptive cruise control	172	gearshift interlock	157
forward alert	177	Jaguar sequential shift mode gear selection	159
Adjusting the time	142	kickdown	158
Advanced restraint technology system (ARTS)	95	limp-home mode	161
components	98	system fault display	161
Air bags		Battery	
disposal	101	charging	245
front	99	disconnection effects	246
labels	99	maintenance	243
occupancy sensing	96	using booster cables	243
side	101	warning signs	242
warning lamp	101	Bi-Xenon headlamps	69
Air conditioning	137	Booster seats	108
Alarms and audible signals	49	Brake fluid check	240
Anti-lock braking system (ABS)	162	Brakes	162
Audible warnings and indicators	116	ABS	162
Audio system	182	emergency brake assist	163
auto memory	189	Bulbs	
automatic volume control	190	changing	77
band switching	186	Catalytic converters	54
care	183	Checking and top up	
CD operation	196	brake fluid	240
compact disc player	194	coolant level	238
Dolby licensing	287	engine oil	237
load a CD	195	power steering fluid	241
MP3 CDs	198	windshield/headlamp washer	239
premium sound	190	Child safety	103
preset stations	190	booster seats	108
programme type (PTY)	188	child seats	103
radio text	186	choosing a child seat	104
RDS	192	fitting the child seat	105
recordable CDs	197	infant safety	104
seek tuning	189	LATCH seats	106
settings	187	restraint check list	106
unload a CD	195	top tether anchorages	106
use	185	Climate control	132
Autolamps	72	air distribution	134
windshield wiper detection	72	Clock adjustment	142
Automatic speed limiter	180		

Index

Computer active technology system (CATS)	166	Exterior lighting	
Convenience mode	42	daylight running lamps	73
Convertible top	147	exit delay	72
care and cleaning	227	touring adjustment	76
closing	152	Exterior mirrors	89
luggage separator	150	Facia and controls	109
deploy	151	Fire extinguisher	222
install	152	fitting	222
normal stowage	150	maintenance	222
remove	151	First aid kit	222
manual re-set	148	Floor mat retention	231
opening	147	Forward alert	177
winter conditions	150, 228	Front seat heaters	61
Cruise control	169	Fuel and refuelling	52
information messages	171	refuelling	52
Dimmer switch	140	system fault display	53
Driving after a collision	223	Fuel capacity	285
Driving hints	56	Fuel requirements	
running-in	56	gasoline engines	53
Driving position	60	Fuses	247
Dynamic stability control	165	changing	247
switching off	166	checking	247
switching on	166	fuse box locations	248
Electric park brake	164	specification chart	252
Electrical accessories	31	Garage door transceiver	143
Emergency brake assist	163	before programming	144
Engine		information and assistance	146
coolant check	238	programming the vehicle	144
keyless start	50	Gear change	157
oil check	237	General driving information	
oil consumption	237	engine oil consumption	56
rolling re-start	50	running-in	56
starting	50	Ground points	32
starting and stopping	50	Hazard warning	76
stationary vehicle	158	Headlamp powerwash	68
stopping	50	Health and safety	30
Engine compartment	235	Heated seats	61
Engine number	281	Hood release	234
Engine oil	237	Horn	63
Environmental information	232	Identification numbers	
Event data recording	32	vehicle identification number	281
		Inertia switch	223

Index

Instruments	111	Lighting	69
dimmer switch	140	auto headlamp levelling	76
fuel gauge	111	autolamps	72
message centre	111	battery saver	74
speedometer	111	bulb replacement	
tachometer	111	cornering lamp	82
Interior features		front direction indicator	80
centre console	141	front sidelamp	80
cigar lighter and ashtray	140	headlamp assembly	77
glove box	142	license plate lamp	83
accessory socket	142	main and dipped beam	81
sunvisors		rear lamp unit	84
vanity mirrors	141	side marker	79
Interior lighting	73	side repeater	83
Interlock	157	cabin	73
Jaguar parts and accessories	31	direction indicators	74
Jump leads	243	entry and exit	73
Key transmitter radio frequency	286	front fog lamps	75
Keyless entry	41	glove compartment	74
Keyless starting	50	hazard warning	76
Keys		headlamps	71
key transmitter	34	luggage compartment	74
Keys and remote controls	34	reading	73
information messages	38	rear fog lamp	75
Smart Key	35	sidelamps	71
Kickdown	158	Locking the vehicle	
		drive-away locking	43
		external locks	42
		internal locks	43
		Locking wheel nuts	274
		Luggage compartment	43, 156
		emergency release	44
		luggage cover	156
		Luggage separator	
		deploy	151
		install	152
		normal stowage	150
		remove	151
		Maintenance	232
		regular servicing	232

Index

Memory function	139	Running-in	56
passenger seat position	139	brakes	56
recalling memorised position	139	engine	56
setting driving position	139	final drive unit.	56
Message centre.	118	Satellite radio	199
warning messages	118	home screen	200
Mirrors	89	options menu	204
heating.	89	preset radio stations	200
interior rear view mirror	90	recalling presets.	201
Occupant protection	91	receiving satellite broadcasts	199
components	98	song seek.	201
Oil consumption	56	subscription to SIRIUS.	208
Oil level	237	Seat belts	
On-board event data.	32	beltminder	113
Panic alarm	49	during pregnancy.	94
Parkbrake	164	fastening	91
Parking aid	167	reminder.	93
cleaning.	168	tension sensor	92
system fault.	168	Seat heaters.	61
touch-screen setting	167	Seats	57
Power steering		adjustment	57
fluid check.	241	driving position.	60
Powerwash	68	head restraints	61
Production option weights	279	heater.	61
Protect the environment	232	seatback tilt	59
Puncture		Security	
wheel changing	275	alarms and audible signals	49
Radio		immobiliser.	51
display panel.	185	panic alarm	49
Radio reception.	182	Service data recording.	32
Rain sensitive wiper control	66	Smart Key	34
Rear impact protection	102	battery renewal	40
Rear window operation	88	convenience mode.	42
Reception quality	182	irregular operation	37
Recommended engine oil	238	Snow chains.	265
Regular servicing.	232	Spare wheel	272
Remote headlight convenience.	49	Spare wheel location	274
Reporting safety defects.	33	Speed control	169
Reservoir and dipstick locations		Steering wheel	62
normally aspirated engine.	235, 236	adjusting	62
Rollover protection system	102	audio controls	64
Run-flat tires	273	cruise controls	64
		Sun visors	141

Index

Technical data		
engine number	281	
Technical specifications		
capacities	285	
dimensions	282	
engine	282	
weights	283	
Telephone		
answer options	214	
automatic answering	214	
bluetooth description	210	
call continuity	220	
call volume	210	
caller announce	214	
changing a phone number	217	
directory capacity	217	
directory, auto download	215	
do not disturb option	221	
ending a call	217	
erase the telephone directory	216	
handsfree, ending a call	220	
handsfree, making a call	220	
last 10 options	219	
magnify keyboard	221	
making a call	217	
name search	218	
options	215	
pairing and docking	211	
pairing other phones	213	
receiving a call	218	
retrieving voice mail	214	
ringtones	215	
setting up your phone for use	211	
settings menus	214	
steering wheel controls	220	
system overview	210	
using a different phone	213	
using your phone	217	
voice mail	214	
Telephone system	210	
Temporary use spare wheel	272	
Tire pressure monitoring system	267	
Tires	256	
damage	264	
glossary	256	
locking nuts	274	
pressures	28	
recommended fitment	266	
renewal	264	
repair	264	
run-flat	273	
snow chains	265	
uniform tire quality grades	277	
wear	263	
wheel changing	275	
winter/snow	265	
Touch-screen	123	
care	123	
display	123	
languages and units	125	
menu structure	127	
Pop-up messages	124	
systems	124	
Timeout to home screen	126	
use	122	
Towing eye	226	
Transmission	157	
Transporting	224	
Trip computer	119	
reset	120	
Type approvals	286	
Using booster cables	243	
Vanity mirrors	141	

Index

Vehicle care	227
aerial	228
alloy wheels	229
automatic car wash	227
bird droppings	229
carpet and mats	230
cloth and fabric	230
convertible top	227
glass surfaces	228
grease and tar	229
high pressure wash	228
leather	229
paint chips	231
underhood	228
washing your vehicle	227
Vehicle recovery	224
VIN	281
Warning lights and indicators	112
Warning triangle	222
Warnings, cautions and notes	30
Warranty	
Mexico	232
USA and Canada	232
Washer fluid check	239
Wheel changing	275
Wheel/tire data	266
Wheels and tires	256
care	256
glossary	278
temporary use spare wheel	272
tire pressures	256
wheel changing	272
Whiplash protection	102
Window tinting	88
Windows	
anti-trap detection	87
operation	86
rear	88
thermal overload	88
Windshield wipers/washers	65
maintenance	66
Winter/snow tires	265